

Conference Notes

29th Annual
Geotechnical Seminar

GEO-Omaha 2012

February 17, 2012
Scott Conference Center
Omaha, Nebraska

Sponsored By:

American Society of Civil Engineers
Nebraska Section

In Cooperation With:

University of Nebraska Department of Civil Engineering
The College of Engineering and Technology

ASCE *American Society
of Civil Engineers*

MORNING SESSION

- 7:30 - 8:00** Registration, Scott Conference Center
- 8:00 - 8:15** **Welcome Address**
Dr. John Rohde
- 8:15 - 9:15** **“Managing Geotechnical Uncertainty into Effective Project Risk Reduction”**
Ray Wood, PE – Fugro Consultants, Inc
- 9:15-10:00** **“Construction and Performance of a Cellular Cofferdam in Northern Ontario”**
Tom Sabourin, PE and John Puls, EI – Kiewit Engineering Company
- 10:00 - 10:30** **Break/Vendor Displays**
- 10:30 - 11:45** **“Optimizing Deep Foundation Design Using Osterberg Cell Static Load Testing”**
Ray Wood, PE – Fugro Consultants, Inc
- 11:45 - 12:45** **Lunch/Vendor Displays**

AFTERNOON SESSION

- 12:45 – 1:30** **“2011 Flood Fight at Eppley Airfield”**
Brian Linnan, PE and Francke Walberg, PE – URS Corporation
- 1:30 - 2:30** **“Landslide Impacts and Repairs in Eastern Ohio Due to Hurricane-Related Storms”**
Jim Sheahan, PE – HDR Engineering, Inc
- 2:30 - 3:00** **Break/Vendor Displays**
- 3:00 - 3:45** **“When Retaining Walls Fail: The Lessons Learned”**
Steve Wendland, PE – Kleinfelder
- 3:45 - 4:30** **“Design Challenges of I-80 Soil Nail Wall”**
Lok Sharma, PE and Ed Prost, PE – Terracon Consultants

Note: In the interest of natural resource conservation, a full copy of the slides and papers provided by our speakers is not provided here, but can be downloaded from the ASCE Nebraska Website: www.neasce.org

Please take time to visit our vendor displays.

- ◆ **ASP Enterprises**
- ◆ **Berkel&Company***
- ◆ **Carmeuse Lime Company**
- ◆ **Foundation Testing and Consulting ***
- ◆ **Fugro Consultants**
- ◆ **Ground Improvement Engineering***
- ◆ **GSI* (Break sponsor only)**
- ◆ **Geotechnology**
- ◆ **Hayward Baker**
- ◆ **HDR Engineering, Inc.* (Break sponsor only)**
- ◆ **Helitech CCD**
- ◆ **Huesker**
- ◆ **Humboldt***
- ◆ **ISG* (Break sponsor only)**
- ◆ **The Judy Company**
- ◆ **KC Piermasters***
- ◆ **Kleinfelder * (Break sponsor only)**
- ◆ **L.B. Foster***
- ◆ **Olsson Associates* (Break sponsor only)**
- ◆ **Propex/Lumbermen's***
- ◆ **Structural Anchor Supply**
- ◆ **Subsurface Constructors***
- ◆ **Tensar***
- ◆ **Terracon* (Break sponsor only)**
- ◆ **The Schemmer Associates***
- ◆ **Thiele Geotech* (Break sponsor only)**
- ◆ **Thrasher Basement Systems***
- ◆ **Uretek***
- ◆ **Workman Precast**

*** - Special Thanks to our Conference Break Sponsors!**



**29th ANNUAL
GEOTECHNICAL
SEMINAR**

February 17, 2012

**Scott Conference
Center**

John Rohde, PhD, PE



UNIVERSITY OF NEBRASKA-LINCOLN

THANKS to the Planning Committee

BRIAN HAVENS, PE; (CHAIRMAN); KLEINFELDER

BILL ARNESON, PE; CONSULTING ENGINEER

LORAS KLOSTERMANN, PE; THE SCHEMMER ASSOCIATES, INC.

BRYAN KUMM, PE; HDR ENGINEERING, INC.

JOHN CHRISTIANSEN, PE; HDR ENGINEERING, INC.

DEANNA BAKER, EI; GROUND IMPROVEMENT ENGINEERING

ED PROST, PE; TERRACON

STEVE SAYE, PE; KIEWIT ENGINEERING COMPANY

ED SCHNACKENBERG, PE; OLSSON ASSOCIATES, INC.

TOM STRAUSS, PE; ISG & ASSOCIATES

JOHN PULS, EI; KIEWIT ENGINEERING

JOHN ROHDE, PhD, PE; UNIVERSITY OF NEBRASKA

NICK WOLFF, PE, LEED AP; GSI

STEPHEN MATYCHUK, EI; THIELE GEOTECH



Geotech @ the U

- THANKS to Steve
- Academic Year '11 – '12
 - Soil Mechanics
 - 93 CIVE
 - 30 AE and CONE
 - Foundations
 - 60 CIVE
 - 12 AE



Curriculum

- CIVE 334 – Soil Mechanics
 - No Great Surprises
- CIVE 436/836 – Foundation Engineering
 - In Situ Testing
 - Report Writing



Plea for Assistance

- Soil Mechanics (Soil to make life interesting)
 - Proctor
 - Atterberg Limits
 - Consolidation



Plea for Assistance II

- Foundations
 - Interesting Data
 - Douglas County
 - In Situ Testing and Sites w/extensive testing
 - Chris Chikos – Wants to Graduate





UNIVERSITY OF
Nebraska.
Lincoln

GEO-OMAHA 2012 PLANNING COMMITTEE

BRIAN HAVENS, PE (CHAIRMAN)
KLEINFELDER

BILL ARNESON, PE
CONSULTING ENGINEER

LORAS KLOSTERMANN, PE
THE SCHEMMER ASSOCIATES, INC.

BRYAN KUMM, PE AND JOHN CHRISTIANSEN, PE
HDR ENGINEERING, INC.

DEANNA BAKER, EI
GROUND IMPROVEMENT ENGINEERING

ED PROST, PE
TERRACON

STEVE SAYE, PE AND JOHN PULS, EI
KIEWIT ENGINEERING COMPANY

ED SCHNACKENBERG, PE
OLSSON ASSOCIATES, INC.

TOM STRAUSS, PE
ISG & ASSOCIATES

JOHN ROHDE, PhD, PE
UNIVERSITY OF NEBRASKA DEPT OF CIVIL ENG

NICK WOLFF, PE, LEED AP
GSI

STEPHEN MATYCHUK, EI
THIELE GEOTECH

“Managing Geotechnical Uncertainty Into Effective Project Risk Reduction”

“Optimizing Deep Foundation Design Using Osterberg Cell Static Load Testing”

Ray Wood, PE

Fugro Consultants, Inc
Executive Vice President

Mr Wood graduated from the University of Cambridge with a Master of Arts in Engineering specializing in Soil Mechanics, Geotechnical Engineering and Materials Science. He was awarded an MBA from Henley, the Management College. He is a Chartered Engineer in the United Kingdom and a Member of the Institution of Civil Engineers.

With a career spanning more than 32 years with the Fugro Group of Companies in South East Asia, the Middle East, Europe, and the United States, Mr. Wood has a wealth of experience in deep water, coastal and land site investigation and foundation design, in situ testing, engineering geophysics, geo-monitoring, and deep foundation testing. He has managed Fugro Operating Companies in Hong Kong, the United Kingdom and North America. He has been a guest lecturer at several universities and is a recognized specialist in deep foundation design, testing and optimization. Serving as Executive Vice President of Fugro Consultants with responsibility for their Atlantic Region, Mr. Wood is also a Director providing management supervision to a number of Fugro Operating Companies around the world.

His professional interests are business risk management, innovation in geotechnical site characterization and contract law.



Uncertainty and Risk in Geotechnics

- Dealing with Uncertainty
 - Factors of safety (global/partial)
 - Conservatism (lower bound design profiles)
 - Antiquated building codes

$$E=MC^3$$

E: Engineering

M: Mediocrity

C: Conservatism, Complacency and Codes (after J Hayes)

- Reducing uncertainty automatically leads to improved risk management
- Superior management of risk drives superior (super normal) business performance

Effects of Uncertainty

Public Safety

- Collapse – injury death and property damage
- Public confidence in engineering undermined

Economic

- Replacement work and sometimes project cancellation
- Unforeseen (rather than unforeseeable) ground conditions often lead to claims
- Delays to project delivery
- Uncertainty often leads to additional conservatism increasing the foundation cost

How many foundation designers seek and receive feedback on the cost of their design?

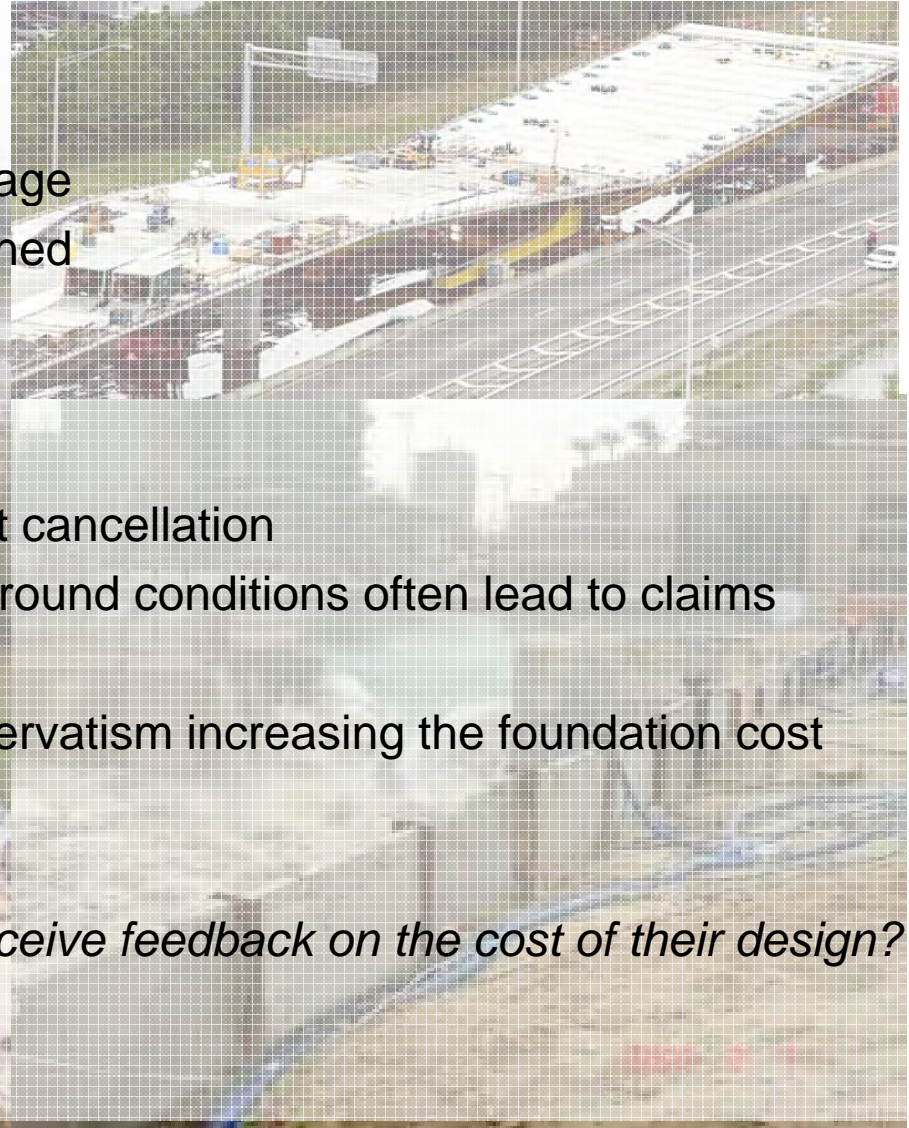



Uncertainty in Geotechnical Engineering

Three broad sources:

- Site Variability and Conformance Errors
 - Phased integrated investigations incorporating:
 - Desk Study/Remote Sensing
 - Geophysics – overall geological structure and targeting of intrusive work
 - In-Situ Probing – continuous vertical profiling and targeting sampling
 - Borehole Drilling and Sampling – improved technique, better lab testing
- Design Method Applicability
 - Code values, resistance factors/FoS, coefficients
 - Site specific verification, calibration and optimisation
 - Full or Semi Full Scale Testing
- Construction Quality
 - Experienced supervision
 - Effective foundation acceptance criteria
 - QC testing

“much of a civil engineering project’s risk lies in the ground”



Integrated Ground Investigations

- A staged approach using progressively more targeted techniques to develop a project ground model
- Significant advances in geophysical techniques provide effective tools for obtaining an overview of geological conditions before intrusive investigation
- Intrusive investigation carefully targeted to calibrate geophysical information and further investigate and describe strata of engineering significance
- Continuous in-situ profiling (eg CPT) often identifies significant layers missed by traditional drilling and sampling programmes
- Combined use of in-situ testing (CPT/DMT) reduces uncertainties associated with sampling disturbance and laboratory testing
- Knowledge of soil conditions in advance of drilling and sampling leads to better samples and borehole logs
- Significantly more information does not have to cost more and often can cost less
- Semi full scale or full scale tests should always be considered to calibrate design methods for a site

The Exploration Parallel

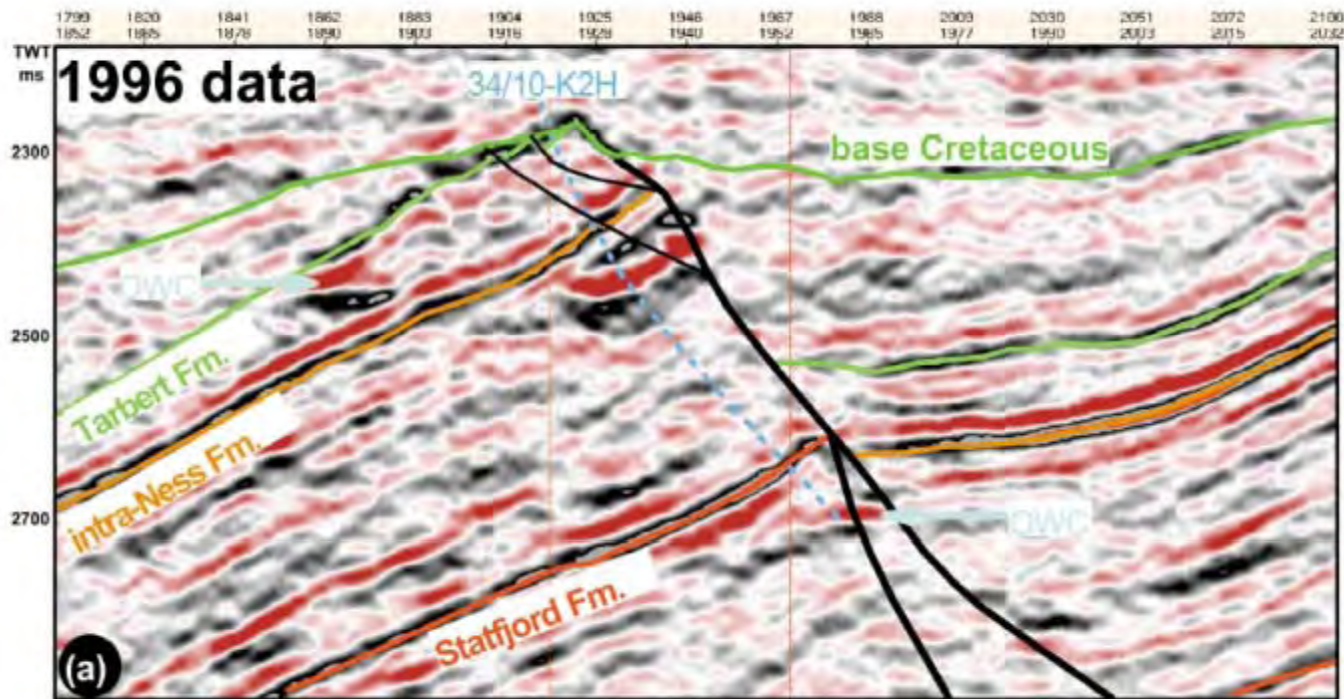

- shelf drilling \$10-30M per BH
- deep water \$80-100M+ per BH

Impact of Site Investigation On Overrun

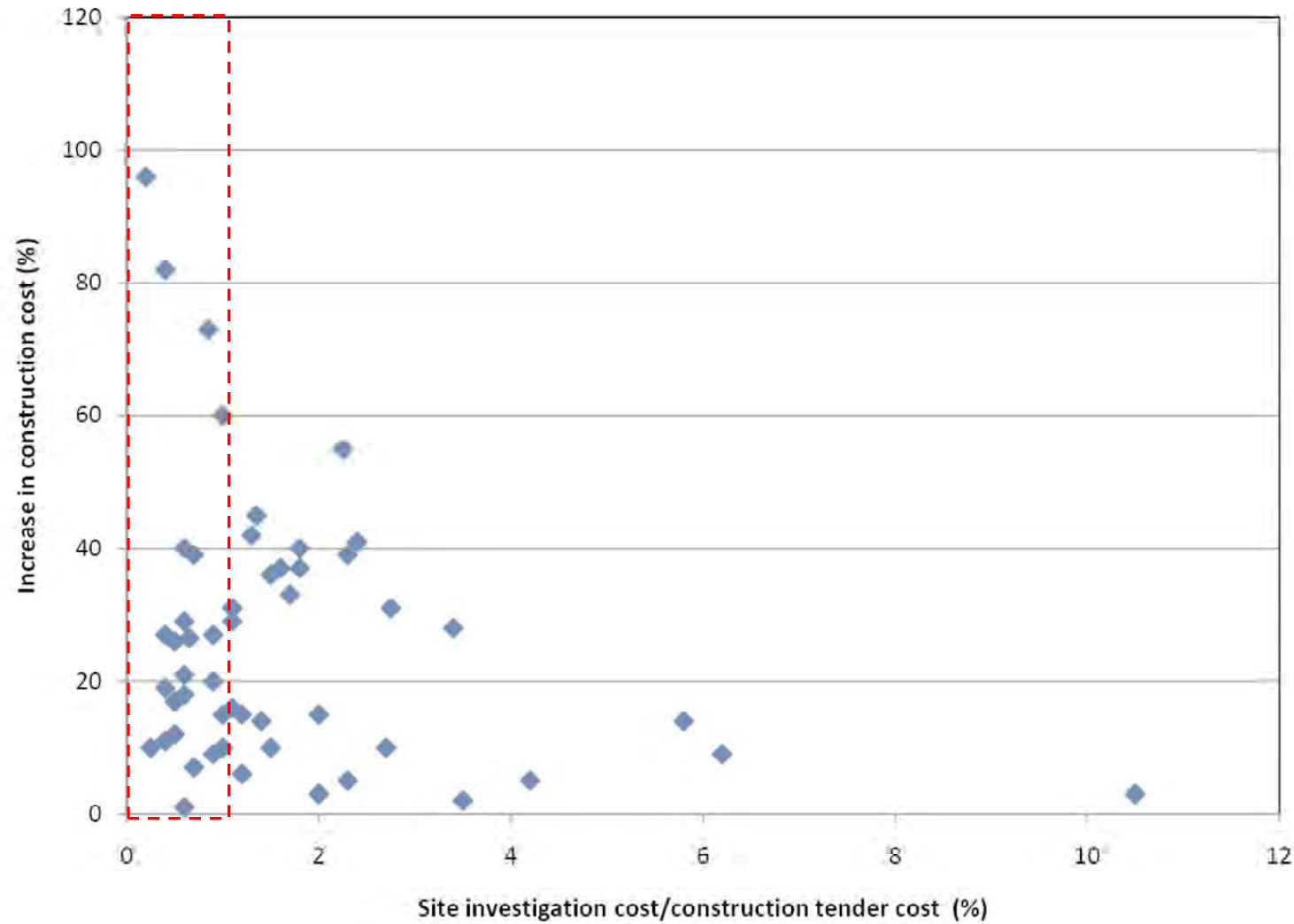

Impact of Site Investigation on highway contract cost over-runs in the UK from TRL Project Report 60

Capturing Experience

Geotechnical problems during construction

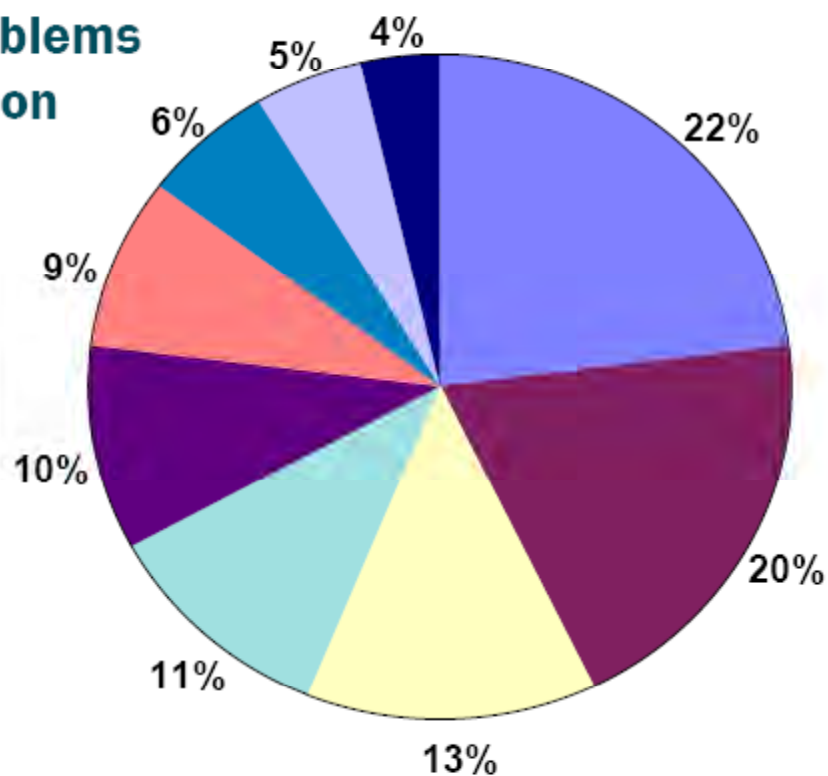

From a survey of 28 construction projects (Clayton, 2001)



Intrusive Investigations

- **derive key ground data**

**geological
geotechnical
hydrogeological**

- **are they spatially representative?**
- **are they optimally planned both in distribution, sampling interval and depth?**
- **too many?**
- **too few?**



Geophysical Investigations

- **derive key ground data**

**geological
geotechnical
hydrogeological**

- **are commonly an integral element of SI?**
- **are well understood?**
- **are appropriately deployed?**
- **are optimally scheduled/phased to help manage risk?**
- **are used to minimise client outturn cost?**

SURFICIAL GEOLOGY

Using detailed satellite data to map alluvial and colluvial deposits in detail down to 1:10,000 scale, with interpretation of aerial photography allowing for 1:5,000 scale mapping of geomorphic landforms and surficial deposits, integrated with detailed DEM data.

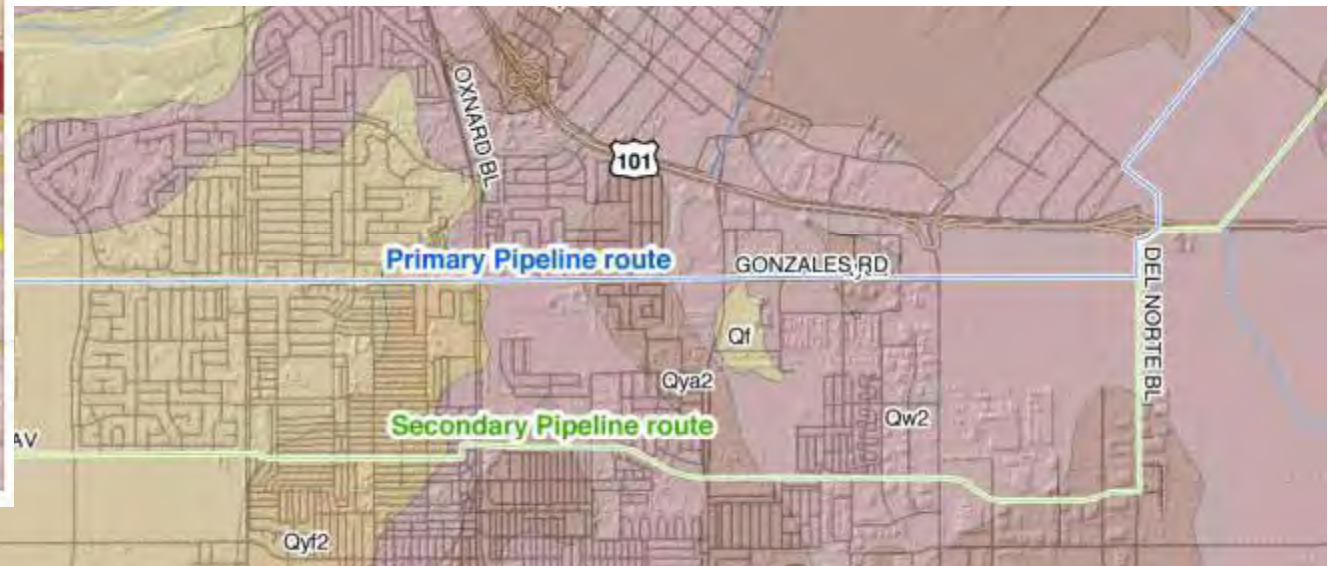
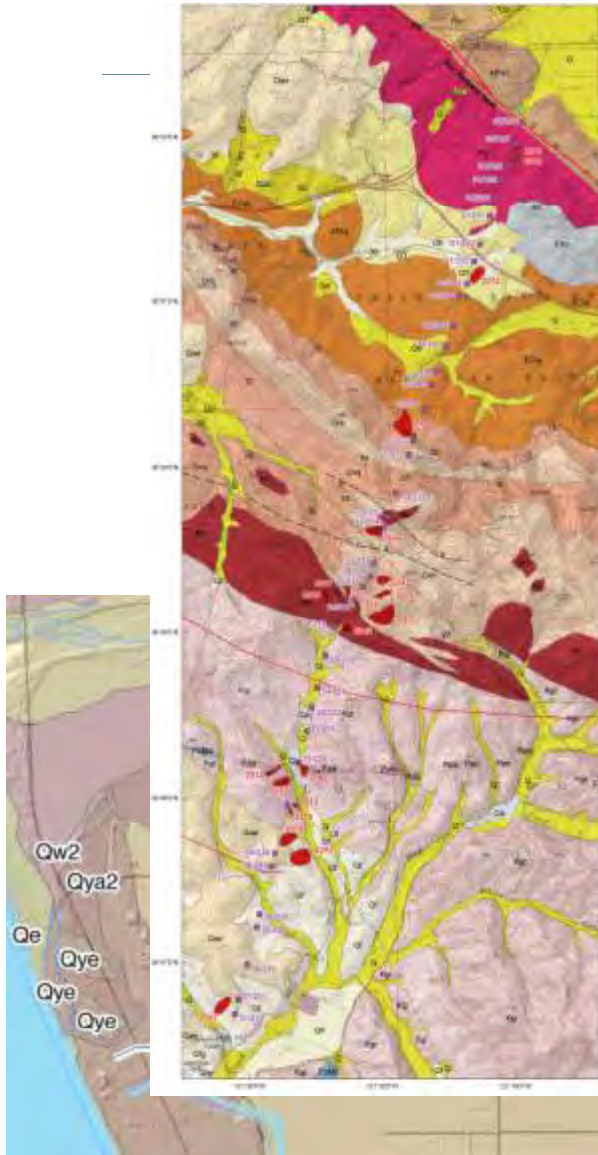

Mining subsidence

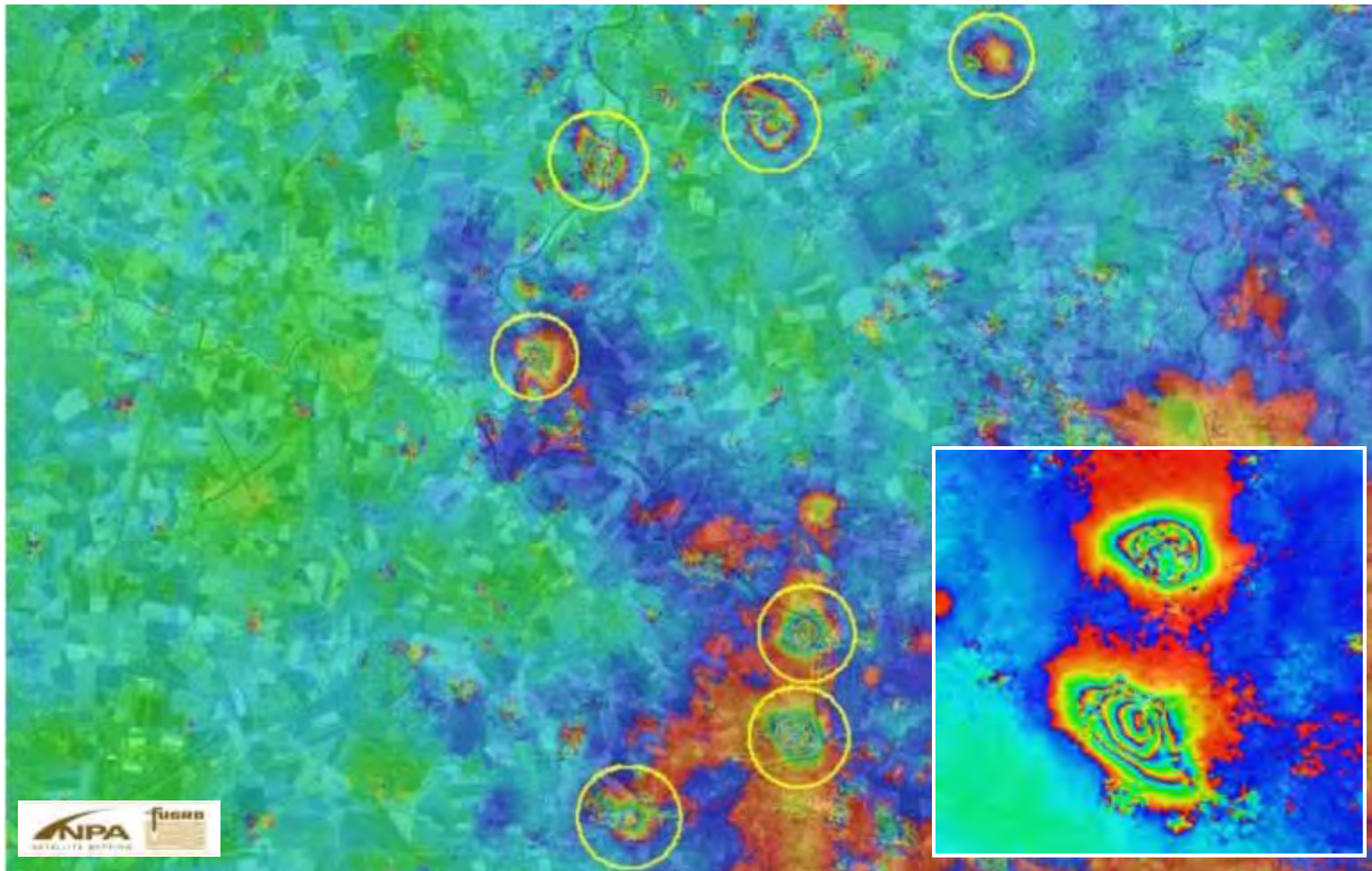

Formation of surface subsidence bowls (motion contours / interferometric fringes) correlated to underground coal mining activity over a 35 day period detected and mapped through DifSAR. Up to 15 centimetres of surface subsidence recorded.

Long term monitoring - Sacramento

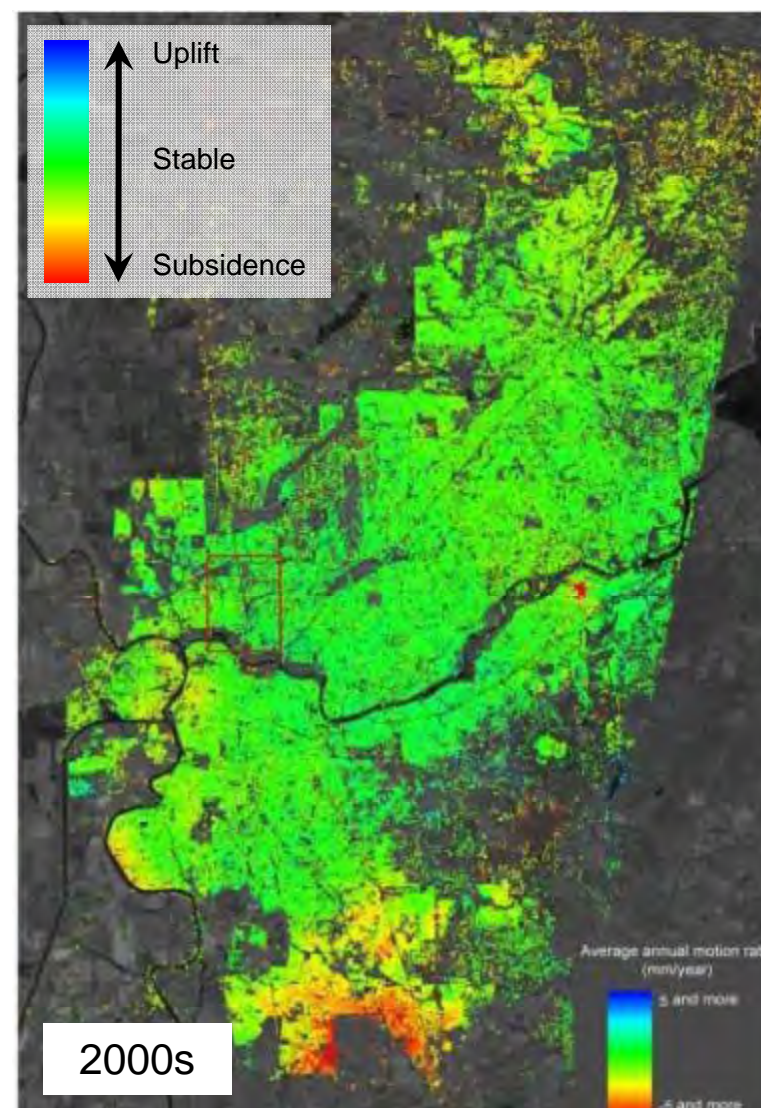
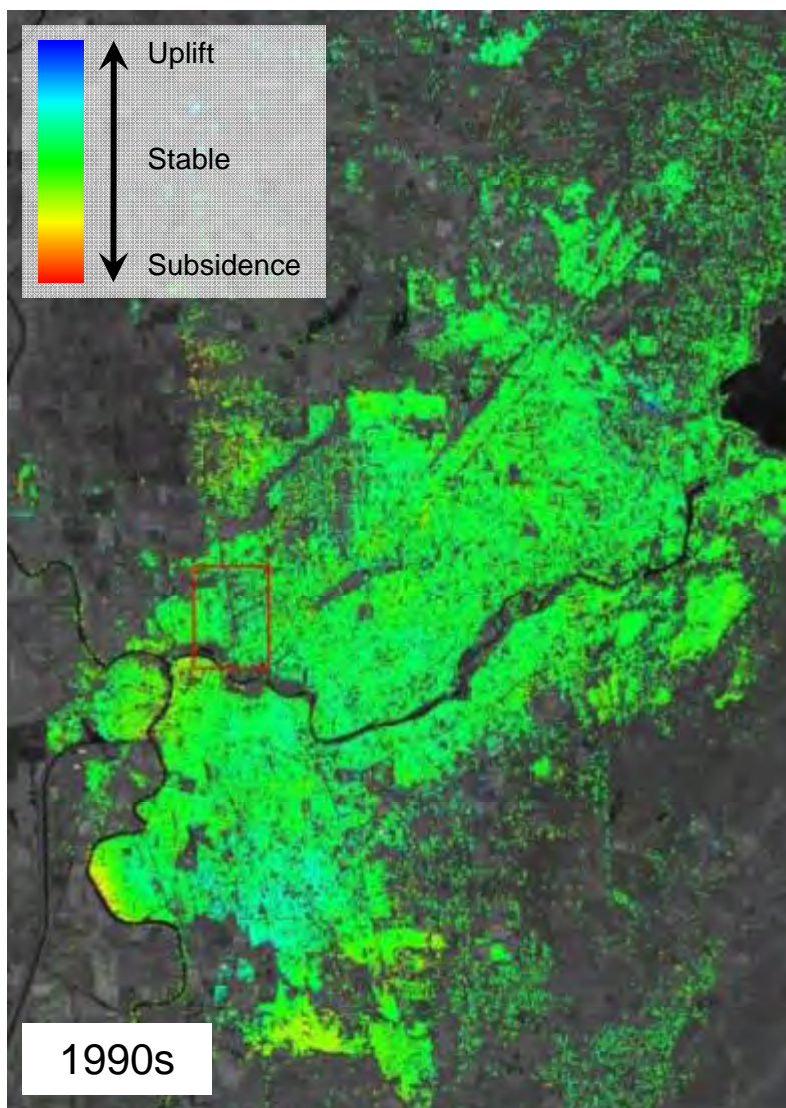



Engineering Geophysics

Black art of the mystic or reliable site characterisation tool?

- Equipment and data processing techniques have developed enormously over the last decade
- The engineering sector has benefitted significantly from investments and advances in signal processing from the offshore Oil & Gas exploration industry
- Has suffered in the past from overselling
- When delivered by skilled and experienced practitioners with appropriate techniques for the particular site provides a very effective tool for targeting subsequent intrusive investigations to build a calibrated 3D ground model

'One thing is certain:

The need to better characterise the upper 100 m of the Earth's surface is going to escalate to the point at which geophysical efforts (monetary and manpower) in the near surface will surpass those exerted in the pursuit of petroleum'.

Source: Miller R and Baker G, The Leading Edge February 2011



Geophysical Deliverables

Determination of ground geometry



Imaging

Determination of ground properties



Properties



Geophysical parameters

Imaging

Mass, acoustic impedance, electrical, dielectric, magnetic properties

Properties

Elastic moduli, seismic velocities, density, porosity, resistivity, radioactivity

Geohazard investigation – cavities and karst



Geohazard investigation – cavities and karst

Electromagnetic Conductivity Profile

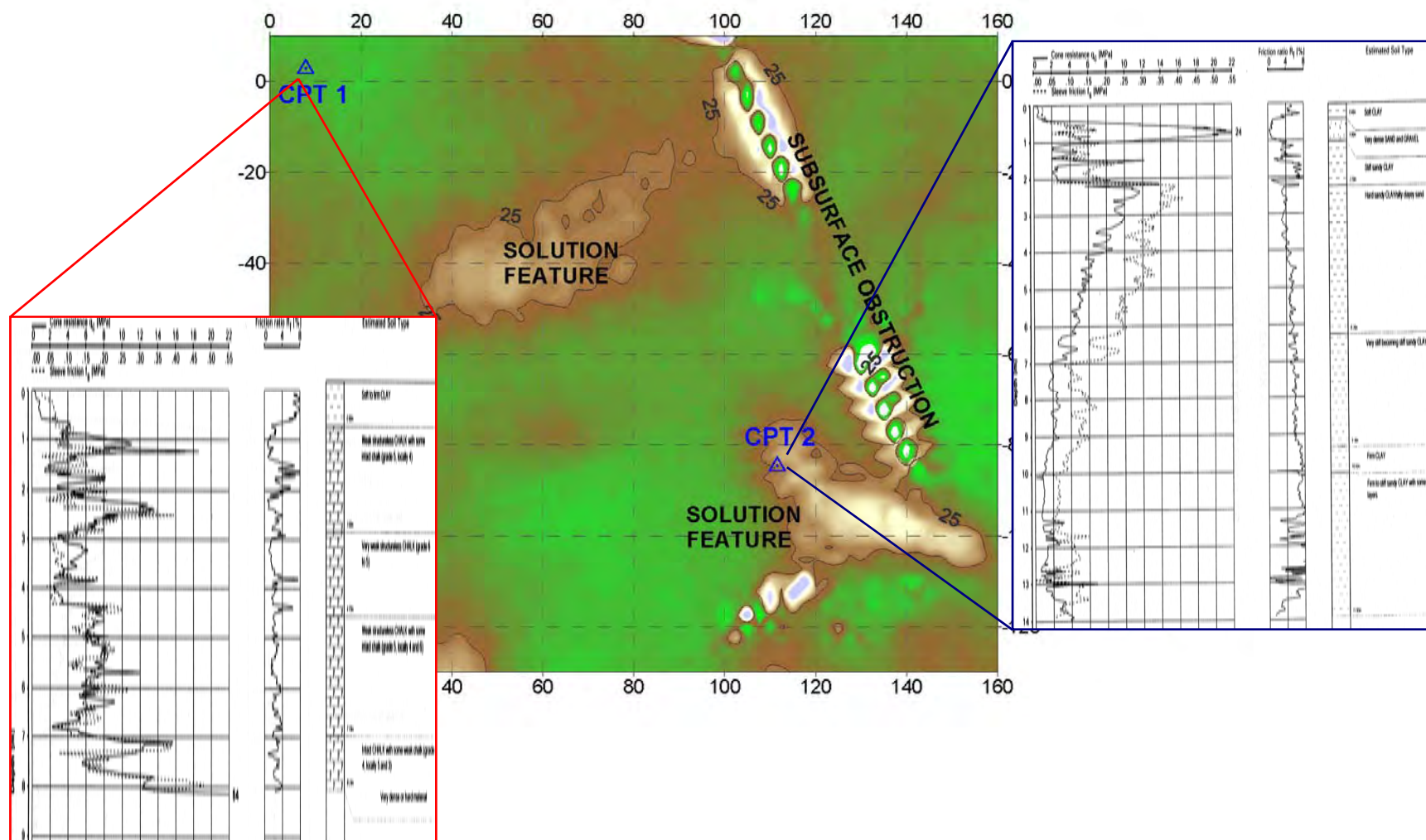

Geohazards – solution features

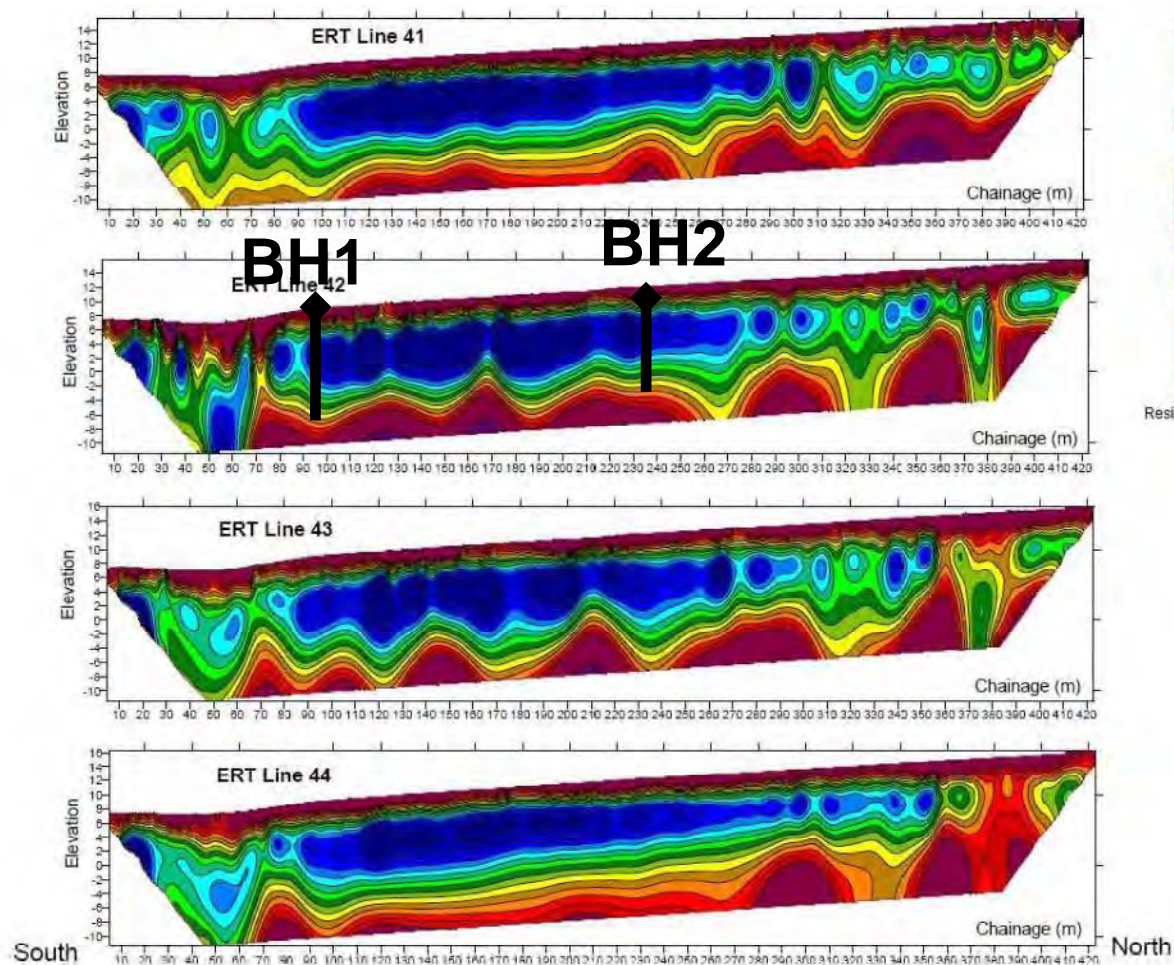

(2D ERT, Quaternary/
Tertiary/Cretaceous)

- Electrical Resistivity Tomography Profiles
- Spatial sampling

Geohazards – Infilled Features

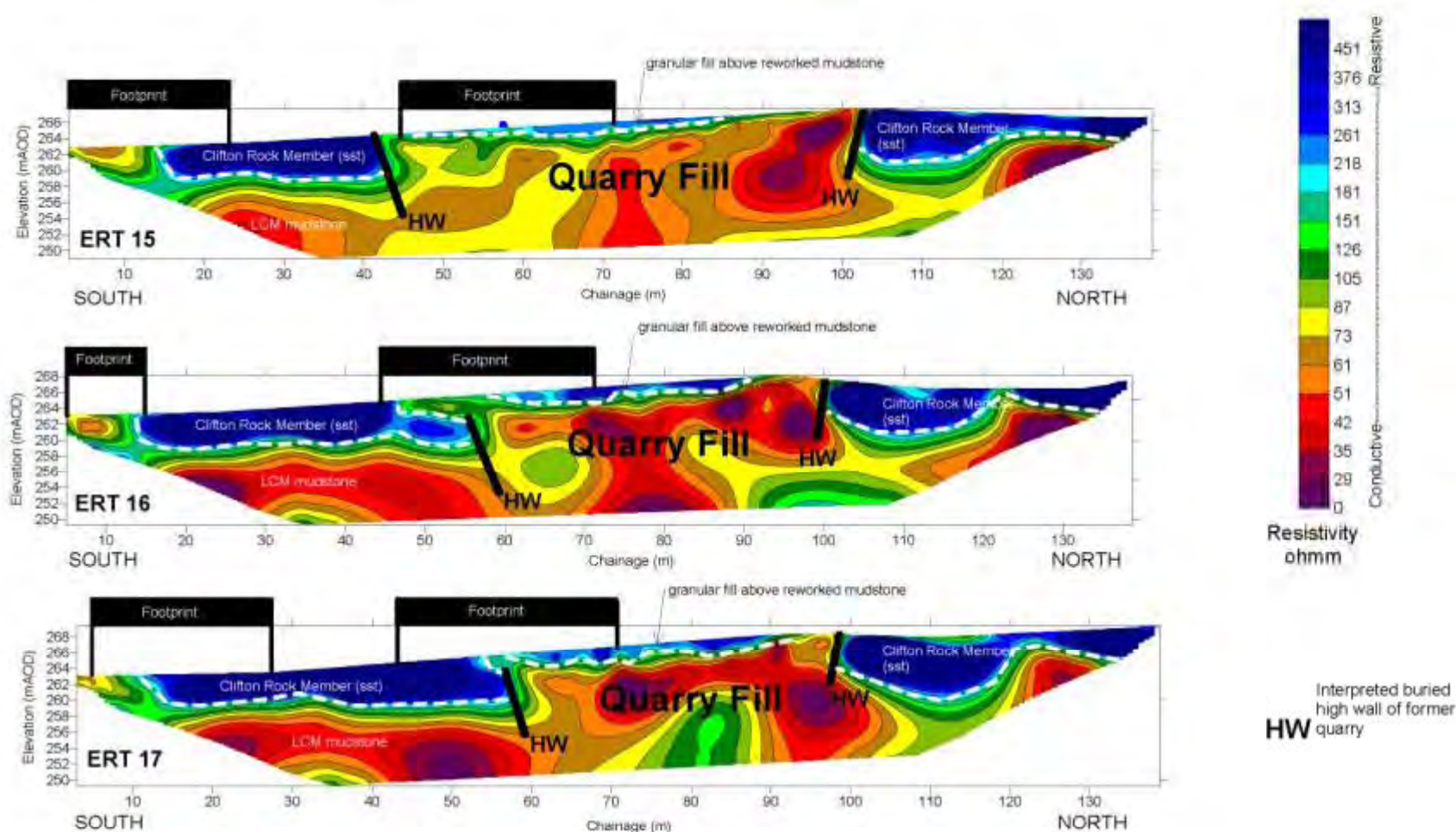

Geohazards – Infilled Features



Pipeline Stationing

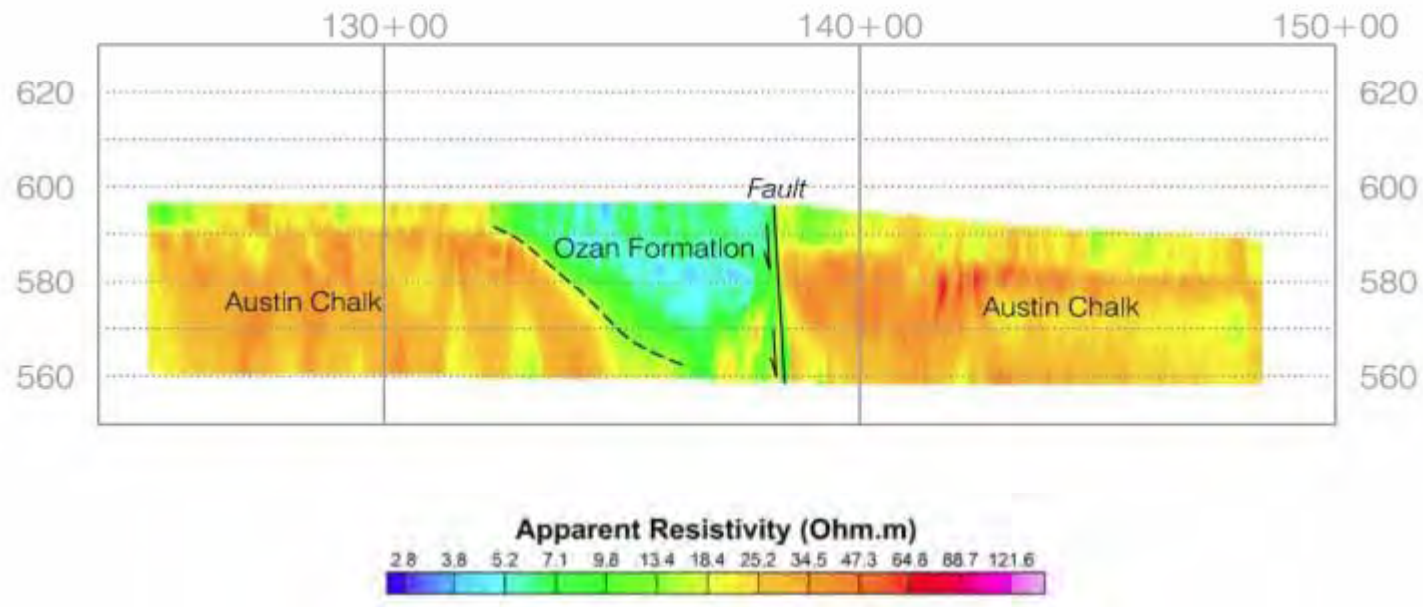

- 147 mile long pipeline route – 10 foot diameter, with 10-15' cover
- Boreholes planned at 1,000-2,000' spacing
- Significant features less than 1000' long that could have been missed
- Features longer than 8,000' that do not require as many boreholes to characterise
- Perform same number of boreholes but on targeted non-uniform spacing to provide more information, reducing Contractor's pricing risk and Client's cost

Geohazard investigation – fault reactivation



Geohazard investigation – fault reactivation



Geohazard investigation – fault reactivation

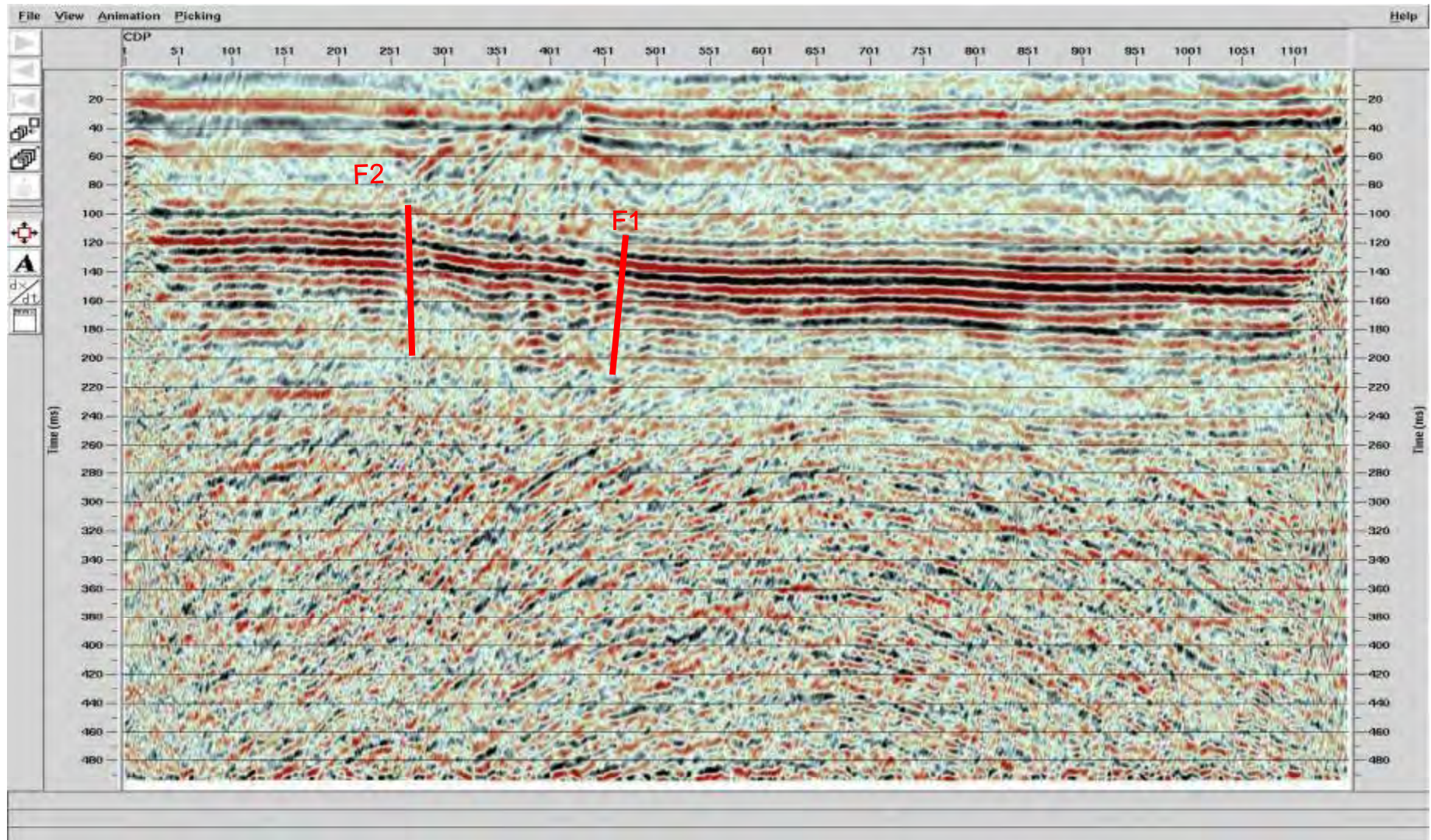

Engineering properties

Significant cavity opens up near to major infrastructure in UAE as a result of heavy rains.

Geology = karstic limestone

Surface cavity thought to be linked to subsurface solution features.



Seismic investigation carried out using MASW

Measurements taken along profile lines over existing hardstanding and unsurfaced areas

Engineering properties

By combining adjacent 1-D profiles together, a 2-D depth cross-section may be derived. Incorporating density information allows for derivation of shear modulus.

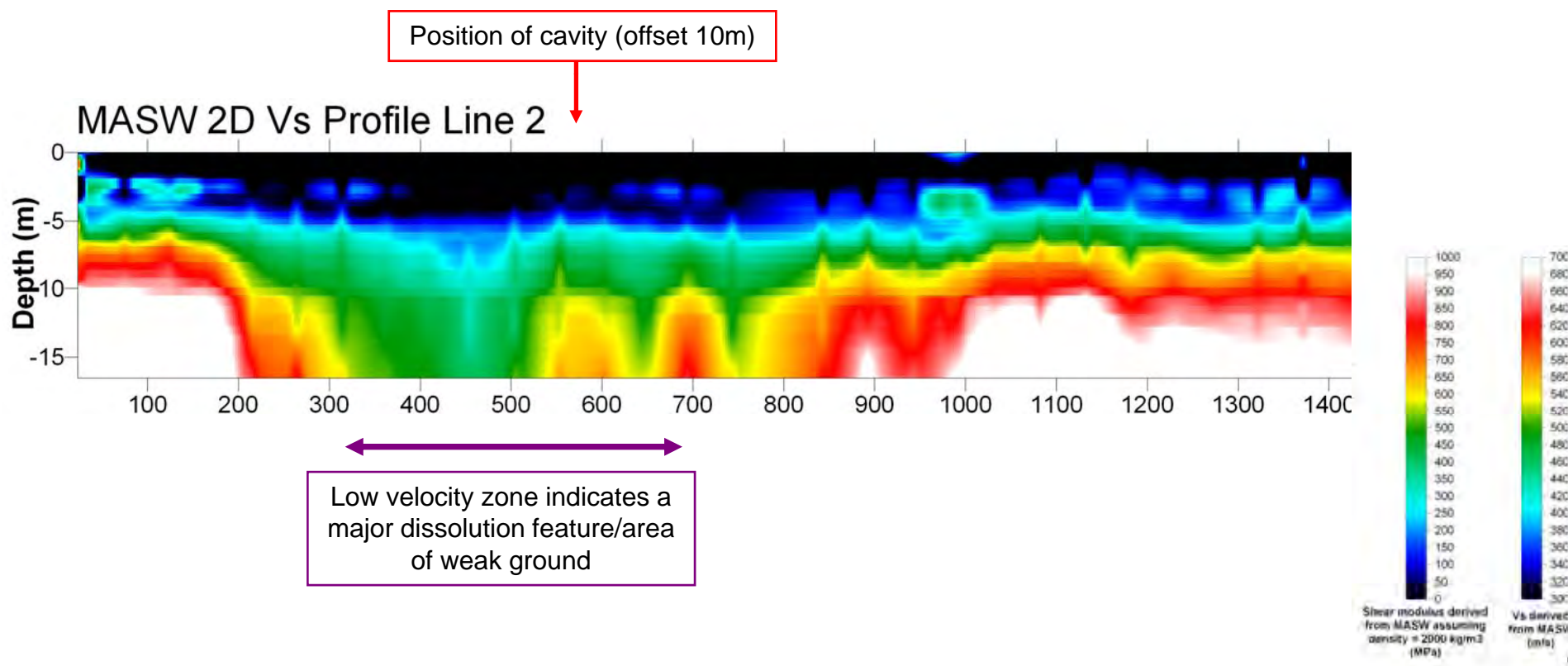



Bedrock Mapping

We use **Seismic Refraction Tomography**:

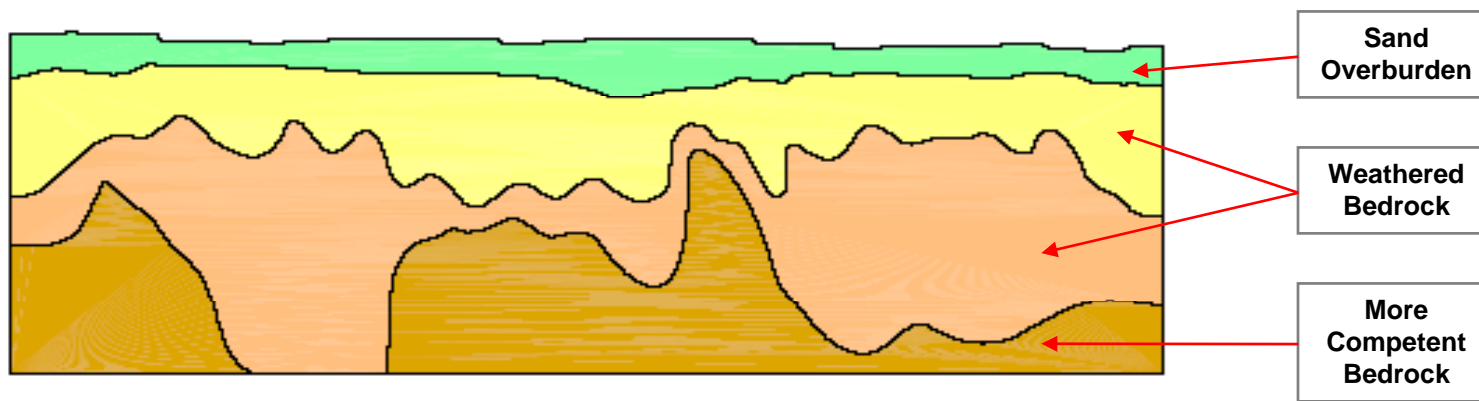
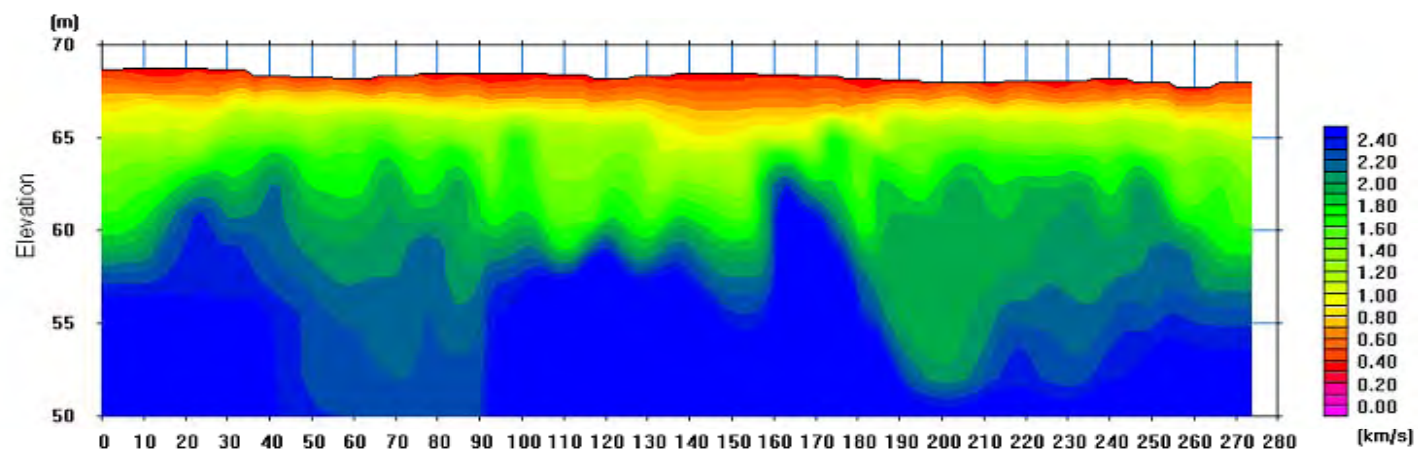



Bedrock Mapping

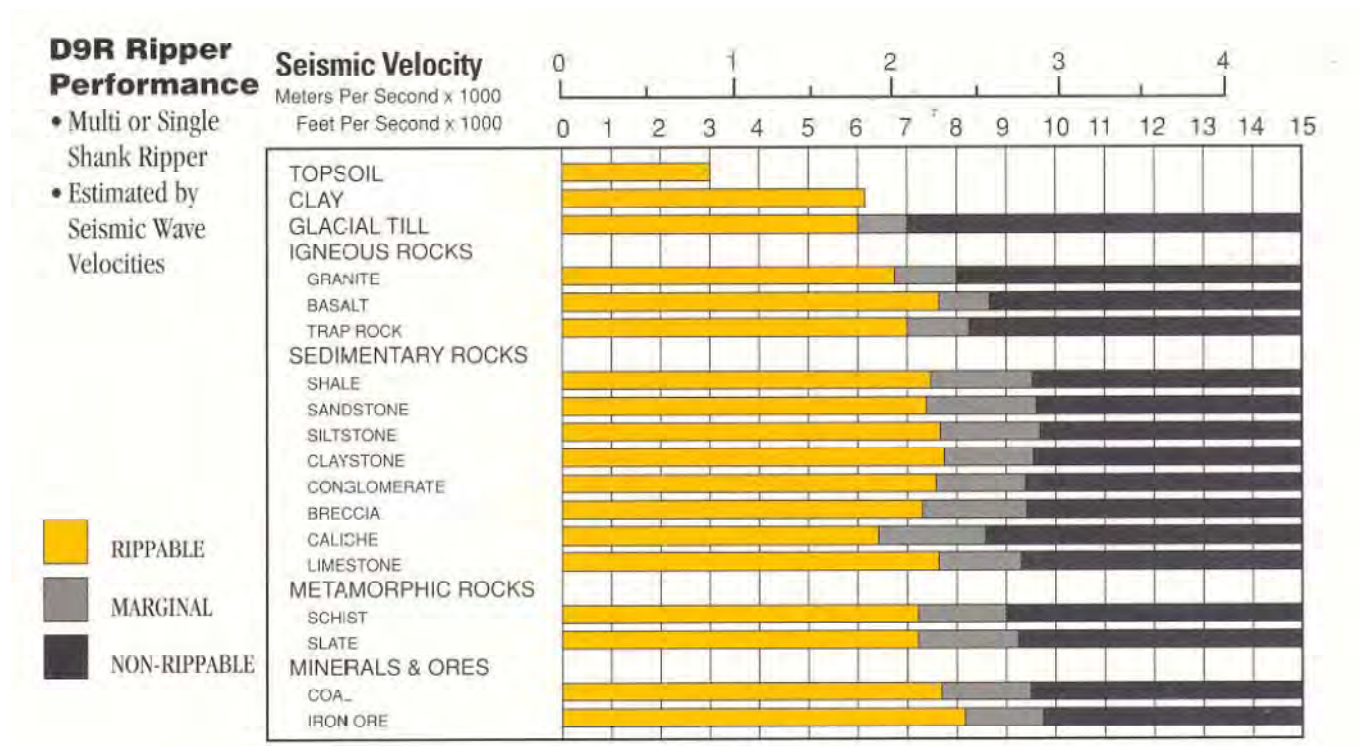

However, we can use more advanced processing techniques to interrogate lateral and vertical variations in stratigraphy.....

Bedrock Mapping

Survey Area

South Soko Island

Proposed LNG installation

Extreme terrain and dense vegetation

Difficult access for personnel and plant

Major ground works (excavation, blasting, slope stability) required as part of installation design

Requirement for assessment of thickness of weathered material/**depth to granite bedrock**

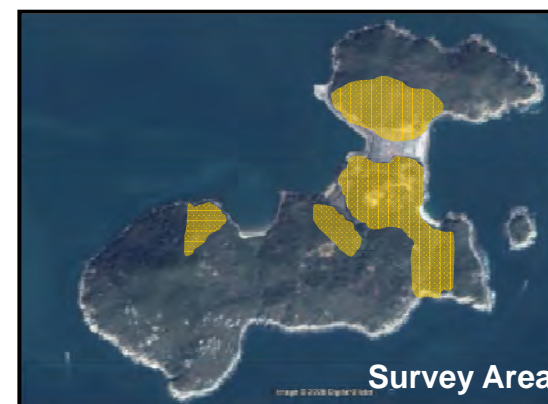
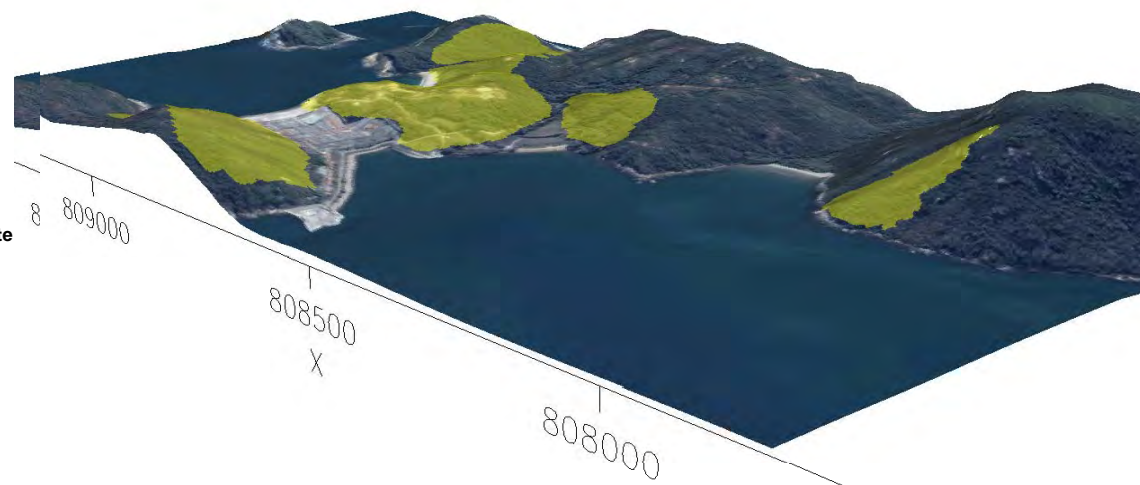

Geophysical survey undertaken over approximately 3 hectares employing **Microgravity** in conjunction with a targeted geotechnical investigation.

An **increase in density** is expected in competent Granite, therefore variations in gravity can be used to profile the Granite surface.

Bedrock Mapping

Microgravity Theory:

The Microgravity technique relies upon the measurement of the Earth's gravitational field.

The Earth's gravity field varies as a result of:

The position of the Sun and Moon

Elevation

Sea level

Terrain

Latitude

Surface features (i.e. buildings etc)

Near Surface Density variations

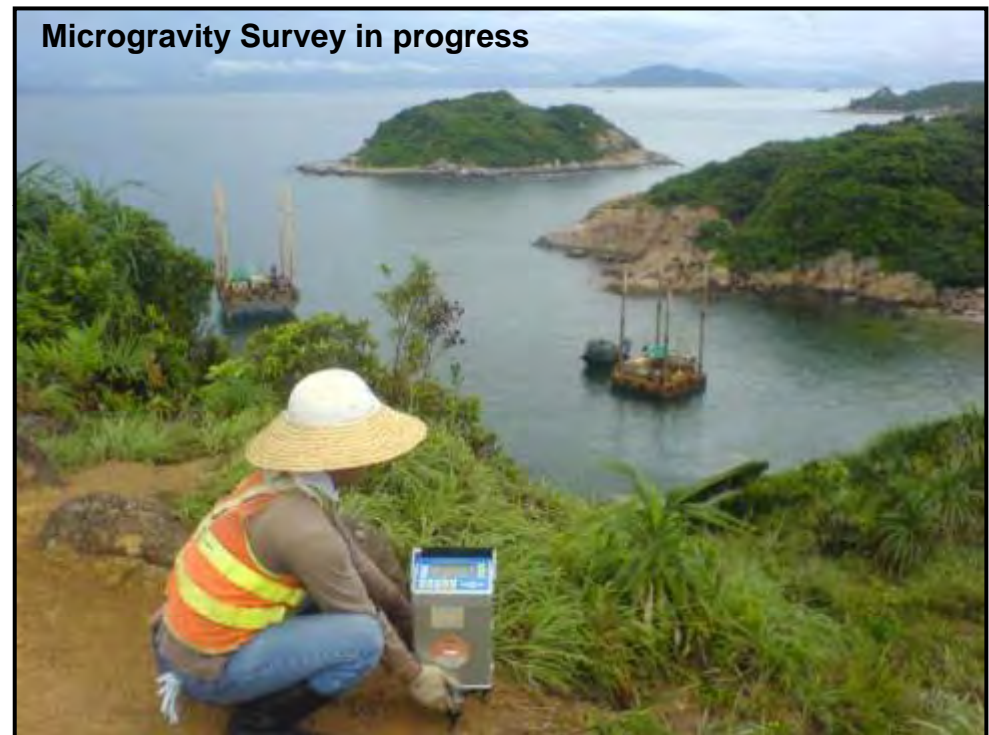

Bedrock Mapping

Mapping cover materials – microgravity example

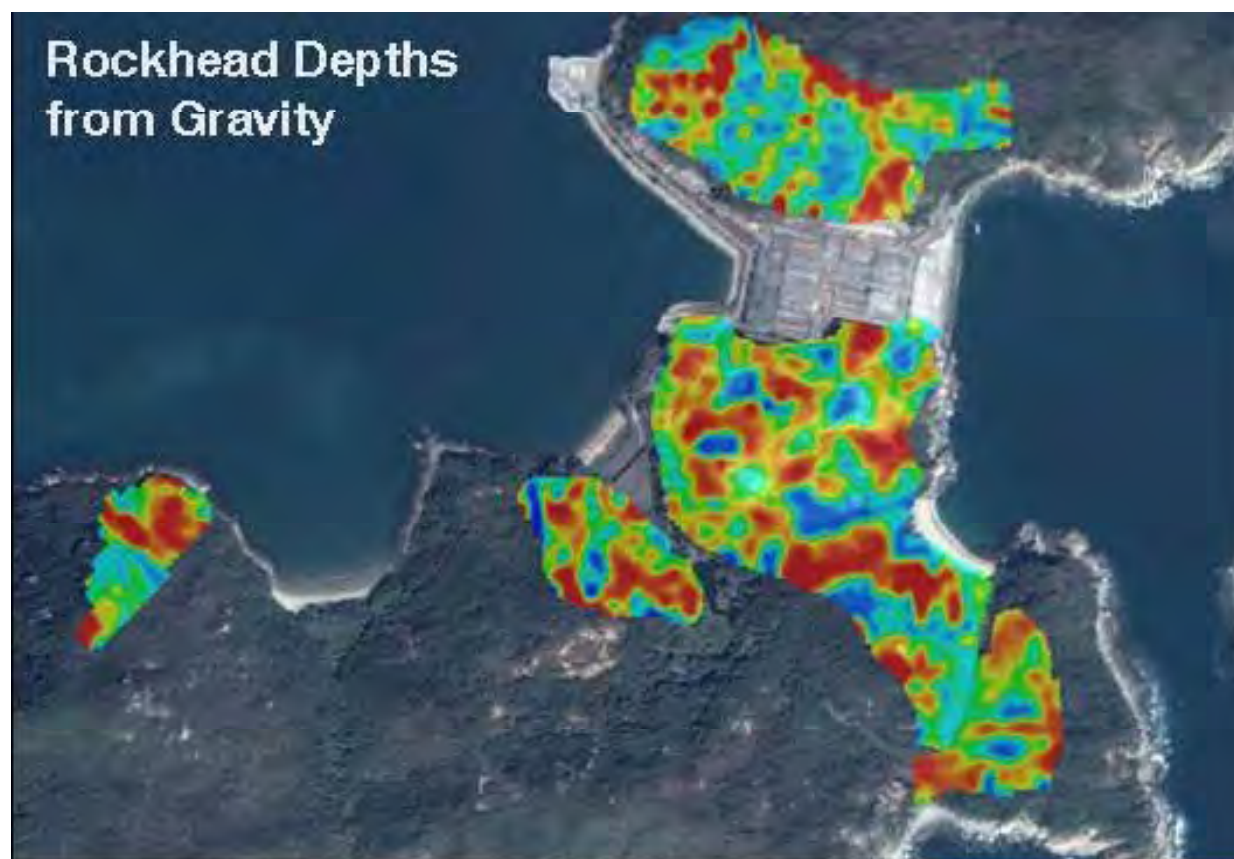

Over 50 onshore drill-holes and trial pits were carried out.

Most locations required helicopter lifts

Rockhead depth map produced from drill holes shows only broad variations

Rockhead depth map produced from both the **microgravity** results and drill holes shows much more variable bedrock profile.

This example highlights the fundamental problem of spatial sampling associated with most intrusive programmes. More detailed information can be obtained by 'filling the gaps' with geophysics*.

Bedrock Mapping

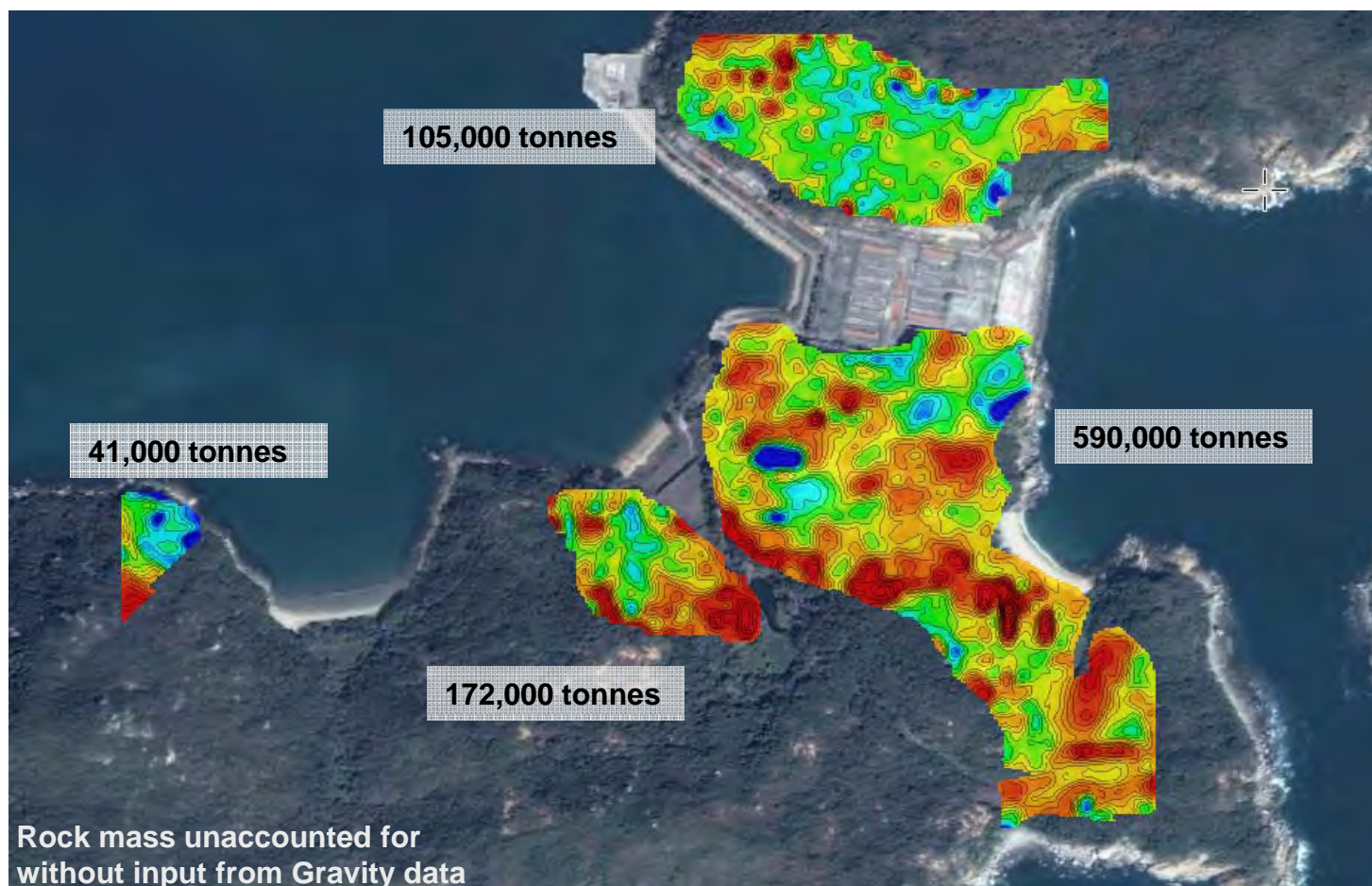



In-Situ Probing

Making measurements of ground type, strength, stiffness and other parameters directly in the ground for use in site characterisation and geotechnical design

Advantages

- less disturbance due to total stress relief, sample handling, transportation and storage
- can provide continuous vertical profile of subsurface information
- Ability to reliably identify thin but significant soil strata
- Repeatability
- Speed (approximately 5x field production of boreholes)
- Unit Cost (approximately 1/3 the cost of boreholes)
- Virtually instant availability of results to allow modification/optimisation of future scope of work

Disadvantages

- Limited penetrability in very strong/dense soils
- Direct design methods need further development
- More correlations with 'Known' geotechnical parameters needed

Electric PiezoCone Penetration Testing

- Hydraulically push an instrumented probe into the ground
- Generally measures end resistance, q_c ; sleeve friction, f_s ; and pore water pressure generated during penetration, u
- Additionally, geophones, temperature, electrical conductivity, pressuremeter
- Generally 10cm^2 (35.6mm dia) or 15cm^2 (43.7mm dia)
- Pushed until refusal
- Deployment systems from Land, Seabed and from Bottom of a borehole
- Inclinator measurements to correct for non vertical penetration
- Data transmission by cable, on board memory or by telemetry
- High resolution A to D means measurement of q_c to less than 5kPa

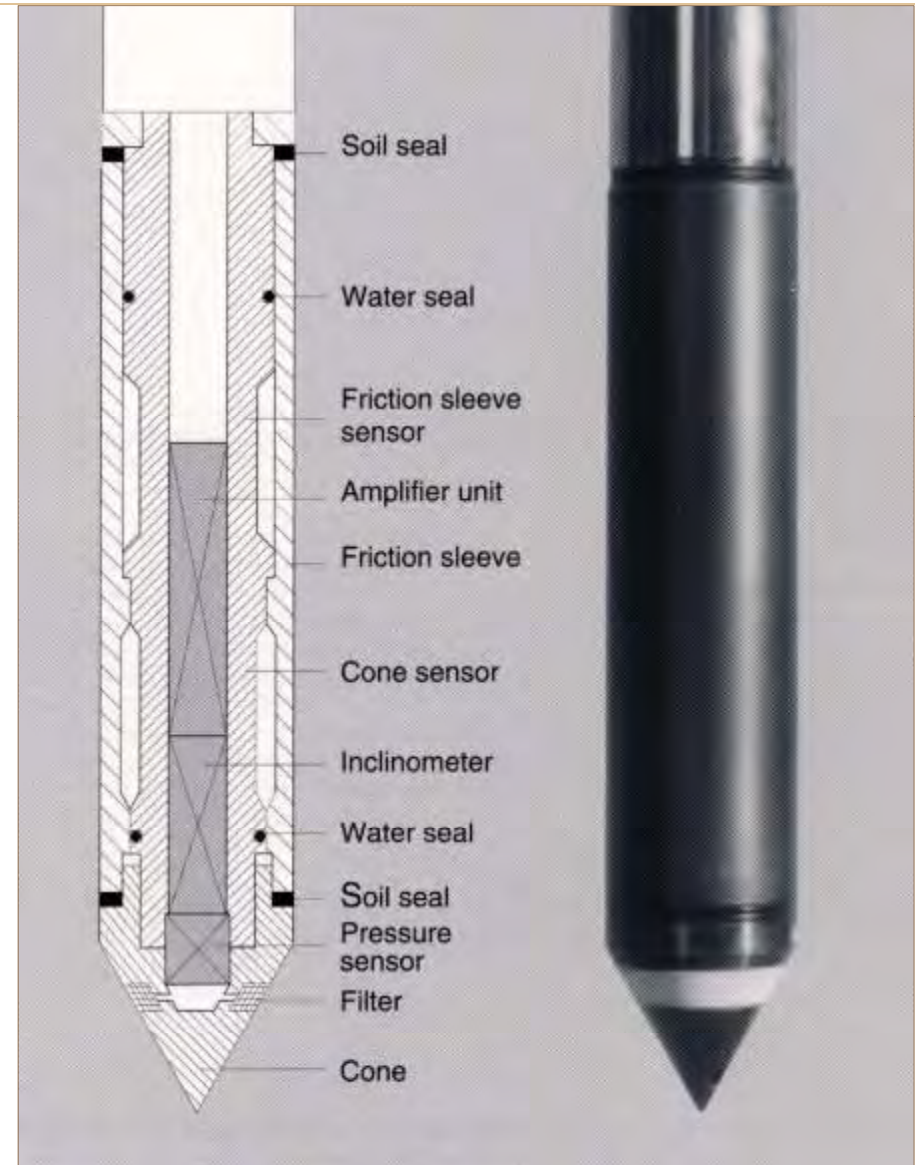

CPT Deployment Systems

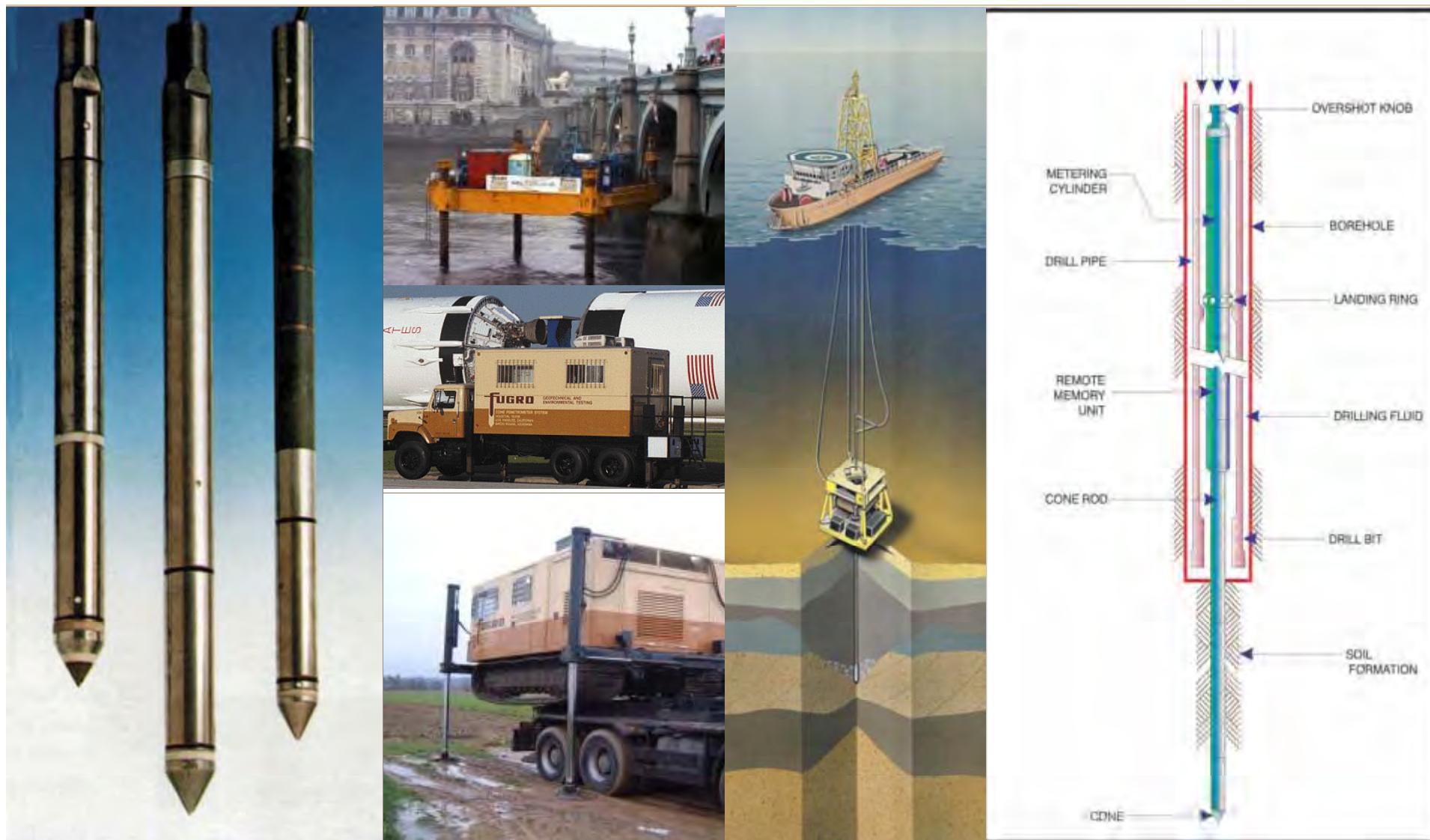

Principle of the Cone Penetration Test

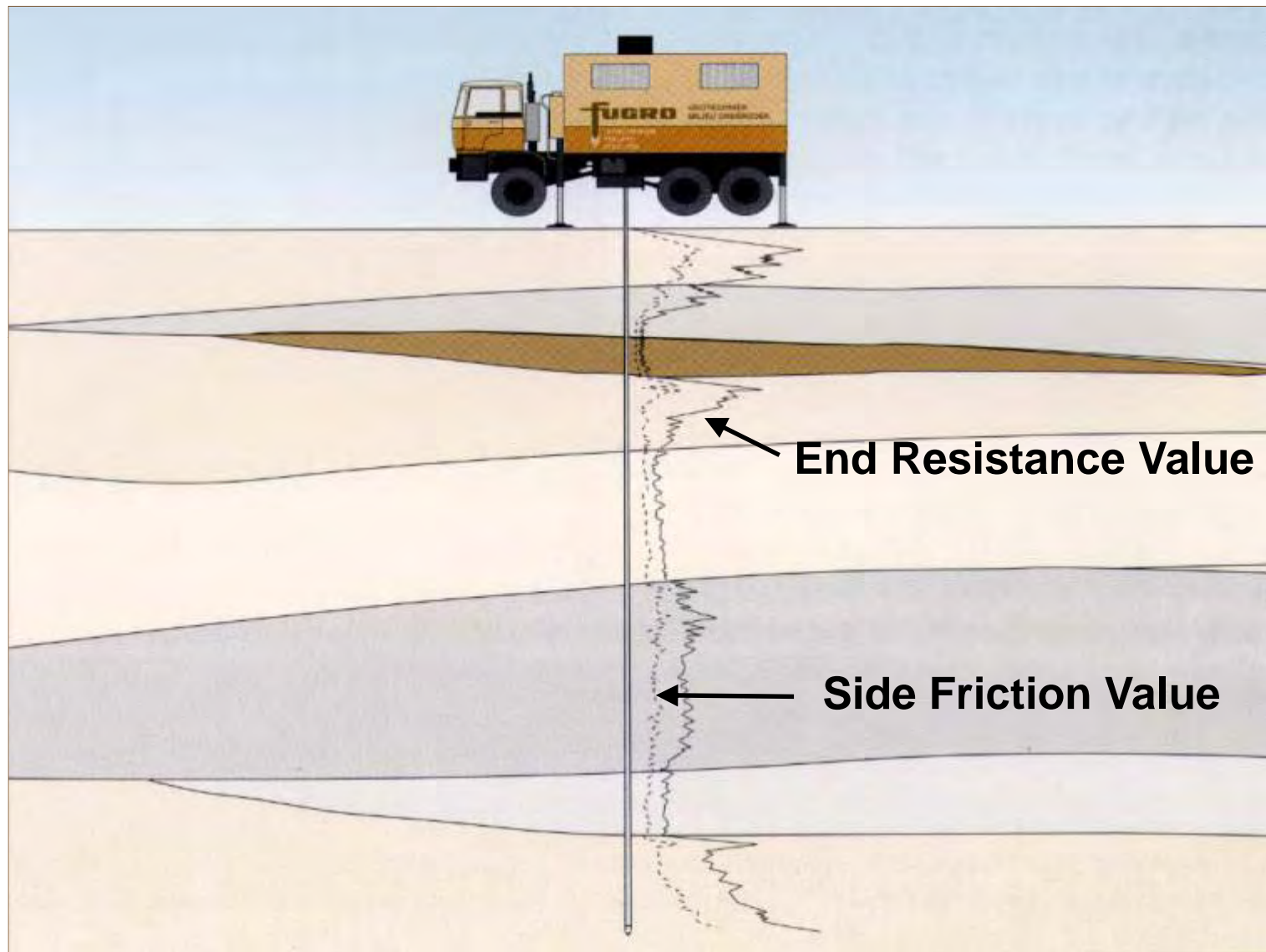

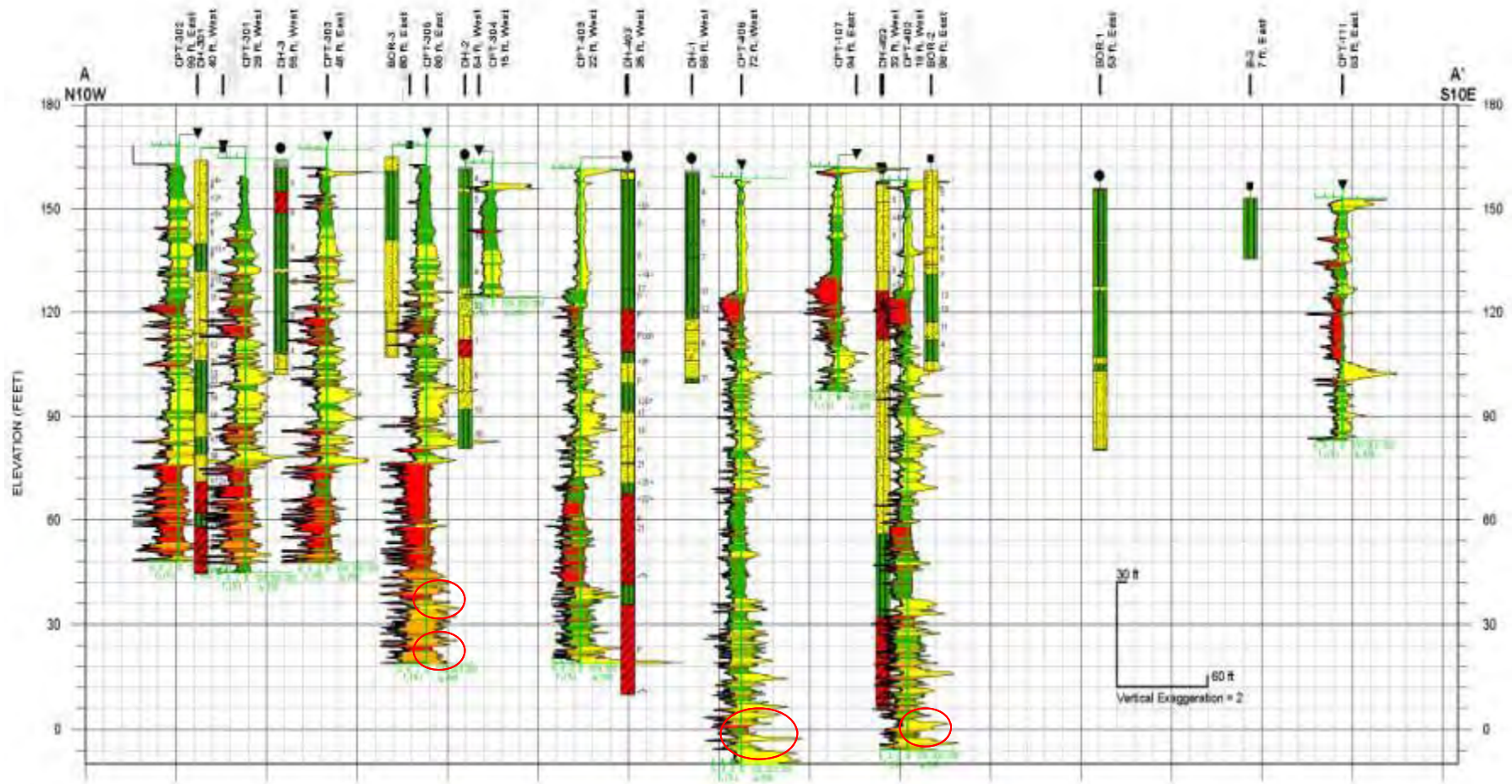

○ Weak areas potentially of concern for end bearing of deep foundations

CPTs - repeatability

- overlay of 5 CPTs
- off scale Q_c at ~13m due to claystones
- the Cone broke through the claystones allowing full penetration

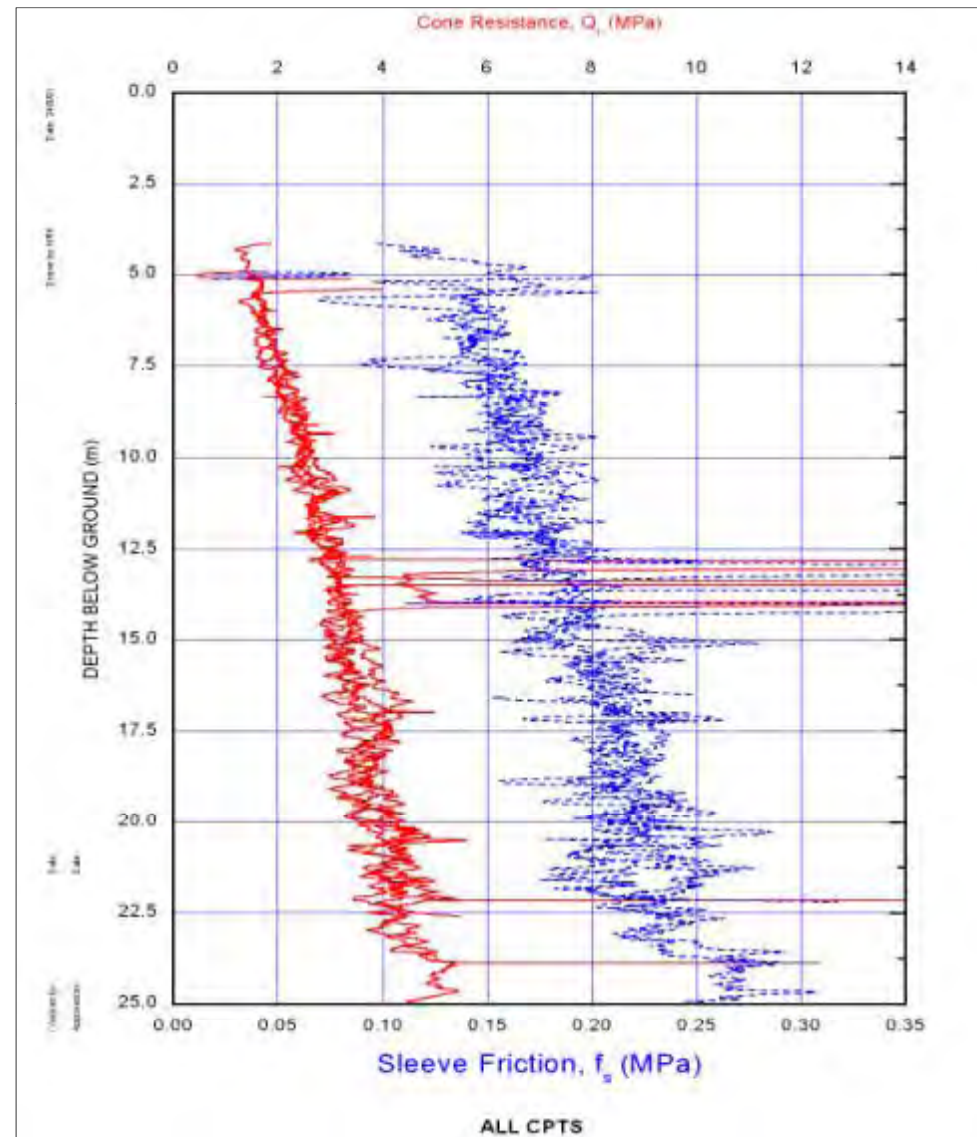

Craney Island Project - Strength Variability

Comparison of Strength Measurements

- In Situ Vane
- Laboratory Triaxial
- Laboratory Vane
- In Situ T-bar

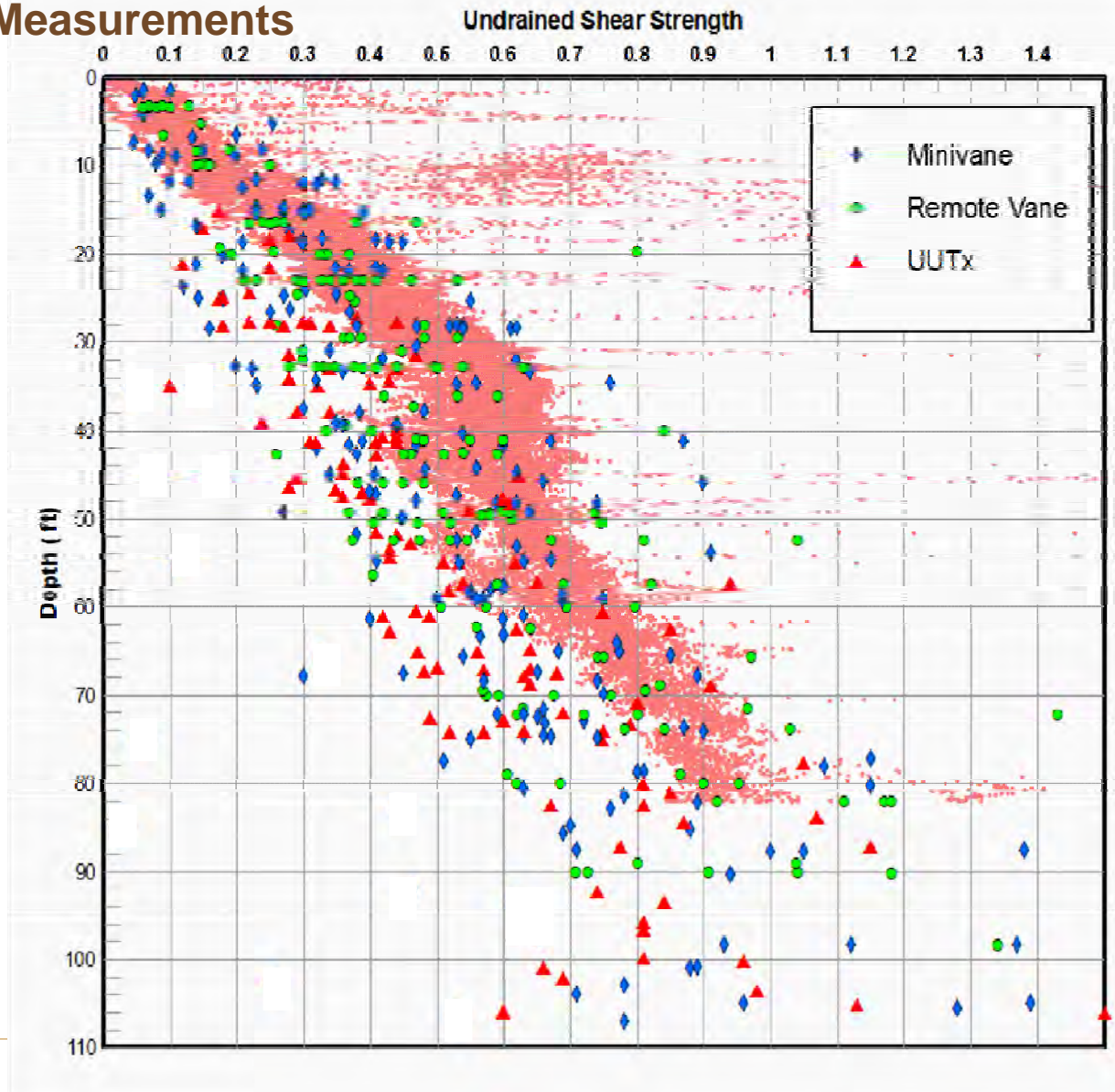

2007 Marine Site Investigation

- 125 CPTs, 16 borings up to 350 ft deep, 20 T-bars, 12 vane profiles, seismic reflection survey
 - GIS used to plan and supported in real time
- 4 Offshore sand borrow sites w/seismic 125 CPTs, 225 vibracores
- 1 onshore borrow site with 90 CPTs + 90 geoprobes
- Onshore SI program 35 borings and 45 CPTs (another firm)
- 10 borings and 20 CPTs in 2000

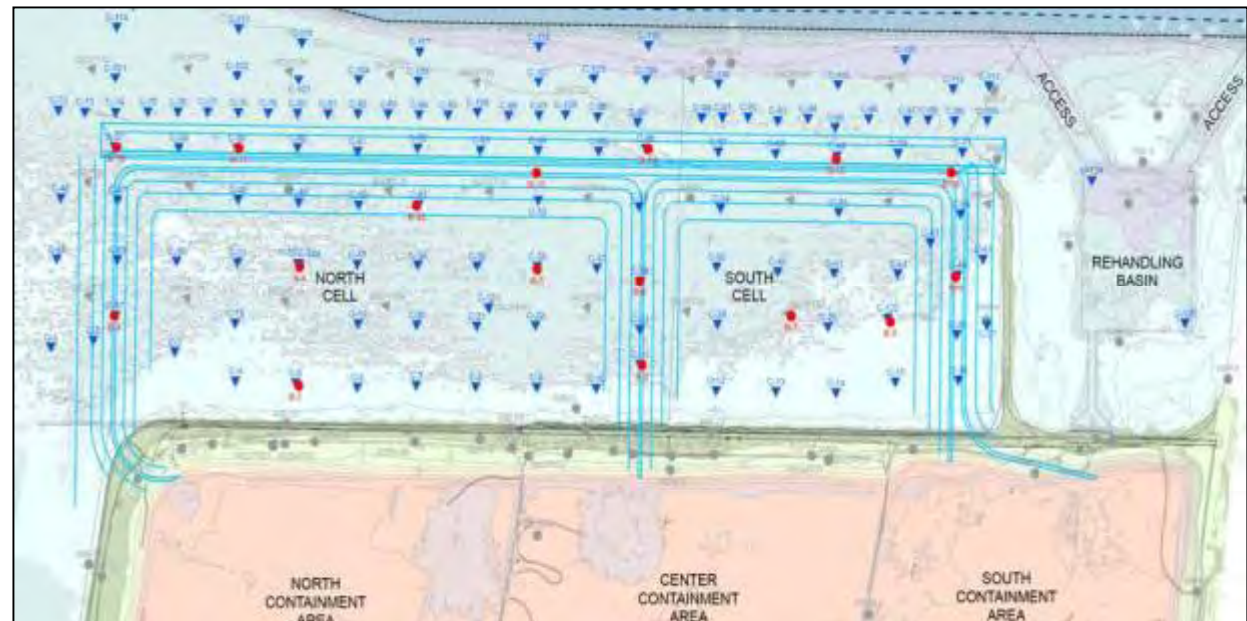

GIS used to plan and manage the data

Craney Island Project Example

Subsurface Stratigraphy and Conditions – Along Eastern Dike (Future Wharf) Alignment –

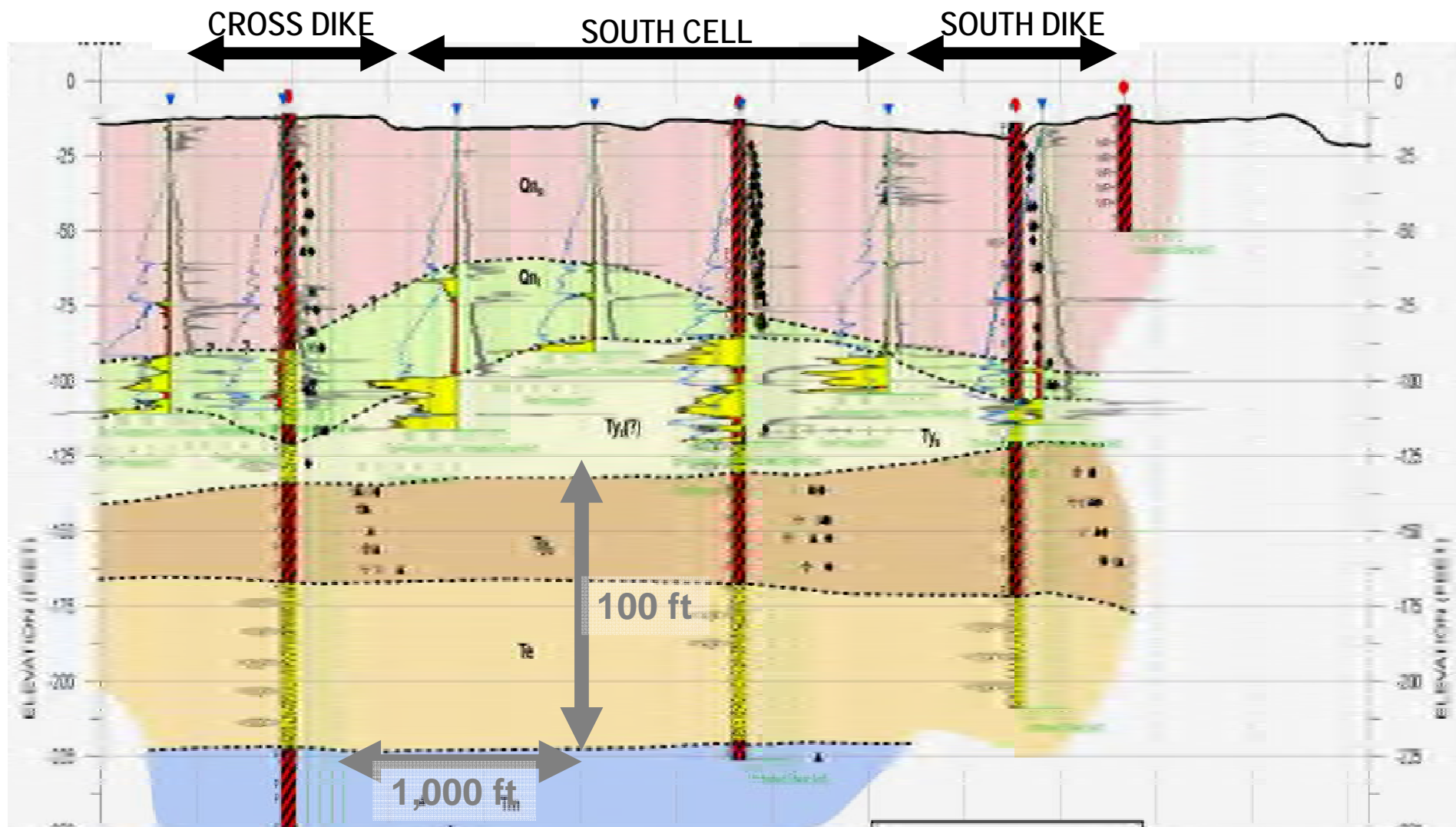



Isopach and Structural Maps of 7 Units





GIS Data Integration

- Geophysical data provides a 3D stratigraphic model
- Intrusive investigation data calibrates model in terms of depths and engineering properties
- GIS will act as a repository for all data collected on the site, for foundation analysis results and for as built information
- Building the 3D ground model is very important for D&B/P3 projects where bidders may wish to interpolate conditions for foundations remote from outline design positions, preventing the ground conditions risk being unnecessarily overpriced.

Case Study

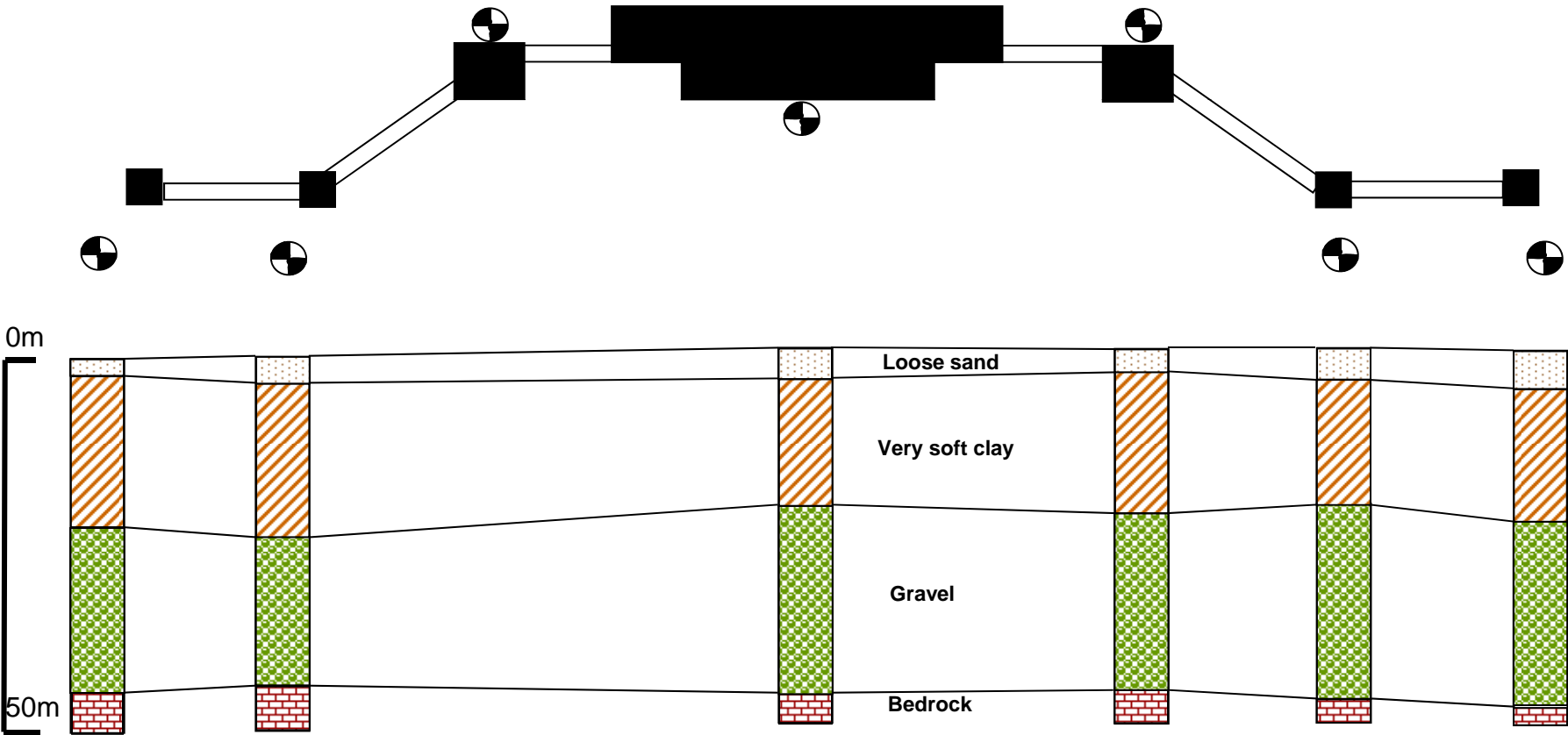

Case Study



Jack-up

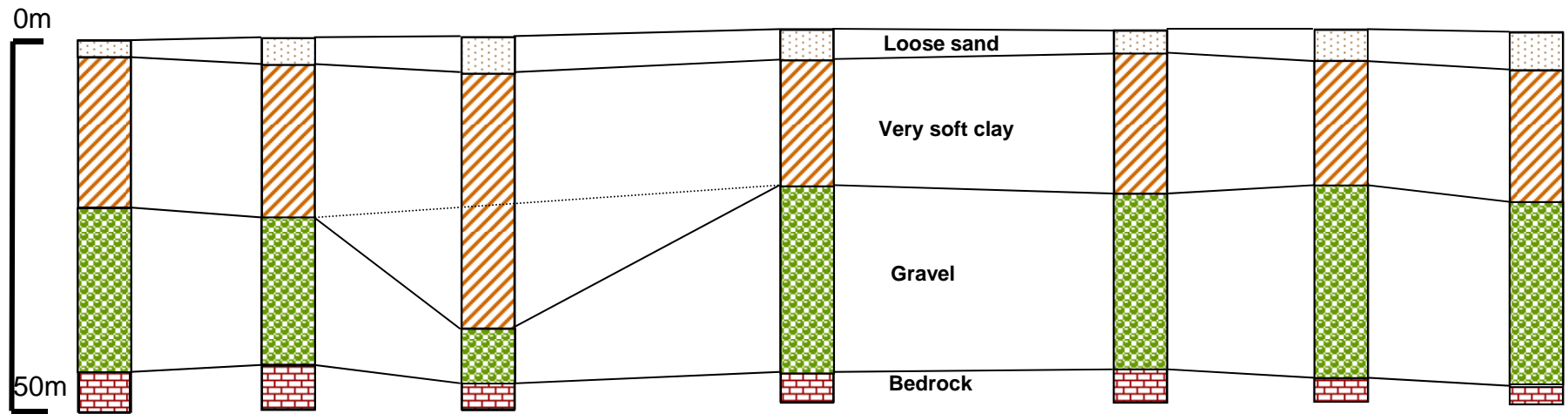
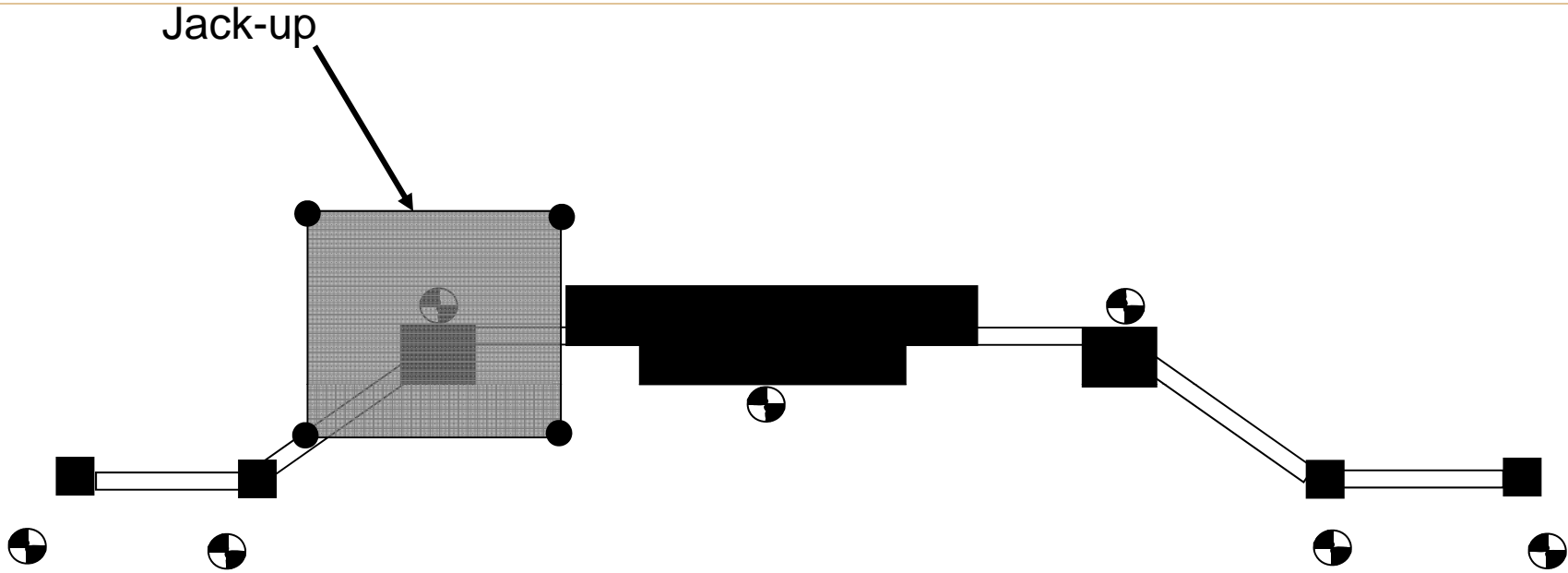

Improved Geological Model

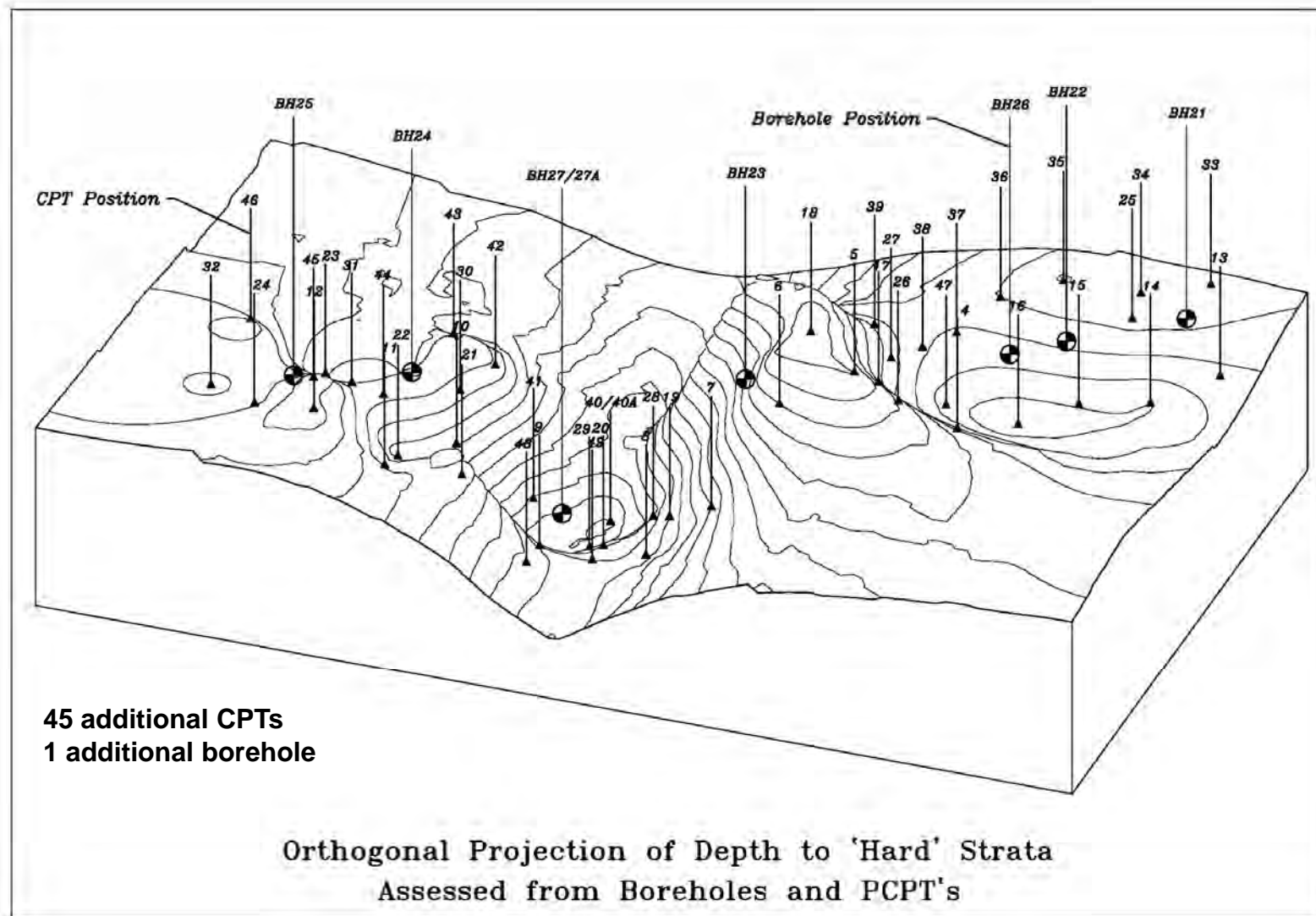

Thank You



Optimising Deep Foundation Design using Osterberg Cell Static Load Testing

Ray Wood
Fugro Consultants Inc.





Deep Foundation Uncertainty

- **Site Variability**
 - Axial, lateral, strength, stiffness, test quality
 - Typically test $< 0.01\%$ of site
- **Design Method**
 - Calibration, empiricism, codes, resistance or safety factors
- **Construction Quality**
 - Contractor experience
 - Quality of supervision

Reduce Cost by Reducing Uncertainty:



- **Informed characterisation (integrated investigation: geophysics + insitu testing + sampling)**
- **Design verification (testing)**
- **Optimization (redesign)**
 - **reduce length, size, number**
 - **change type (driven, drilled, anchor)**
 - **reduce cost and construction time (\$\$)**
 - **FLT's experience - savings 5X test cost**
- **Quality control testing to reduce cost of post-construction remediation**

Ratio of Measured / Estimated Capacity

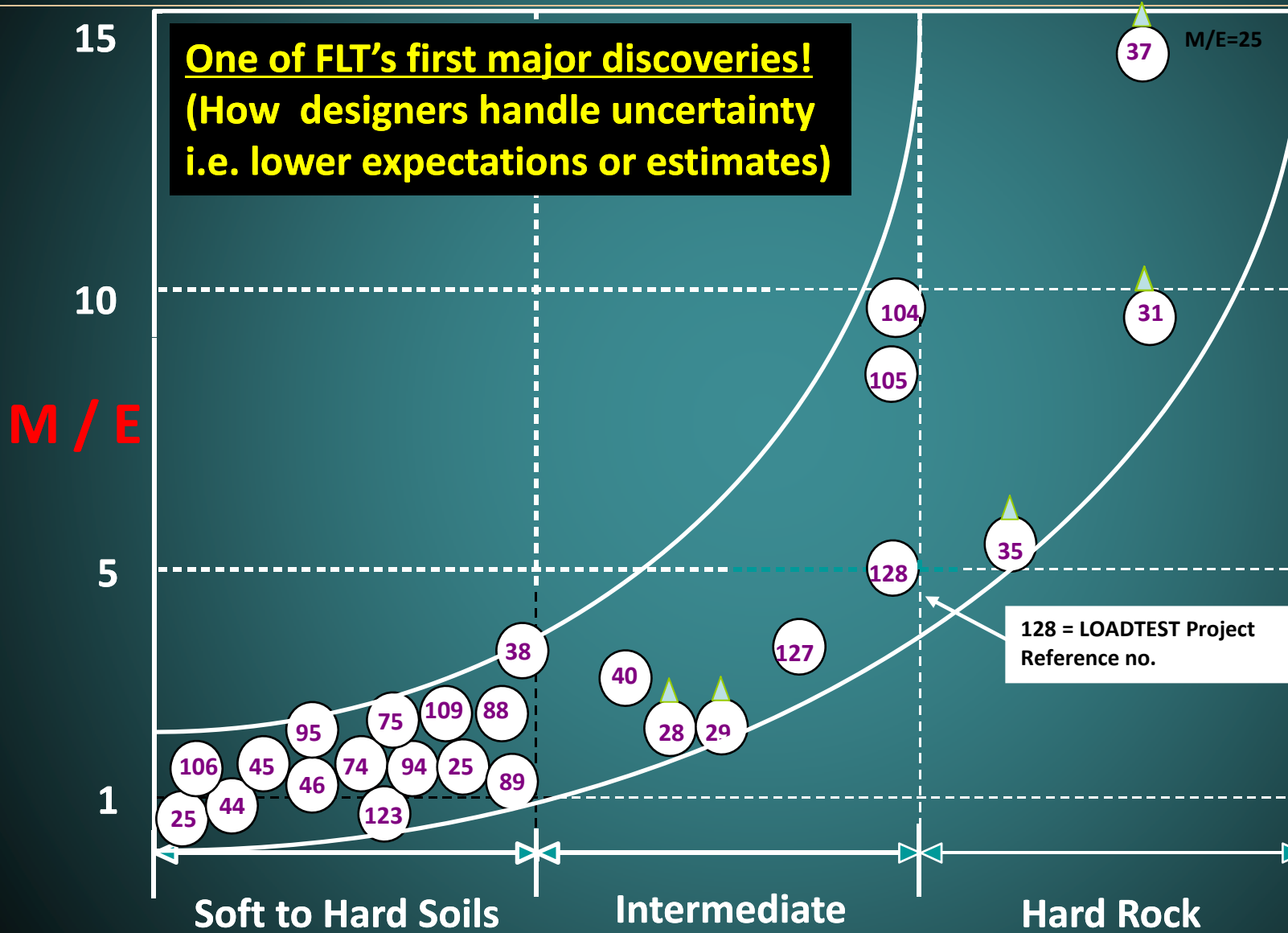

Ratio of Measured / Estimated Capacity

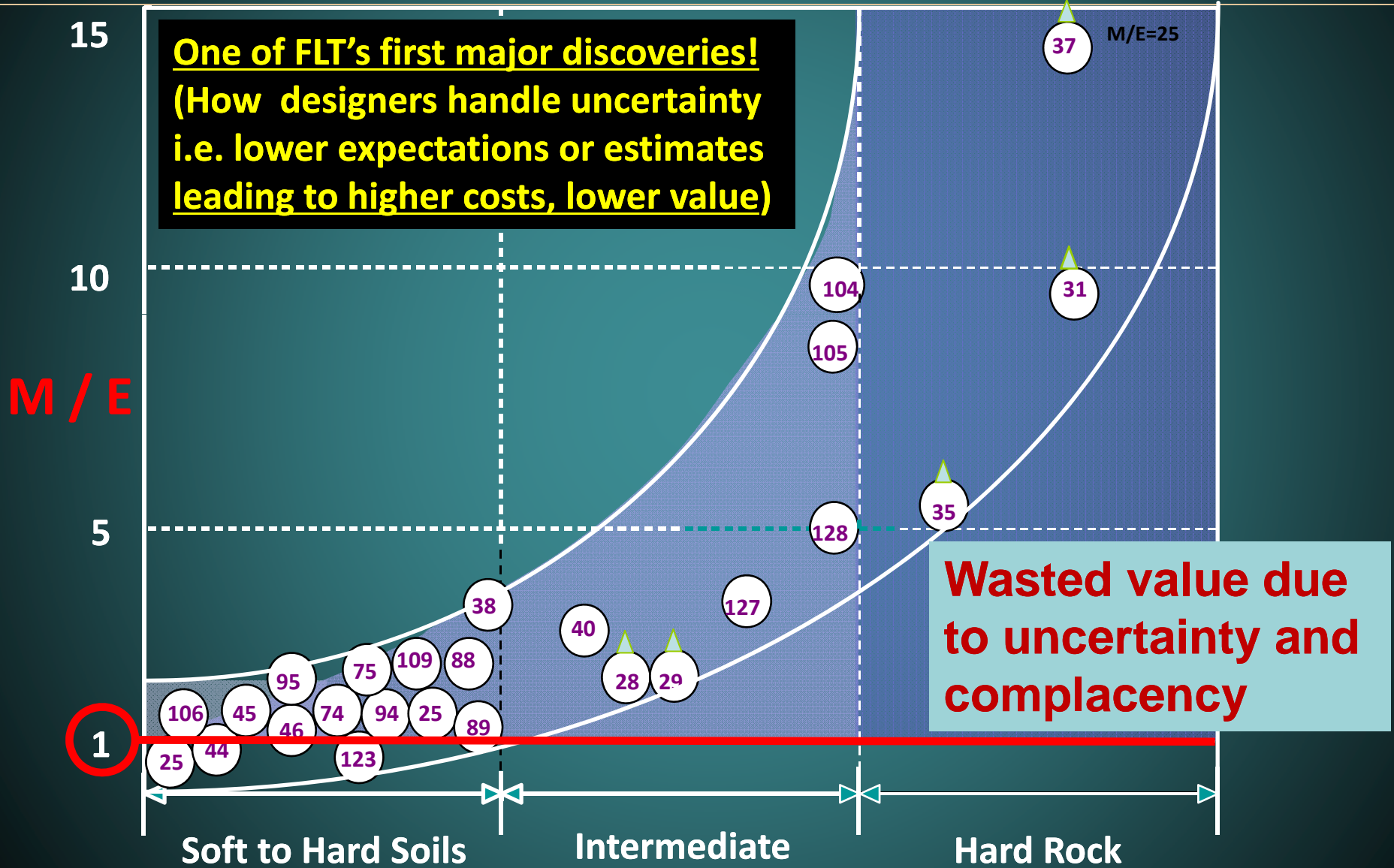



Economics of Uncertainty

- **Uncertainty leads to conservatism / cost**
- **Foundation designer should obtain feedback on the design cost**
- **Better design certainty provides cost savings that fund better site & foundation testing**
- **Consider design verification prior to finalizing plans (reduce contract uncertainty)**

Cost Savings: Secaucus, NJ Transfer Station



- **Initial Design**
 - 9 m Rock Sockets (“typical design”)
 - Design side shear: 1.3 MPa (code)
- **O-cell Tests**
 - 2 Shafts with 1.5 m rock sockets
 - Measured side shear: 2.7 MPa
- **Estimated vs. Actual Costs**
 - Foundation Cost Est.: \$18,000,000
 - Testing cost: \$255,000
 - Foundation redesign cost: \$8,900,000
 - Final design used 4.5 m rock sockets
 - Design FS = 3, Measured FS > 5
 - Redesign FS > 3
- **experience shows sizable project savings as a result of load testing. More than 70% of testing saved the client money.**





Foundation Savings After Testing Based On Actual Jobs Completed

Job Number	566	775	835	381	056*	335	426	635
State	CA	FL	NC	NJ	SC	GA	TX	FL
Foundation Cost Estimate	\$850,000	\$6,200,000	\$32,500,000	\$18,000,000	\$160,000,000	\$3,276,000	\$8,500,000	\$4,520,000
Foundation After Test	\$610,000	\$4,980,000	\$24,500,000	\$8,900,000	\$125,000,000	\$3,003,000	\$8,500,000	\$7,232,000
Savings	\$240,000	\$1,220,000	\$8,000,000	\$9,100,000	\$35,000,000	\$273,000	\$0	-\$2,712,000
Test Cost	\$79,000	\$365,000	\$2,000,000	\$255,000	\$7,500,000	\$240,000	\$95,000	\$305,000
NetSavings	\$161,000	\$855,000	\$6,000,000	\$8,845,000	\$27,500,000	\$33,000	-\$95,000	-\$3,017,000
Calculated Factor of Safety	2.5	3.0	3.0	3.0	3.0	3.0	3.0	2.5
Measured Factor of Safety	3.0	3.5	4.0	5.0	NA	3.5	9.5	0.8
Factor of Safety After Redesign	2.0	2.0	2.0	2.0	2.0	2.3	9.5	2.0

- In our experience we have seen sizable project savings as a result of load testing.
- More than 70% of the testing we have done saved the client money.
- Of the remaining 30%, more than half didn't realize the savings because the testing was done too late in the project.
- In only a few cases, the engineers estimates were so close to the measured ultimate that the foundation did not need to be modified.



Deep Foundation Tests

- **Static Testing (most reliable)**
 - Uni-Directional Static Load Testing (traditional top-down, automated?)
 - Bi-Directional Static Load Testing (O-cell)
- **High Strain Dynamic Testing (PDA)**
- **Quality Control / Quality Assurance**
 - Driven Piles: Blow Count, Hammer Energy
 - Shafts: Slurry, Excavation Log, Shaft Profile (Sonic Caliper), Bottom Cleanliness (MSID), Concrete, Pile Integrity Test, Crosshole Sonic Logging, Thermal, Gamma

3000 Ton Load Frame

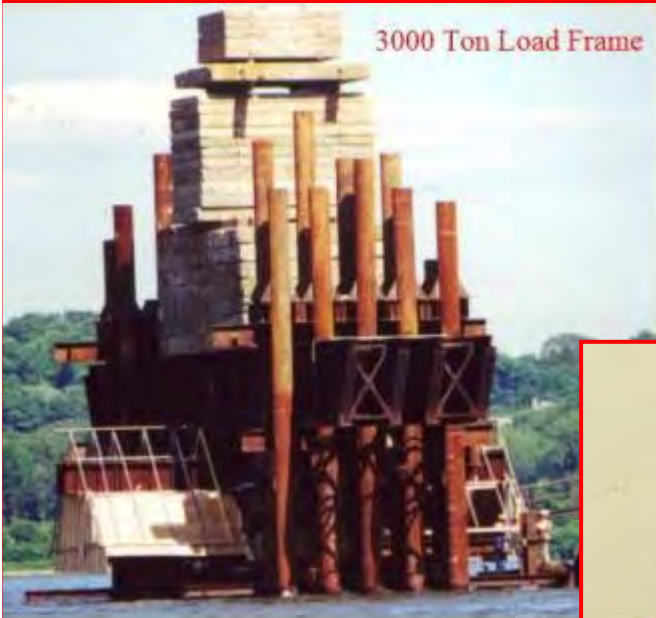

Uni-Directional Static Load Tests ASTM D1143



Need reaction frame
Minimum 2X design load
Possible safety issues
High cost (time and \$\$)



Reaction Beam Collapse

Due to tension bar failure



from FPS Load Testing Handbook 2006



~3000 tonnes of Kentledge in Singapore





Introduction to O-cell Testing



O-cell Instrumentation

- O-cell Expansion Transducers
- O-cell Top Telltales
- Pile Top Deflection
- Pile Bottom Telltales
- Shaft Strain Gauges
- Embedded Shaft Compression Transducers

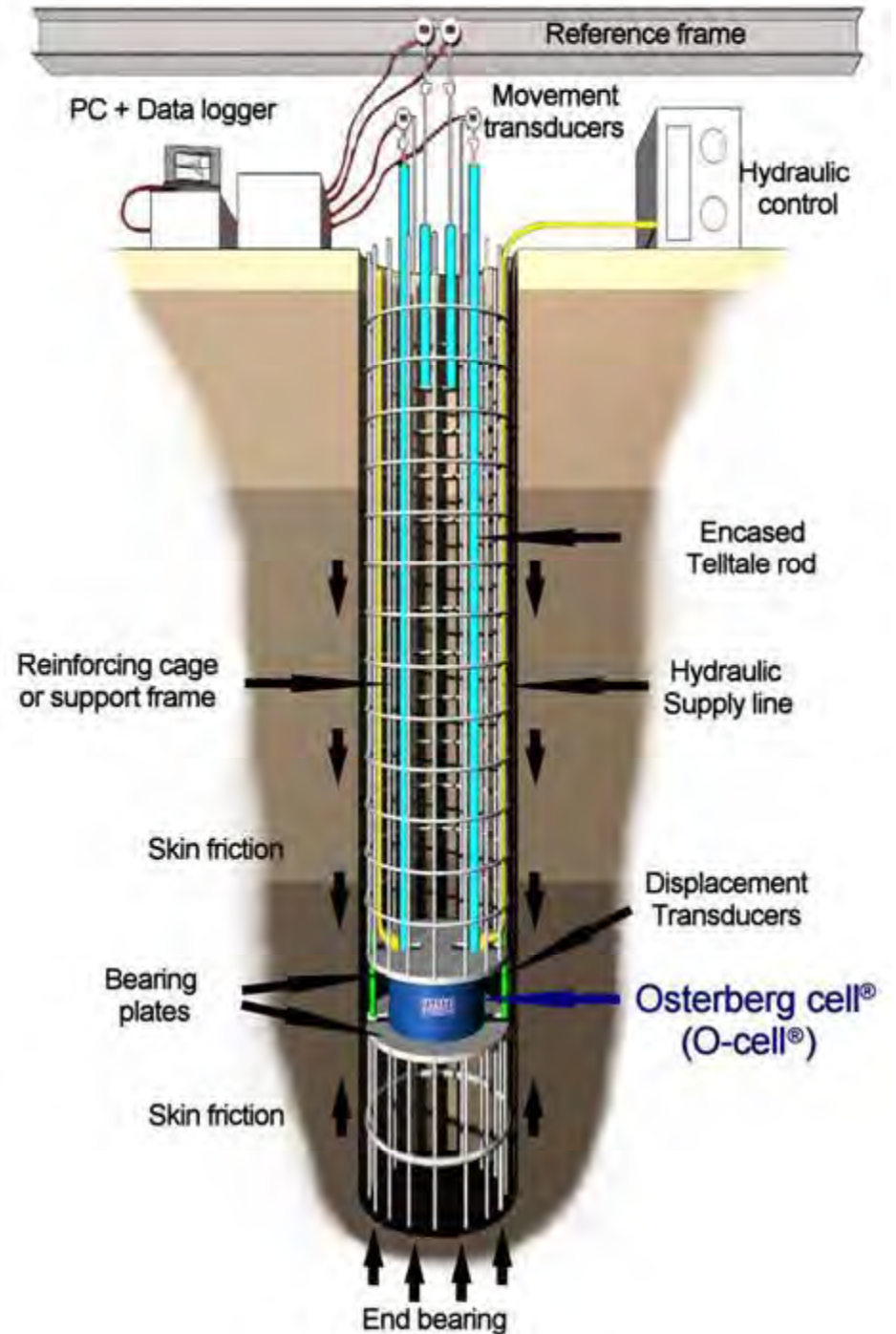

Reaction System

Osterberg Cell Test

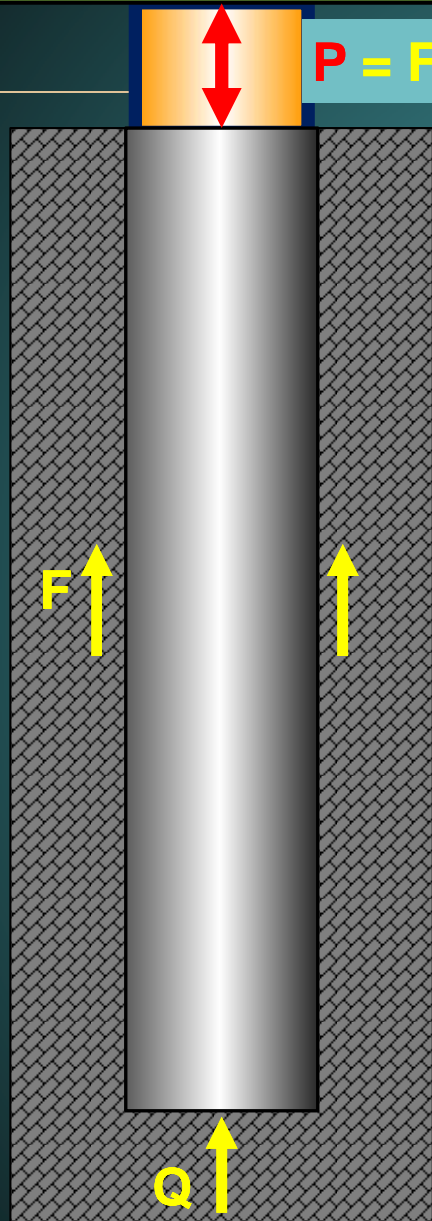

Top-Down Test

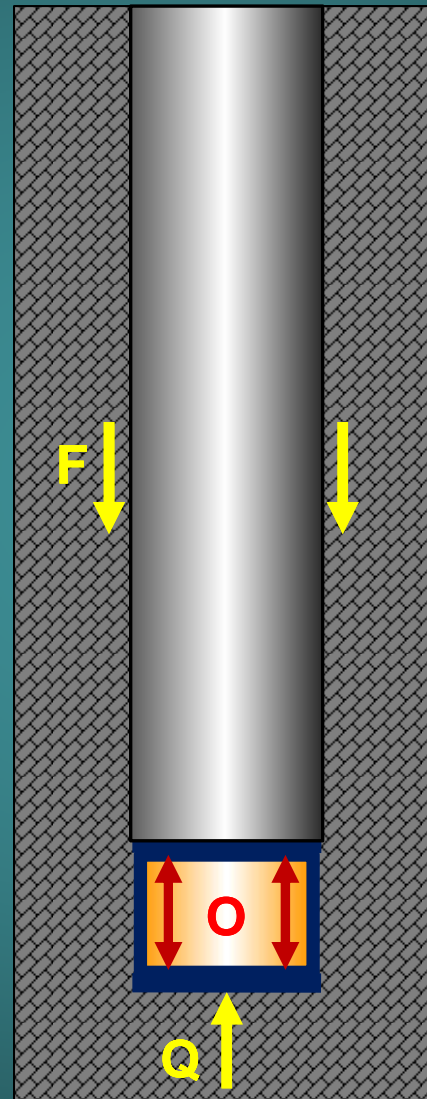

$O = F = Q = P/2$

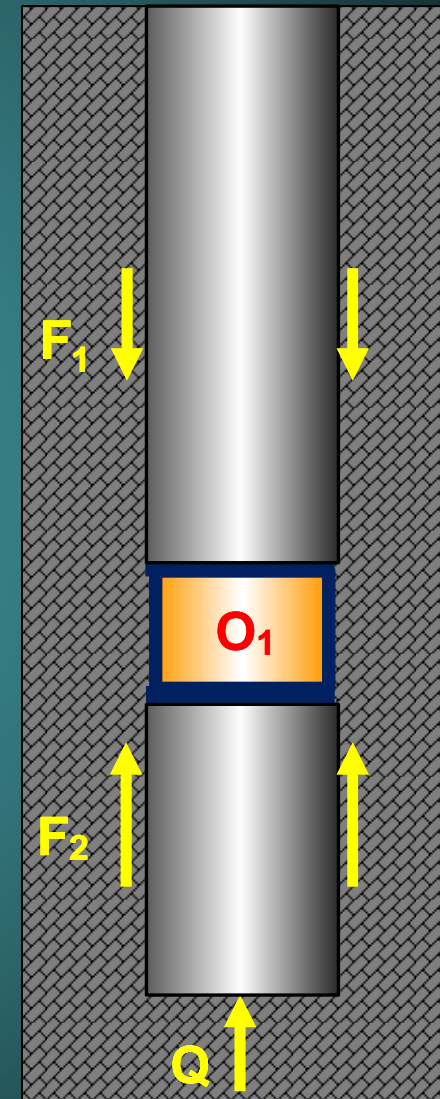

$O_1 = F_1 = (F_2 + Q)$

O-cell Separates Bearing from Side Shear

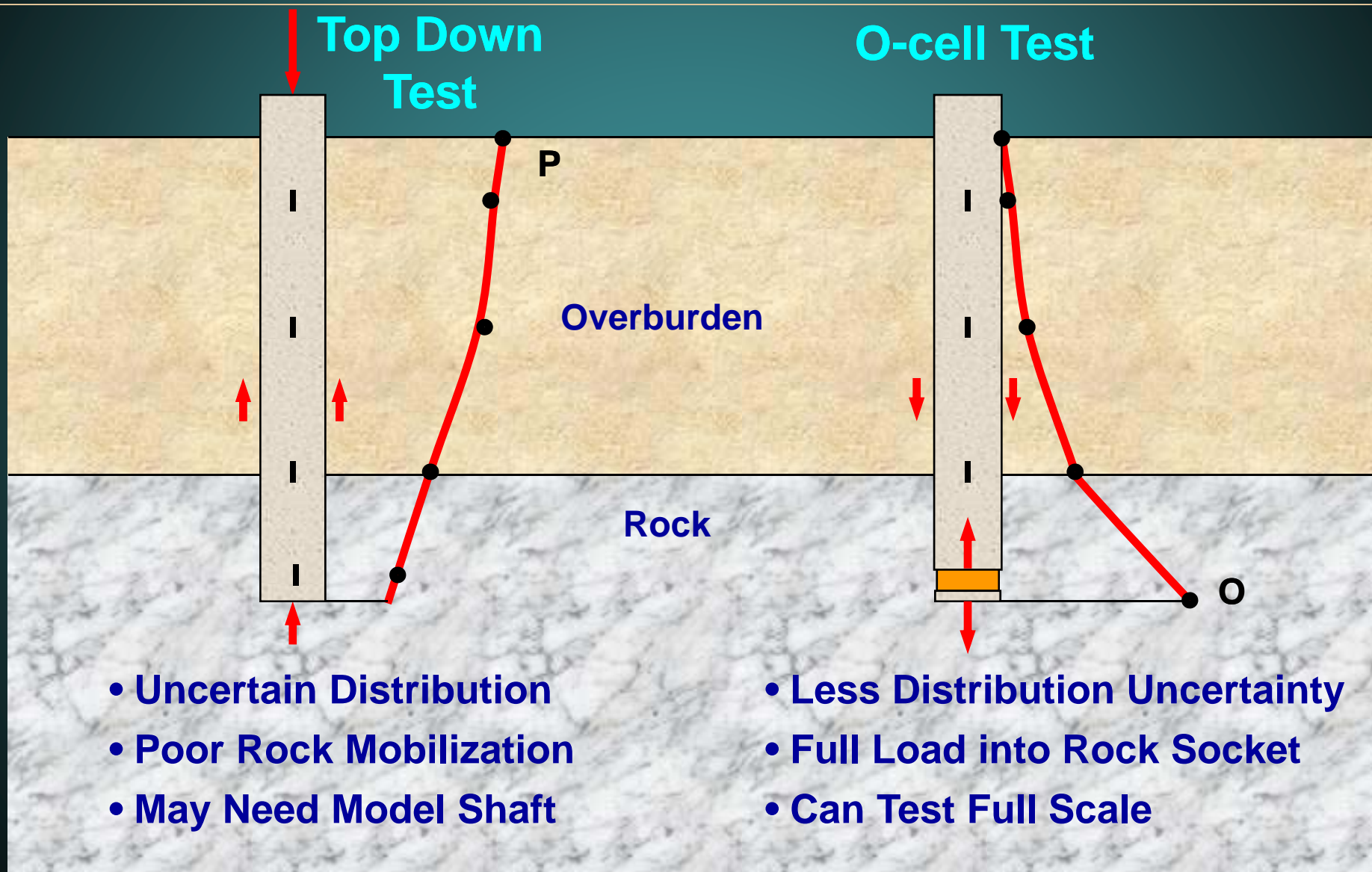

Multiple O-cell Assemblies



Attaching O-cells to bottom plate

Multiple O-cell Assemblies



Attaching O-cells to top plate

Single O-cell Plate Assembly



← Cone-shaped tremie guide

O-cells in CFA piles



O-cells in CFA piles



Maximum size/loads tested to date

Pile Diameter [mm]	600	750	900	900
Pile Length [m]	38	40	35	36
O-cell Diameter [mm]	405	540	660	2x540
Mobilized Load [MN]	17.5	32	32	46



O-cells in Precast Piles



**Sizes tested
to date**

**Pile Section
[mm]
300 mm
450 mm
600mm
750 mm**

Test Setups



Modern O-cell - No Reference Beams



**The contractor can demobilize, saving time and money
Accuracy actually improved (Sinnreich, Simpson, DFI Journal, 2009).**

Modern O-cell Test Set up



Leica digital levels monitor top of shaft directly

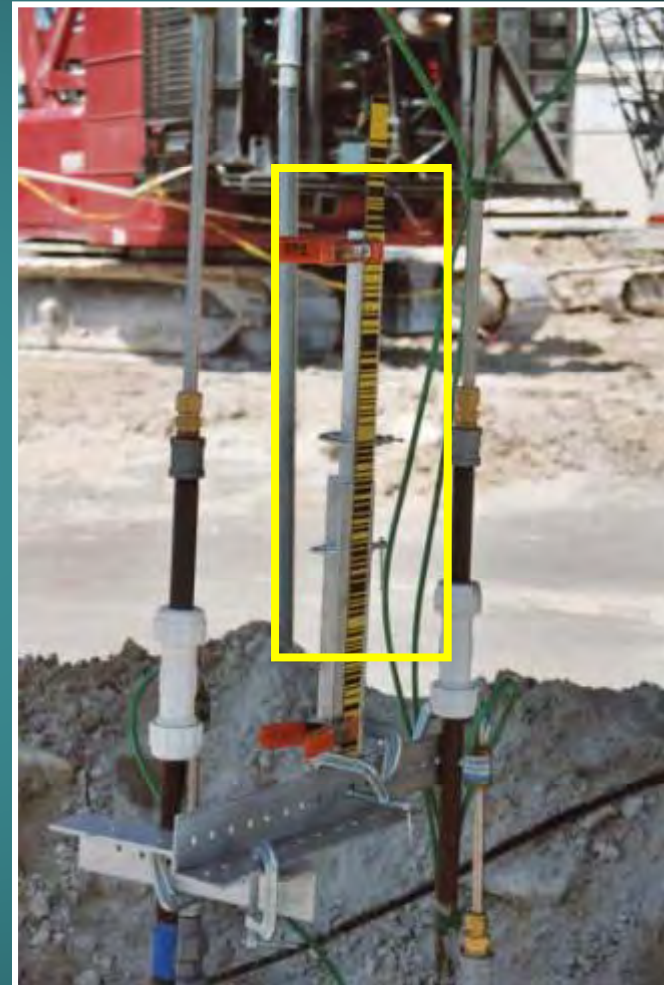

Leica digital levels target a staff on the top of shaft

Complete Test Setup





O-cell Static Load Test Advantages

- Test drilled shafts (wet/dry), CFA piles, driven concrete or steel piles, barrettes
- Separates side shear & end bearing
- Very high load capability (321MN, St. Louis)
- Direct loading of rock socket
- Cost, safety, and space advantages
- No additional reaction system needed
- Doubles effective jack load
- Post-test grouting for production piles



O-cell Test Limitations

- **Shaft preselected**
- **Maximum load limited by weaker of end bearing or side shear (use multi-level)**
- **Top of pile not structurally tested**
- **Must construct equivalent top load movement curve**
 - use the sum of measured behavior
 - use the sum of modeled behavior
 - use from finite element, t-z approach

Typical O-cell Test Result

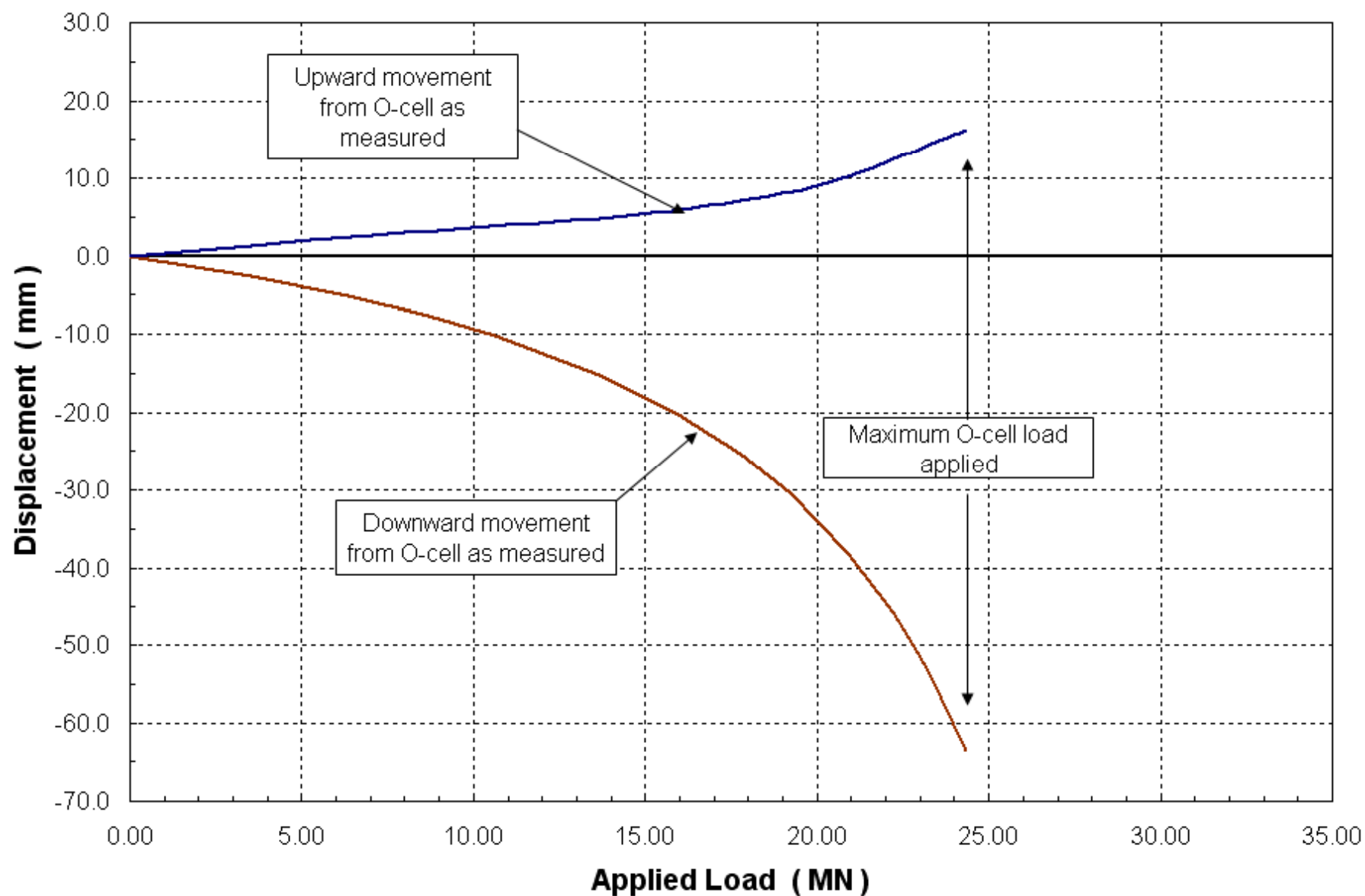

Equivalent Top-Load Curve

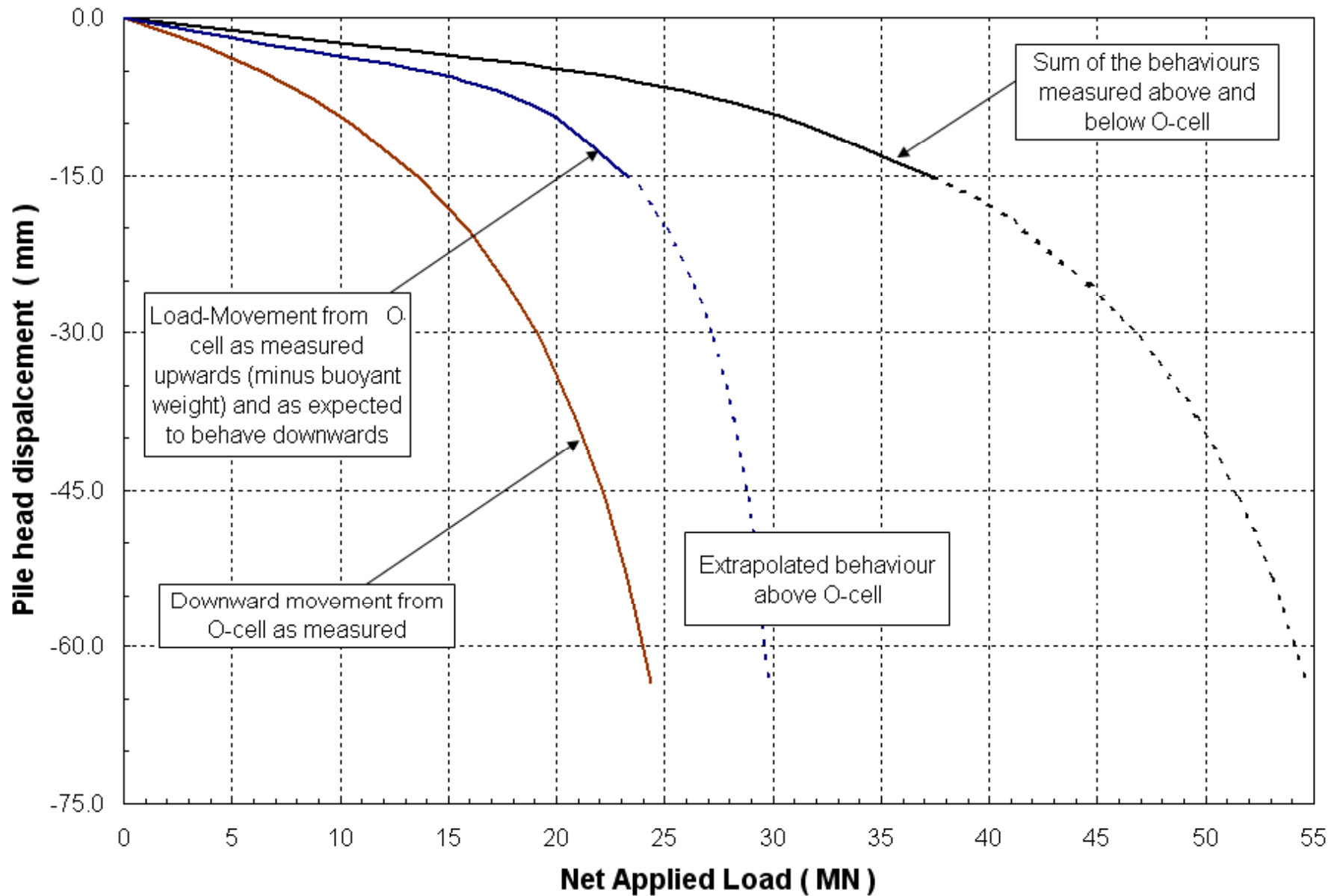

Equiv. Top-Load + Elastic Shortening

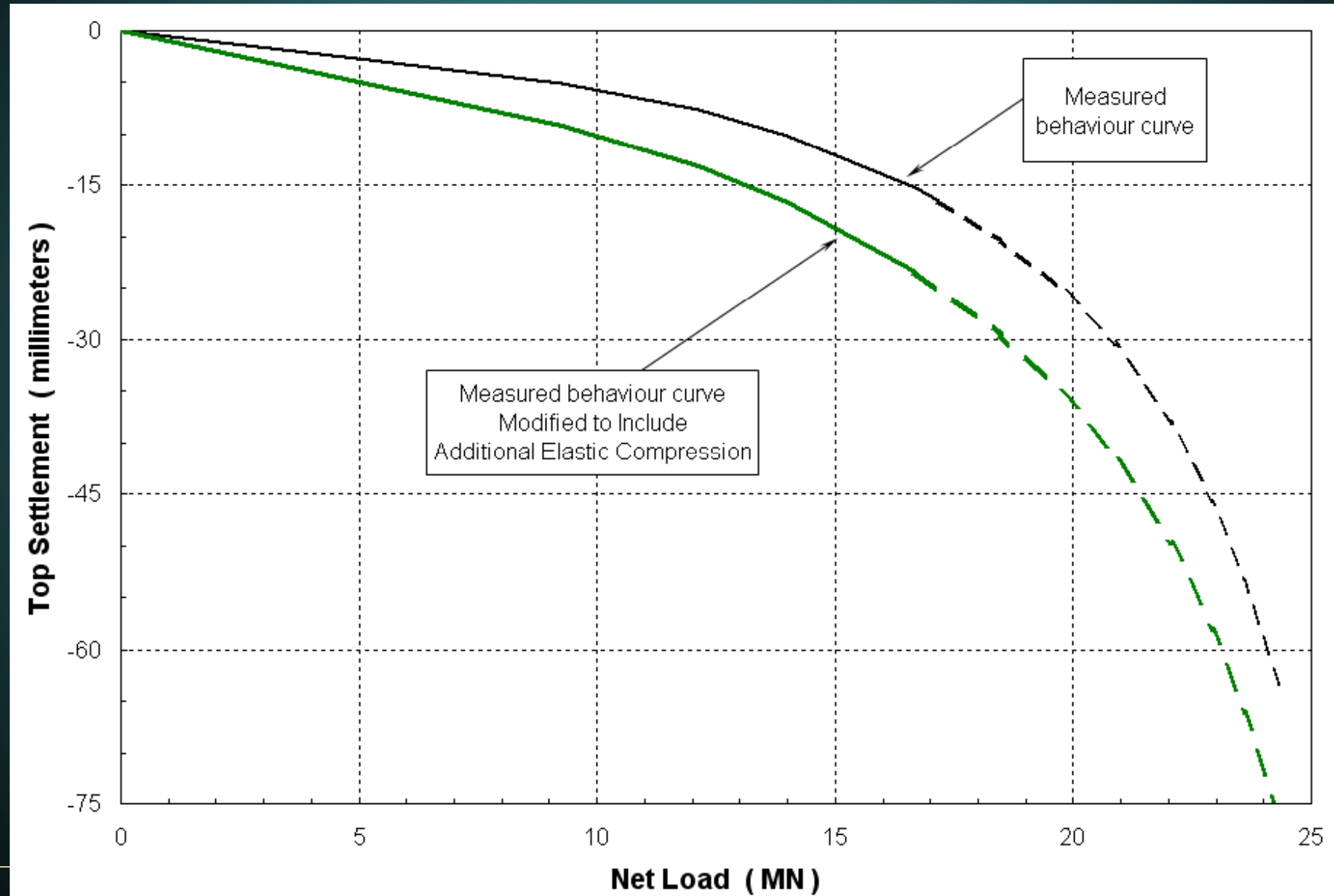

Side Shear from Strain Gauges

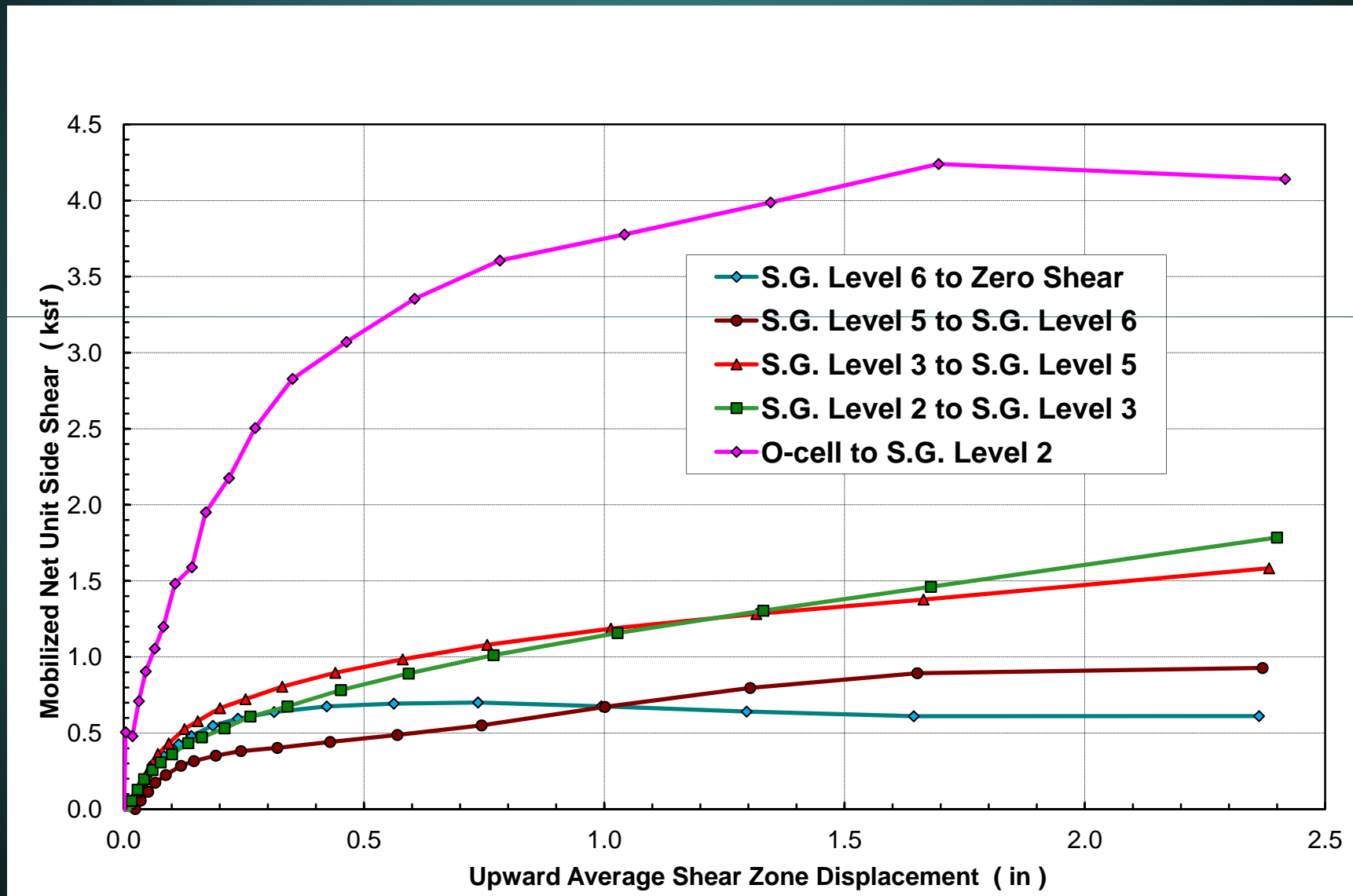

Load Transfer Diagram

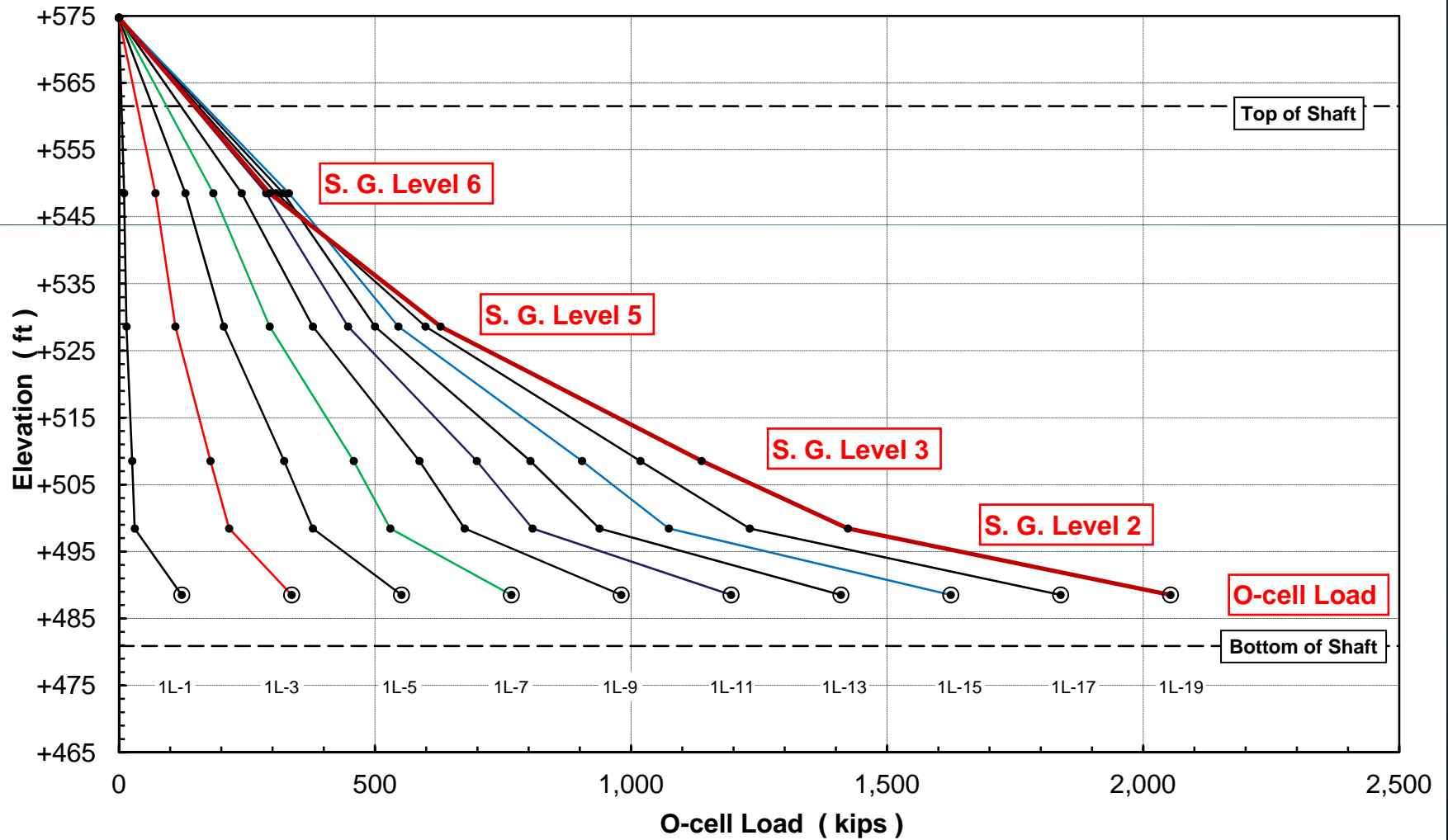



LRFD Example (Based on Actual Project)

- Cost of Foundation Design Cost \$4 Million
- \$40,000 in engineering and testing included
- \$200,000 load test program proposed
- Simplified foundation (uniform site and depth)
 - $N = 100$ shafts
 - Length = 100 feet deep, $R = \phi R_N$
 - Unit Cost = \$400 per foot
 - Total Cost = \$4 million
- $\phi = 0.55$ before load test, $\phi = 0.70$ after load test
- After load test, R increases by 27% ($\phi = 0.55 \rightarrow 0.70$)

But design assumptions are typically conservative and we have ignored the value of the load test result ...



Design Capacity Estimate

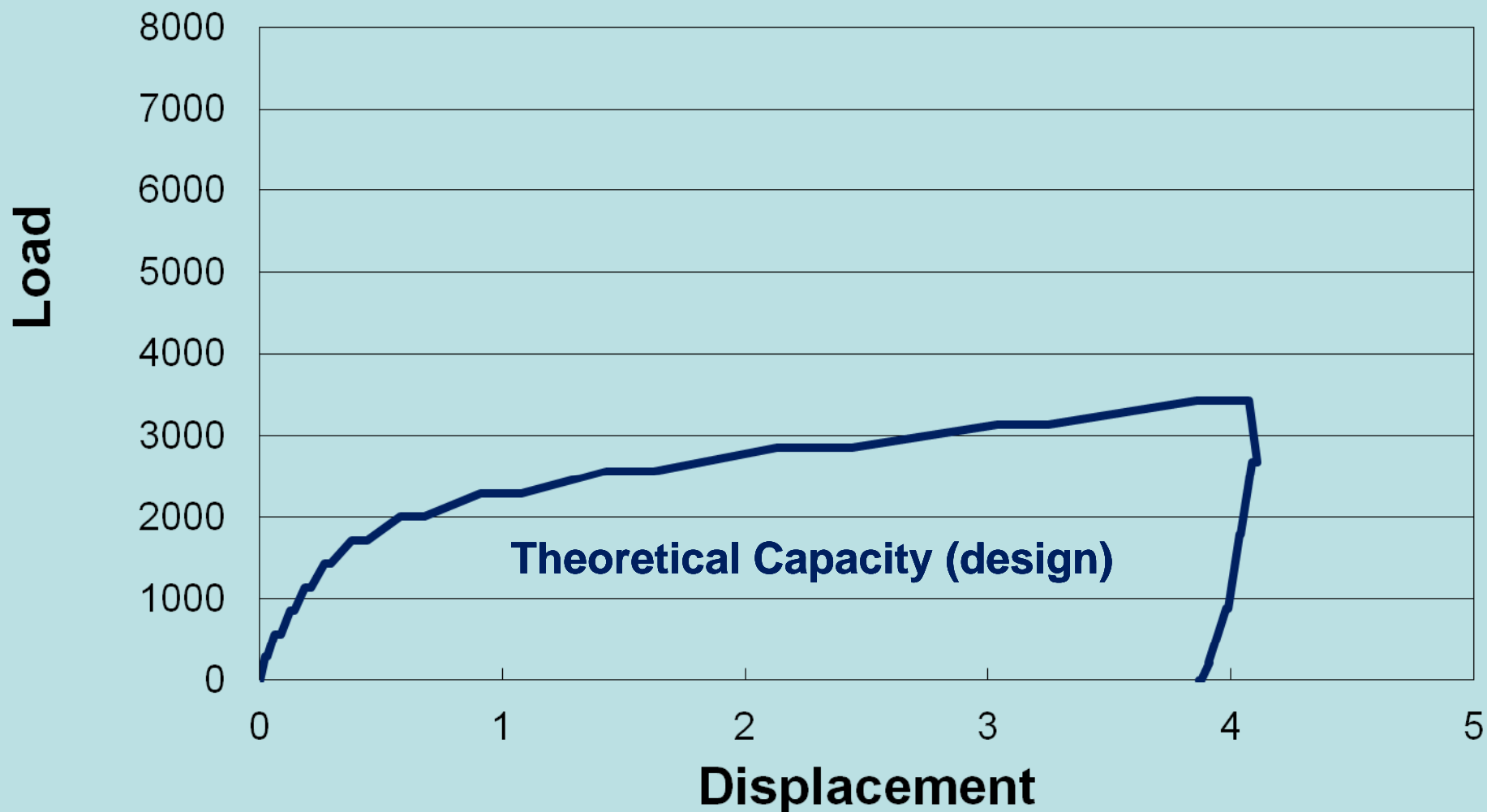

Advantage of Load Testing

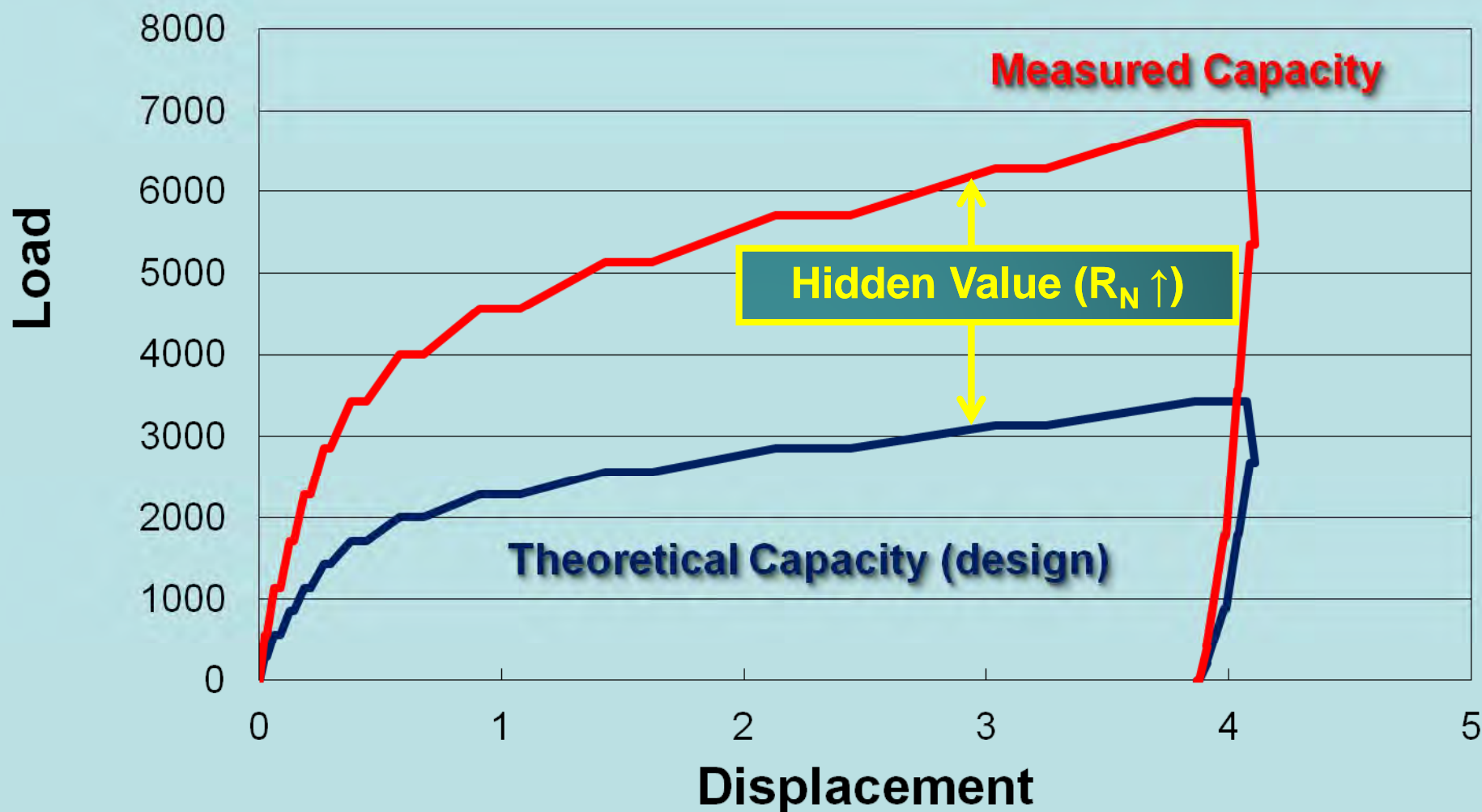



LRFD Example

- Cost of Foundation Design Cost \$4 Million
- \$40,000 in engineering and testing included
- \$200,000 load test program proposed
- Simplified foundation (uniform site and depth)
 - $N = 100$ shafts
 - Length = 100 feet deep, $R = \phi R_N$
 - Unit Cost = \$400 per foot
 - Total Cost = \$4 million
- $\phi = 0.45$ before load test, $\phi = 0.60$ after load test
- After load test R increases by 27%, R_N increases by 100%
- Net effect: R increases by $2 \times 1.27 = 2.54$
- After load test, Length and Total Cost decrease by say 40%
- Total Cost = $(\$400/\text{ft})(60 \text{ ft})(100 \text{ shafts}) = \2.4 million



LRFD Example

Original foundation cost = \$4 million + \$40,000 =
\$4,040,000

New cost = \$2.4 million + \$40,000 + \$200,000 = \$2,640,000

Savings = \$1,400,000

Sell It to the Owner

Foundation System 1

Includes Basic Engineering and Site Investigation

LRFD, $\phi = 0.45$
Theoretical Ultimate
Cost = \$4,040,000

Foundation System 2

Includes Basic Engineering, Site Investigation and O-cell Testing

LRFD, $\phi = 0.60$
Actual Ultimate
Cost = \$2,640,000

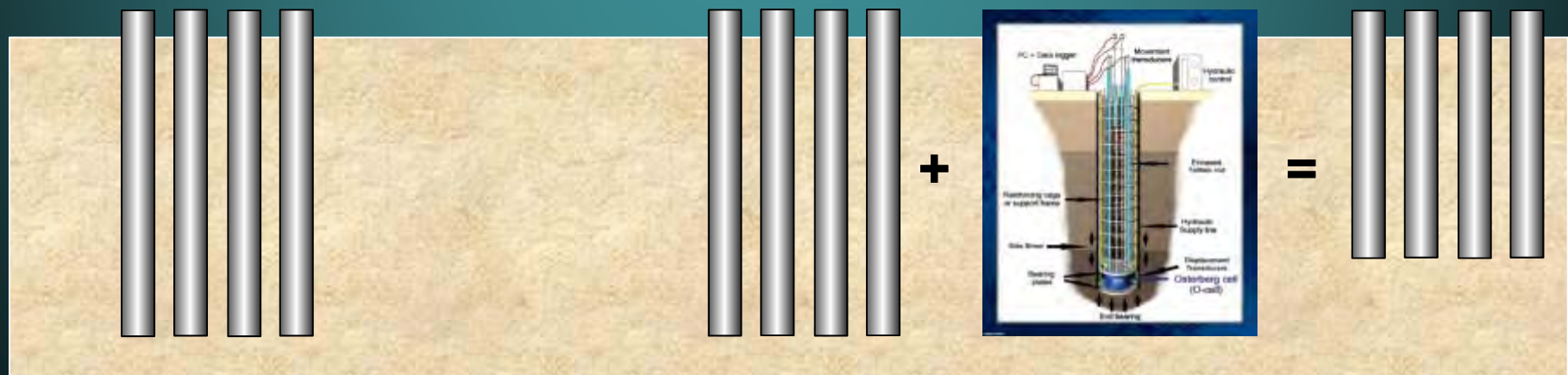

Multilevel testing



**Test is performed in stages
to fully mobilize capacity**

Multilevel testing Stage 1



Mobilize End Bearing

Middle cell closed

Lower cell pressurized

Multilevel testing Stage 1

Downward movement below bottom O-Cell

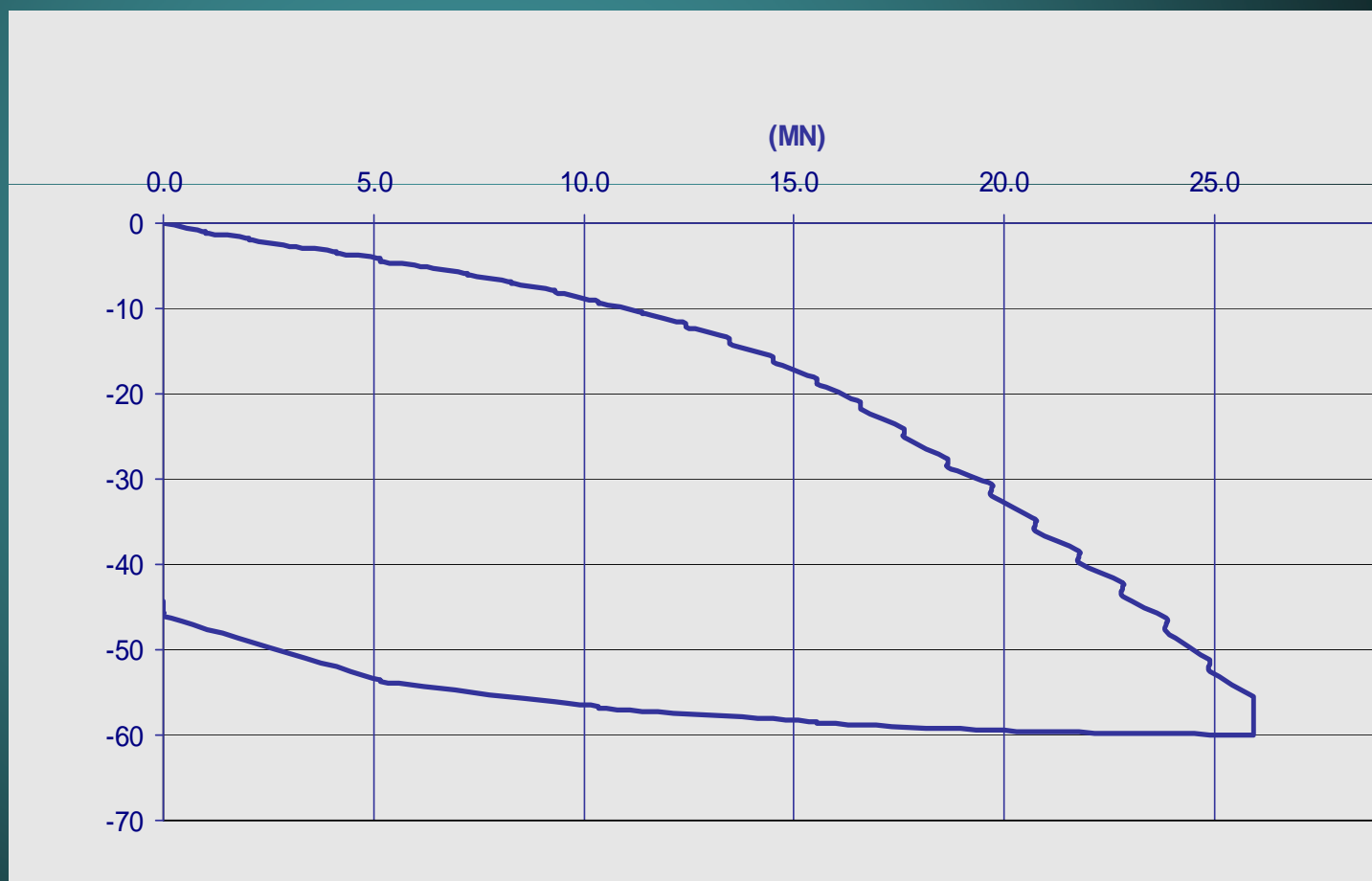
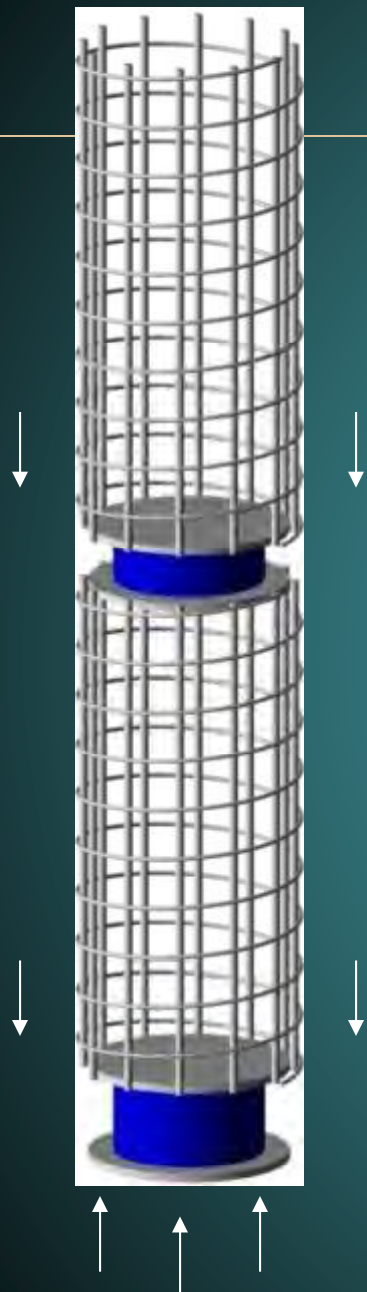

Multilevel testing Stage 2



**Mobilize Side Shear
Between O-cells**

Middle cell pressurized

Lower cell draining

Multilevel testing Stage 2

Downward movement below middle O-Cell

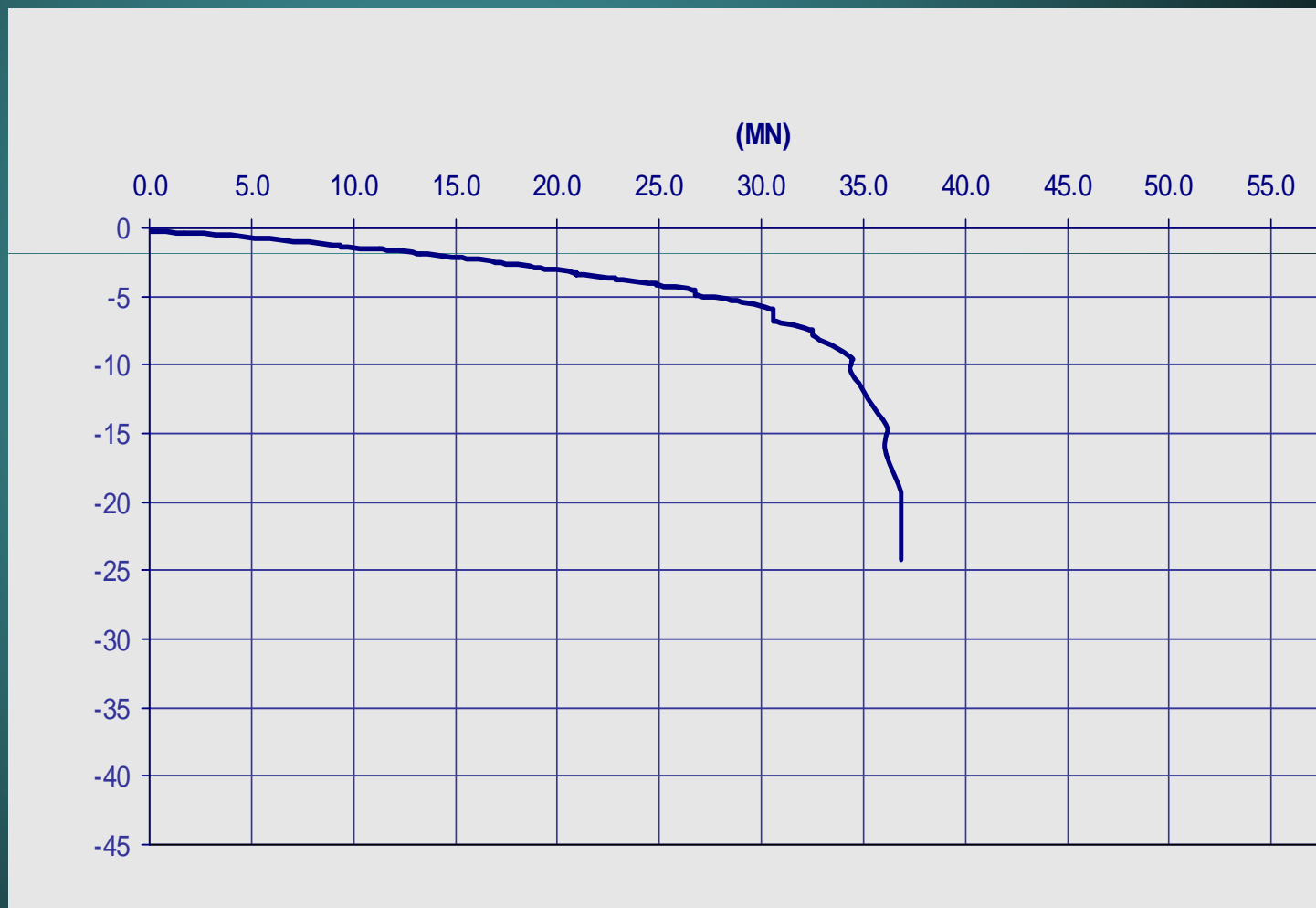

Multilevel testing Stage 3

**Mobilize Side Shear
Above Middle O-cell**

Middle cell pressurized

Lower cell hydraulically closed

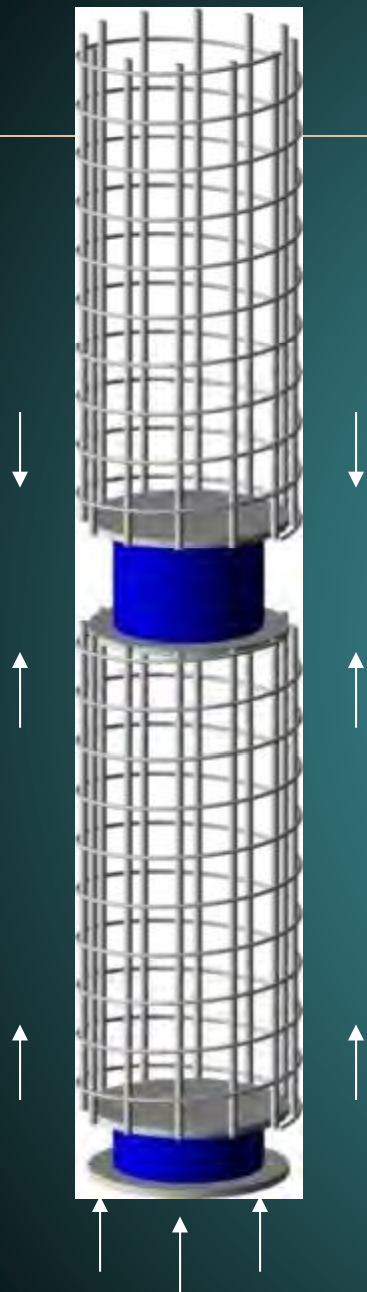

Multilevel testing Stage 3

Downward movement below middle O-Cell

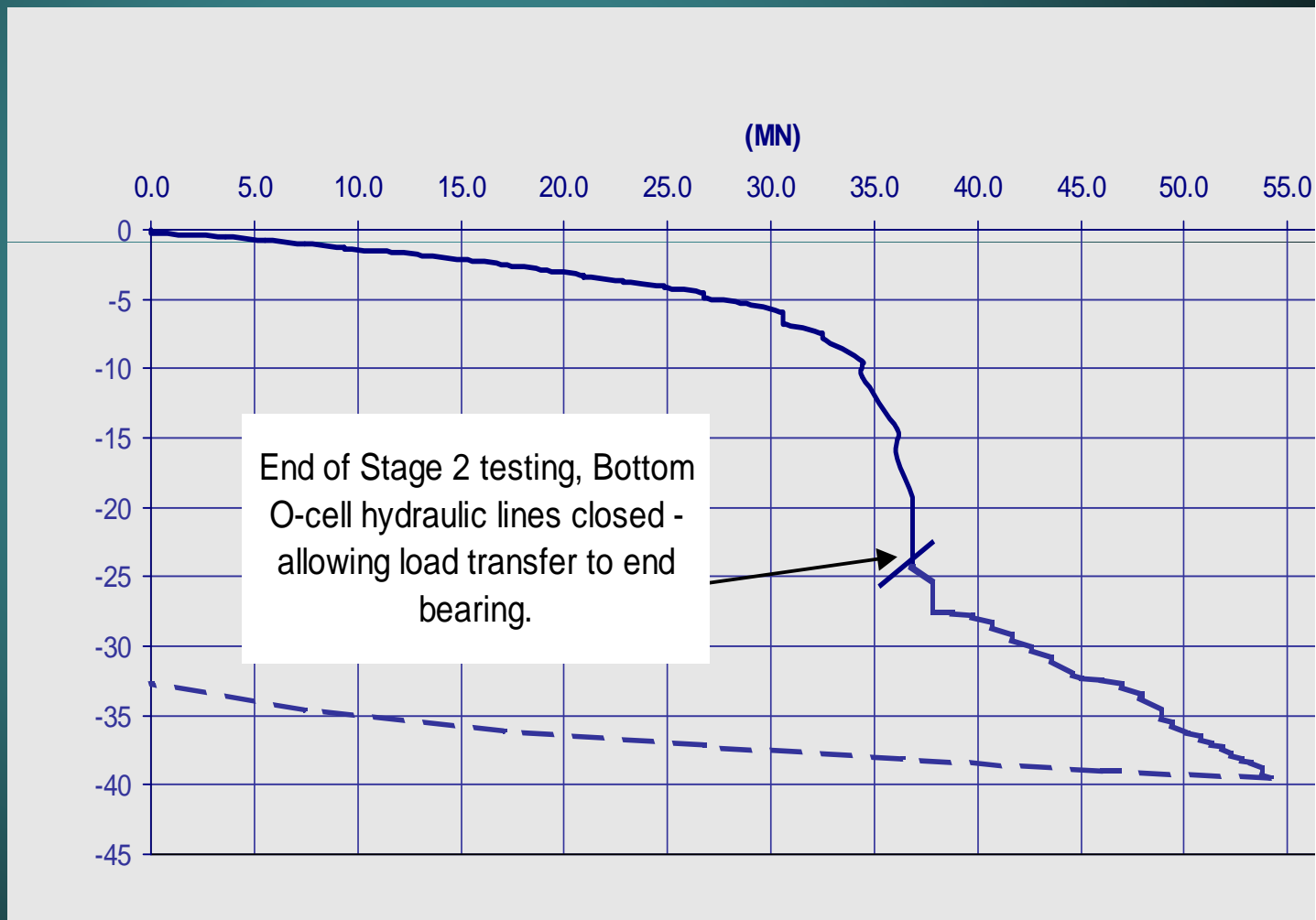

Multilevel testing Stage 3

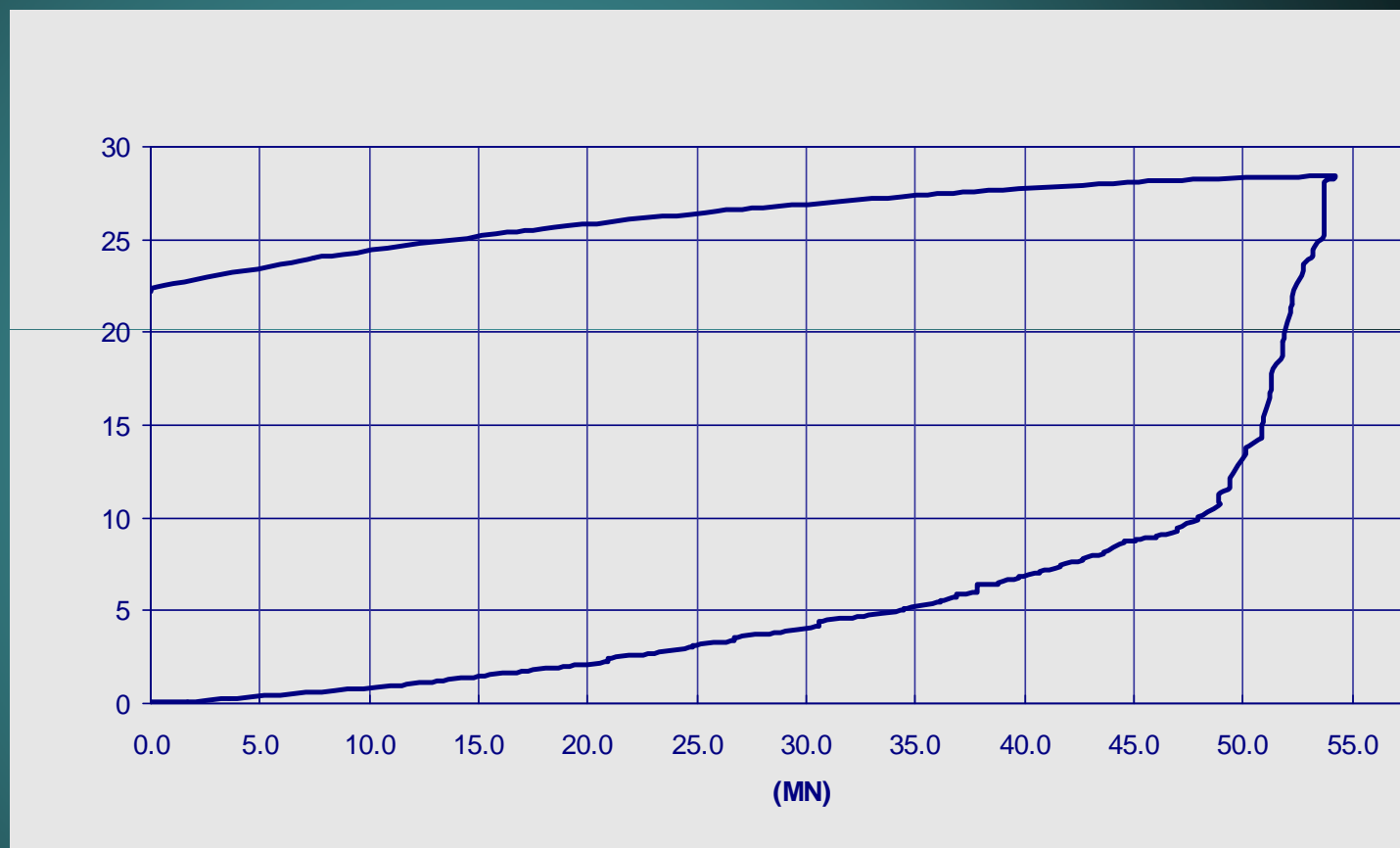

Upward movement above middle O-Cell



Equivalent top load-settlement curve

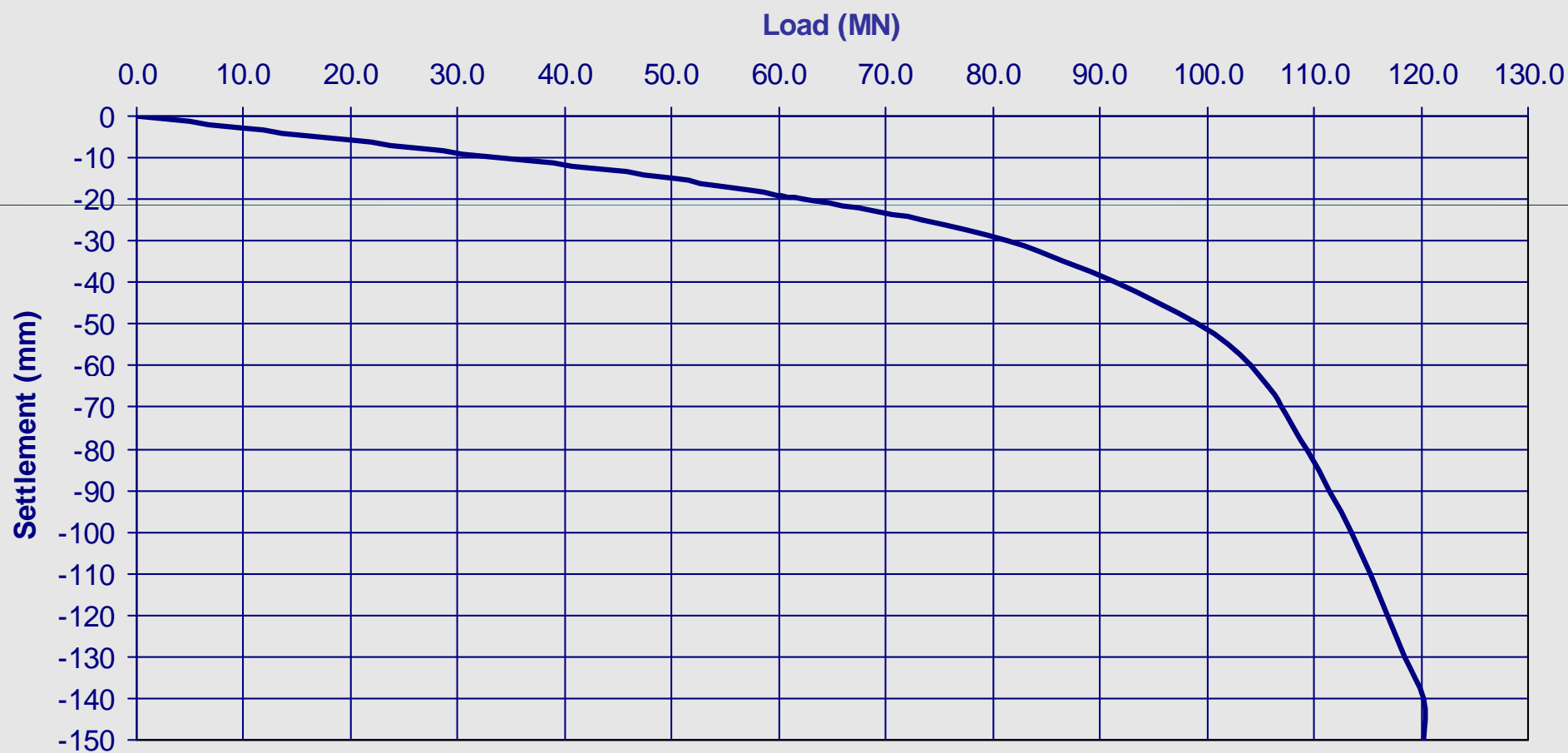



O-Cell World Records (short list)

2010 - Mississippi River Bridge, St. Louis, MO	36,067 tons (321 MN)
2010 - Incheon 2nd Link, Incheon, Korea	31,350 tons (279 MN)
2003 - Pomeroy OH - Mason WV, Ohio River	18,400 tons (163 MN)
2006 - Amelia Earhart Bridge Kansas City, KS	17,800 tons (158 MN)
2001 - Tucson, AZ	17,000 tons (151 MN)
2002 - San Francisco	16,500 tons (146 MN)
1997 - Apalachicola River, FL	15,000 tons (135 MN)

Incheon 2nd Link, Korea



Incheon 2nd Link, Korea



O-cell Application: Barrettes



Las Vegas



Barrettes - St. Petersburg, Russia



- 60 m deep
- 90 MN capacity

Barrettes - St. Petersburg, Russia

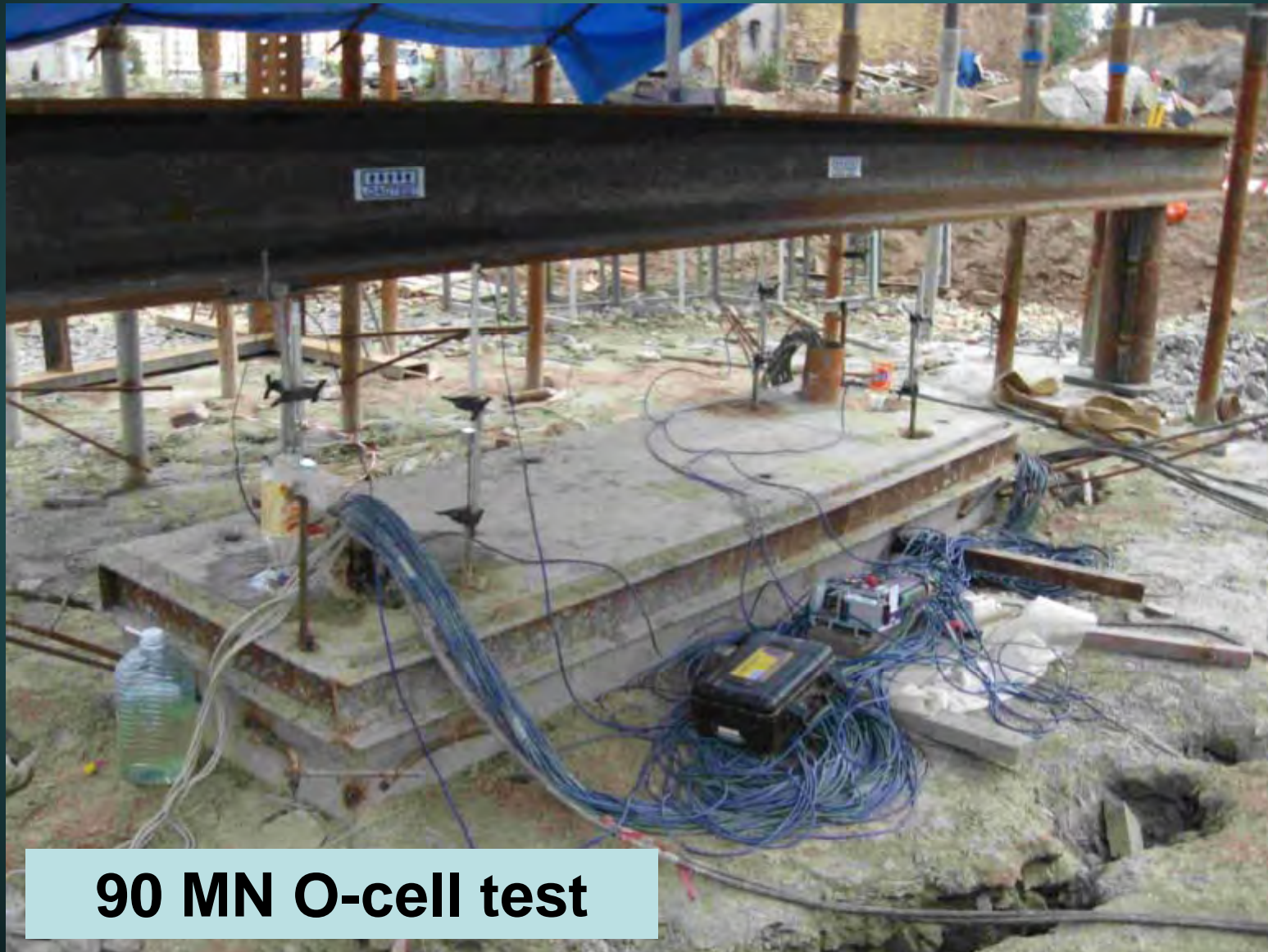

90 MN O-cell test

O-cell Split Lateral Test



Two 16 MN (3600 kip) O-cells test lateral stiffness of the Cooper Marl (19-21 m depth) on a 2.4 m (8') pile



27MN (6000 kip) O-cell used to test a 1.5 m (5') long by 1.2 m (4') diameter rock socket

O-cell Split Lateral Test Assembly





O-cell Split Lateral Test Result

Split Shaft Lateral O-cell™ Load-Movement Curves

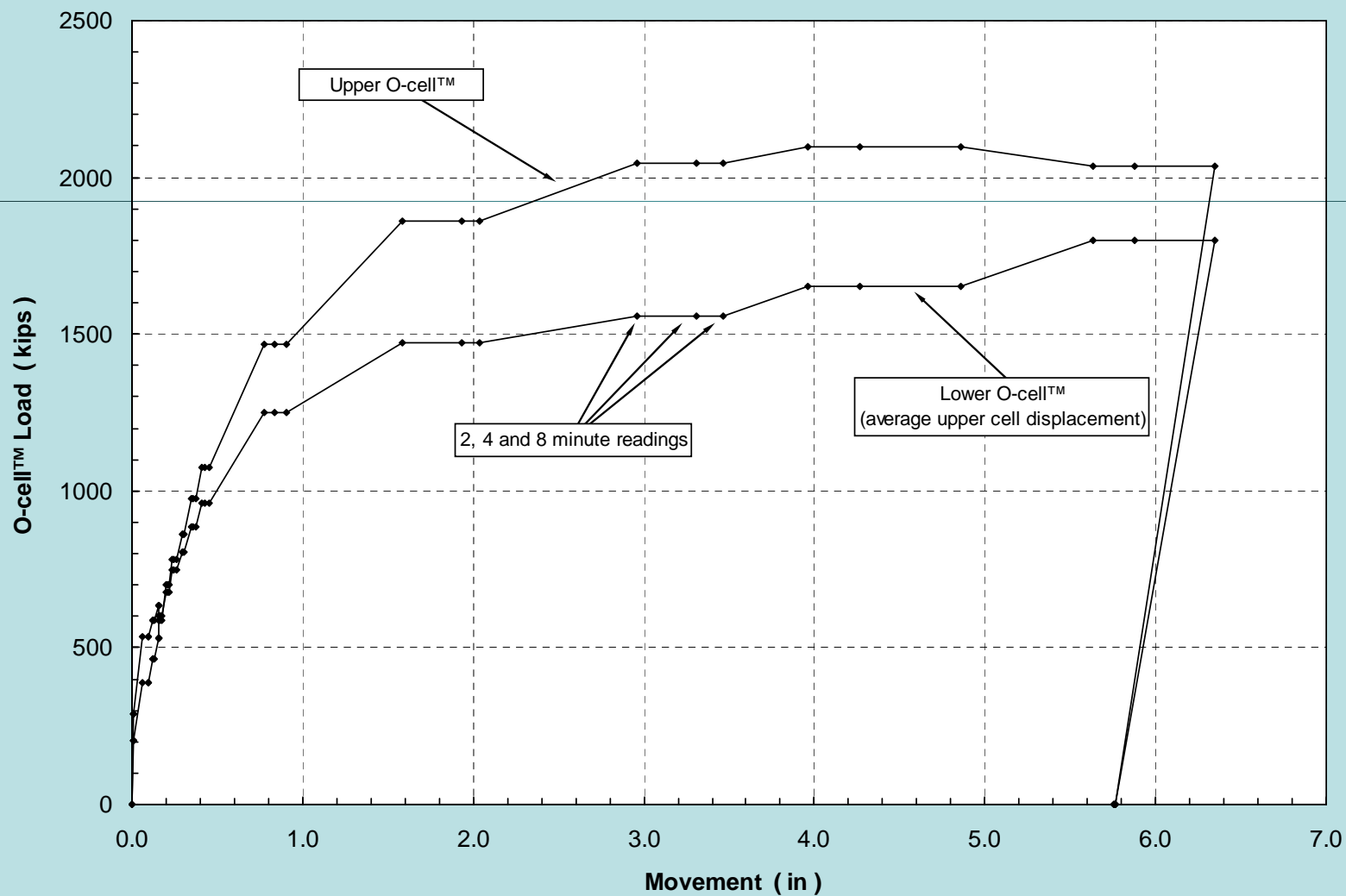



Conclusions

- **Deep foundation design generally conservative due to uncertainty**
- **Reduce project cost through more efficient design that reduces uncertainty**
- **Use a portion of the cost savings to fund the testing needed for more efficient design**
- **Many good tools available for testing deep foundations – use them**



Thank You

www.fugro.com
www.loadtest.com



“Construction and Performance of a Cellular Cofferdam in Northern Ontario”

Tom Sabourin, PE

Kiewit Engineering Company

Tom is a graduate of the University of Alberta, Canada, where he received both a Bachelor of Science in Civil Engineering (82) and Master of Engineering in Geotechnical (89). Tom worked as a geotechnical consultant in western Canada for 20 years prior to joining Kiewit in 2002. Tom has extensive experience in deep foundations, slope stability, cofferdam design, and rock slope engineering. Tom is the chief technical designer and engineer of record on the Lower Mattagami cofferdams.

John Puls, EI

Kiewit Engineering Company

John is a graduate of Iowa State University where he received a Bachelor's of Science in Civil Engineering and a Master's of Science in Civil Engineering with a specialization in Geotechnical Engineering. He joined Kiewit in 2009 as a design engineer for Kiewit Engineering Company based in Omaha. His project experience includes design of temporary structures including cofferdams, support of excavation systems, and deep foundations for projects across the United States and Canada. In 2011, John was selected to serve as the on-site designer's representative for the construction of the Harmon cellular cofferdam in northern Ontario. In this role, he worked as a part of the construction team to identify, develop, and implement design changes as a result of the challenging construction environment.



Note: the notes for this presentation was not made available by the speaker. Anyone who has questions regarding the presentation can contact Mr. John Puls at 402-342-2052 or e-mail to John.Puls@kiewit.com.

“2011 Flood Fight at Eppley Airfield”

Brian Linnan, PE

URS Corporation

Mr. Linnan has a BS in Civil Engineering and a MS in geotechnical engineering, both from Iowa State University. He has worked for URS Corporation in their Kansas City area office for 25 years and worked for Patzig Testing Laboratories in Des Moines for four years prior to joining URS. His primary areas of practice include dam and levee projects, landslide investigations and repairs, landfill design, and foundation investigations.

Francke Walberg, PE

URS Corporation

Mr. Walberg has a BS in Civil Engineering from Iowa State University and an MS in Geotechnical Engineering from the University of California at Berkeley. He worked for the U.S. Army Corps of Engineers for 35 years. Mr. Walberg retired from the Corps in 2003 and is currently a senior geotechnical specialist in the URS Overland Park, KS Office. He was Chief of the Geotechnical Branch in the Kansas City District where he was responsible for geotechnical aspects of all District programs. Since 2004, Mr. Walberg has been working as a consulting engineer on a variety of dam and levee projects including the design for several dam projects in the Midwest, and levee projects in the Midwest, Texas, and California. He has also served on consulting boards for seepage and seismic rehabilitation of Fern Ridge and Tuttle Creek Dams.



EPPLEY AIRFIELD

FLOOD FIGHTING INITIATIVE OVERVIEW



OMA

Part 1 – Overview of the flood and OAA's Response

Part 2 – Geotechnical Aspects of the Flood Fight



Part 1 – The Flood



Missouri River Basin

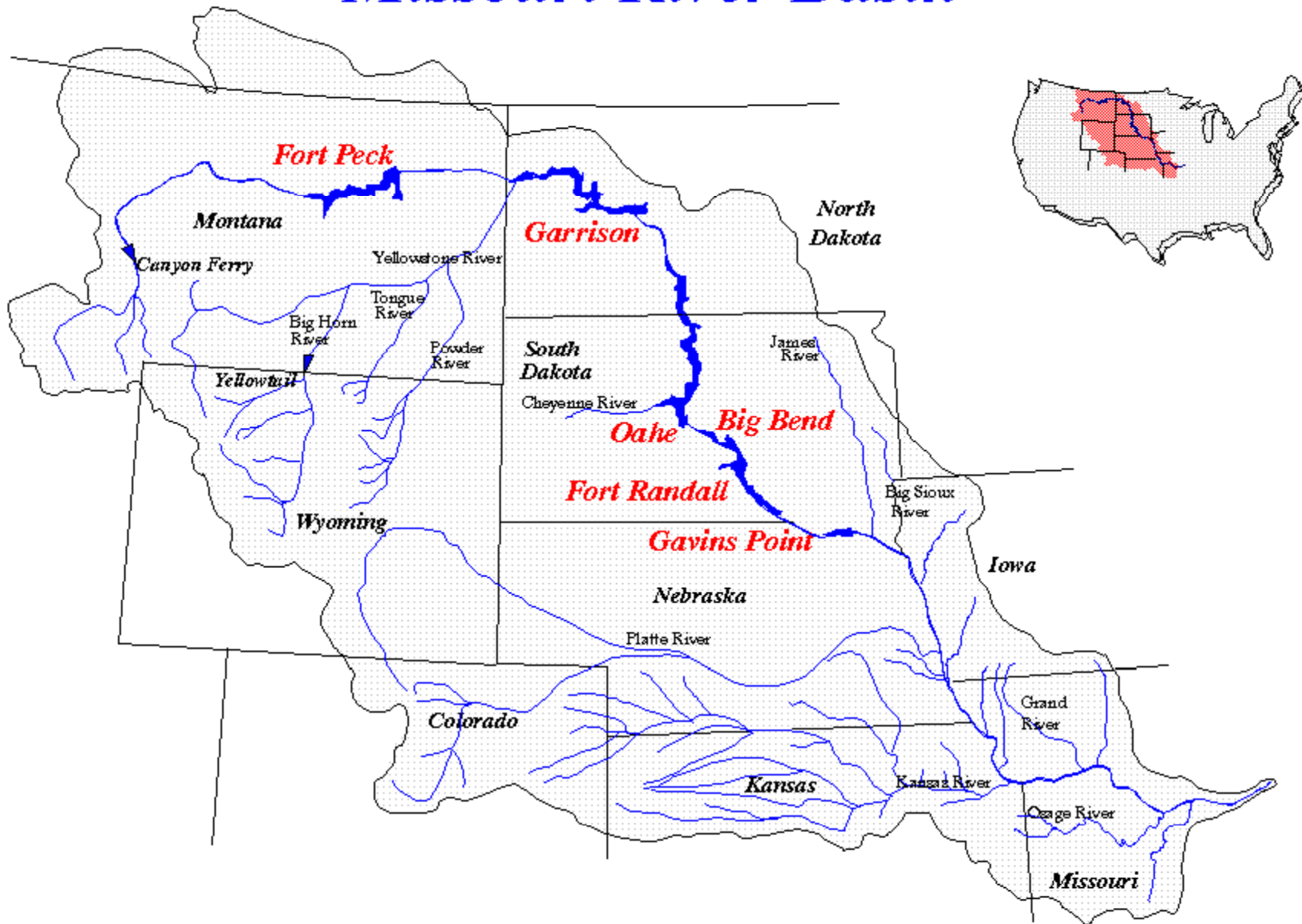

Storage Capacity of Corps Reservoirs

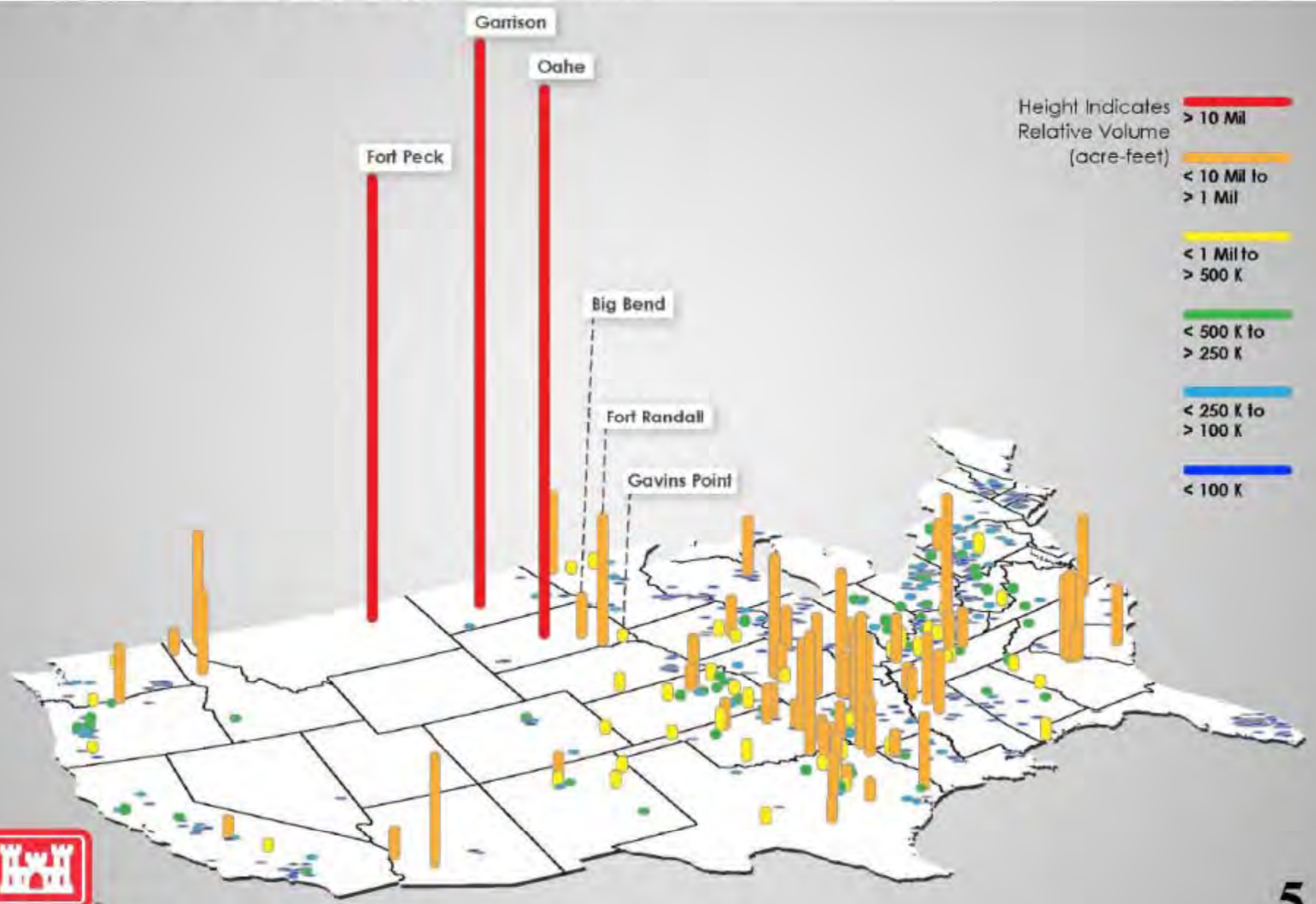

US Army Corps of Engineers
BUILDING STRONG

2011 Flood

- Heavy plains and near record mountain snowpack
- May rains 2-4X normal in upper basin
- 160000 cfs releases from Gavins Point - 14 June to 1 August

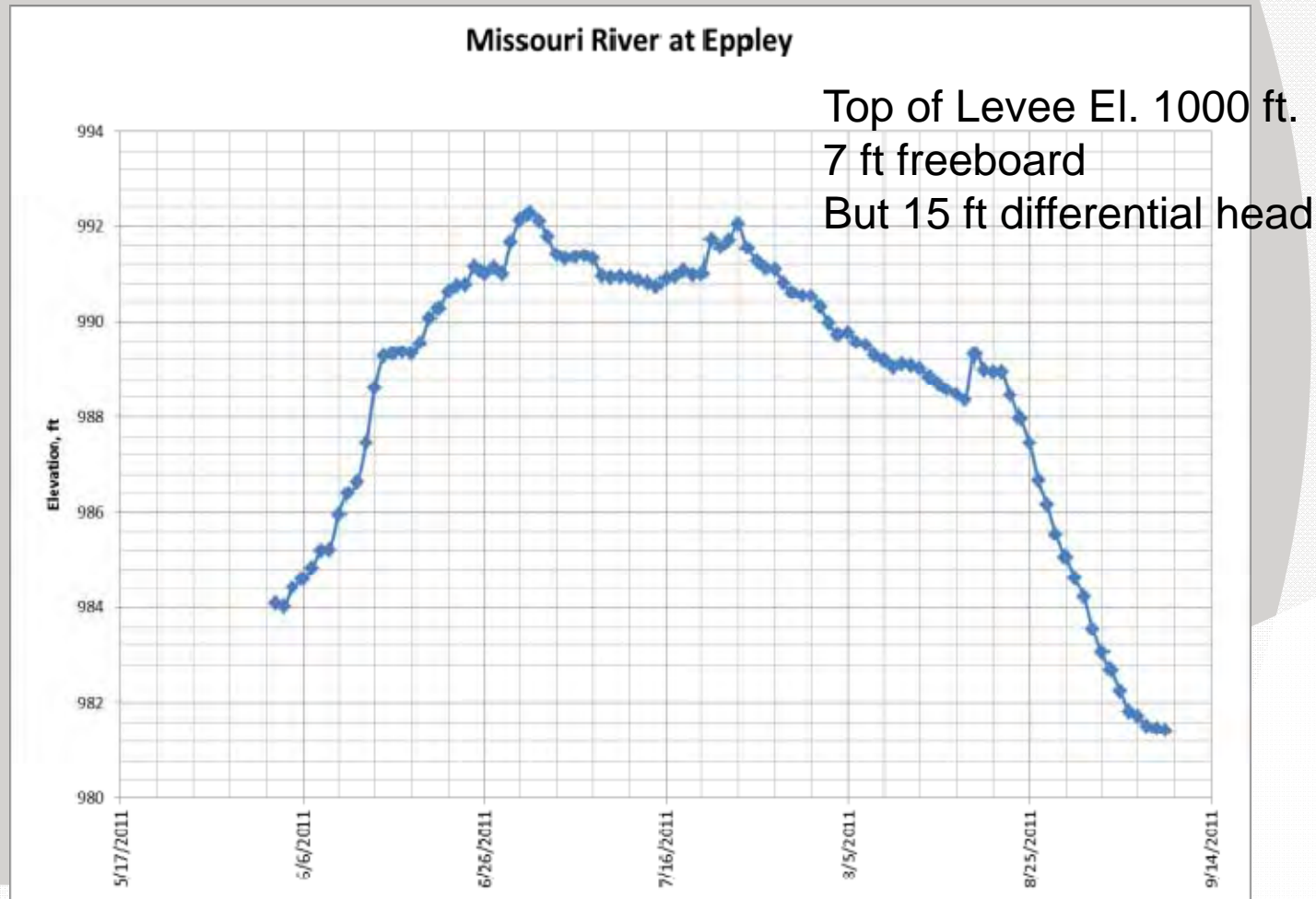

Eppley Airport: June 2011



Part 1 – OAA Response

- Team and Mission

Formation of a Team

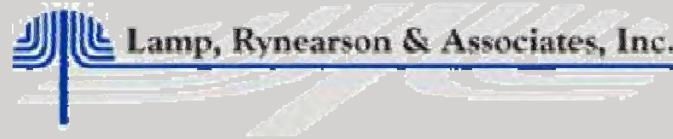

Objective

- Protect Airport Assets
- Maintain Normal,
Uninterrupted Air Operations



Part 1 – Levee Assessment

Omaha North Levee 1952

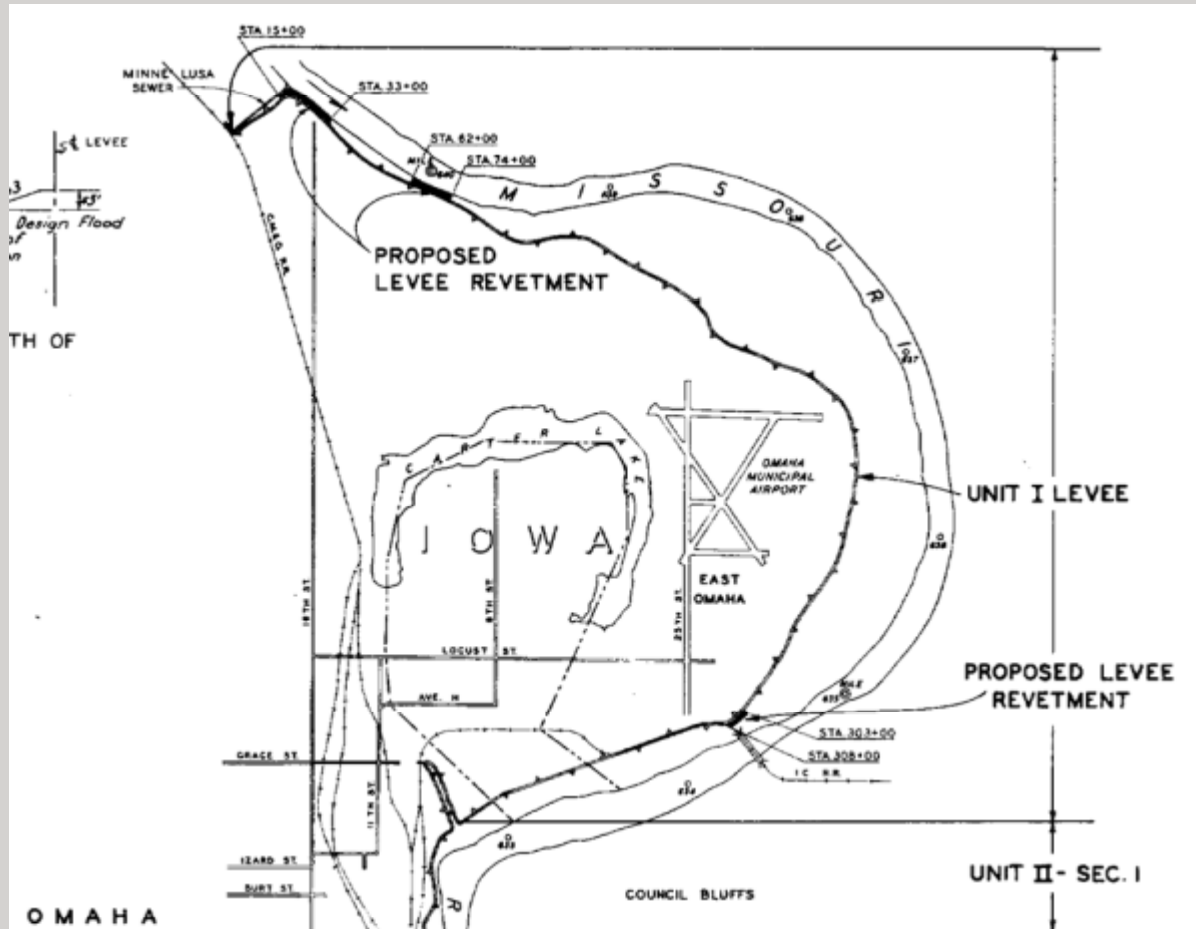

Levee Raise (approx. 1948)

Included installation of relief wells,
collector system

Documentation:

- 1940's DPR's
- O&M Manual
- But no as-builts

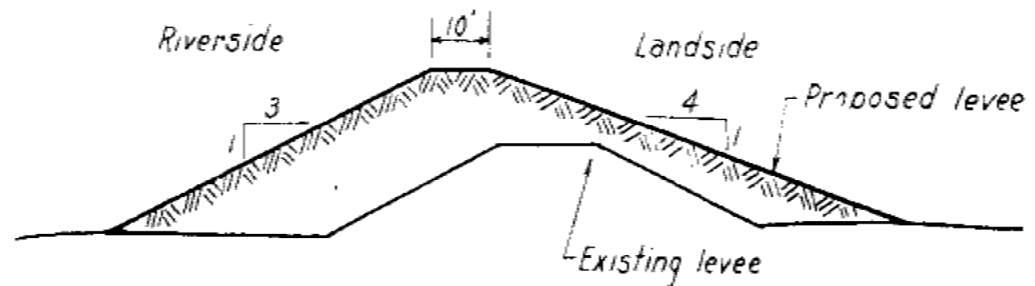

TYPICAL EMBANKMENT SECTION
STA. (0+79) TO STA. 391+83.73

NOTE:

The relative position of the
axes of the new and existing levee
varies.

1974 Airport Expansion

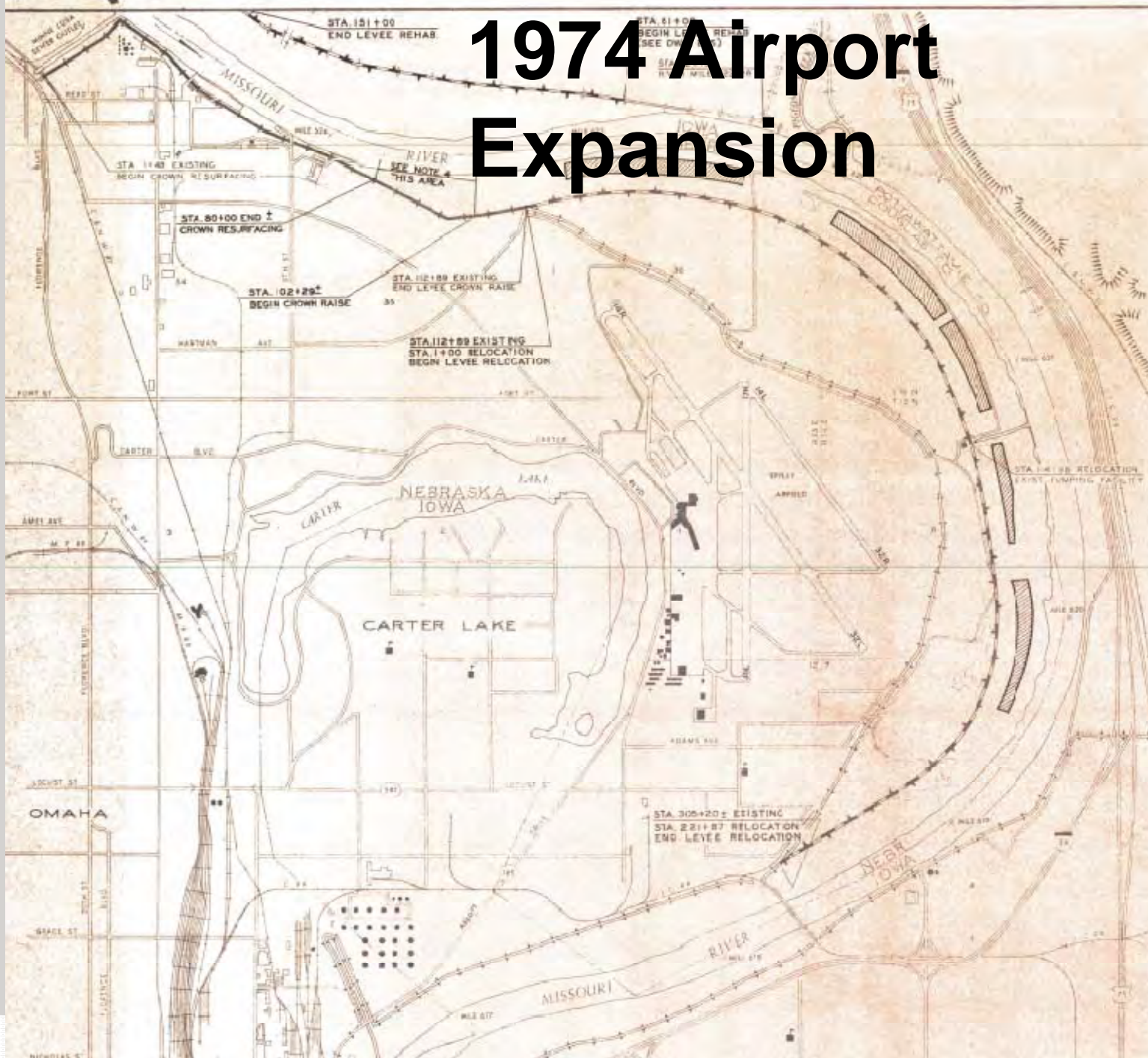

Typical Section 1974 Levee

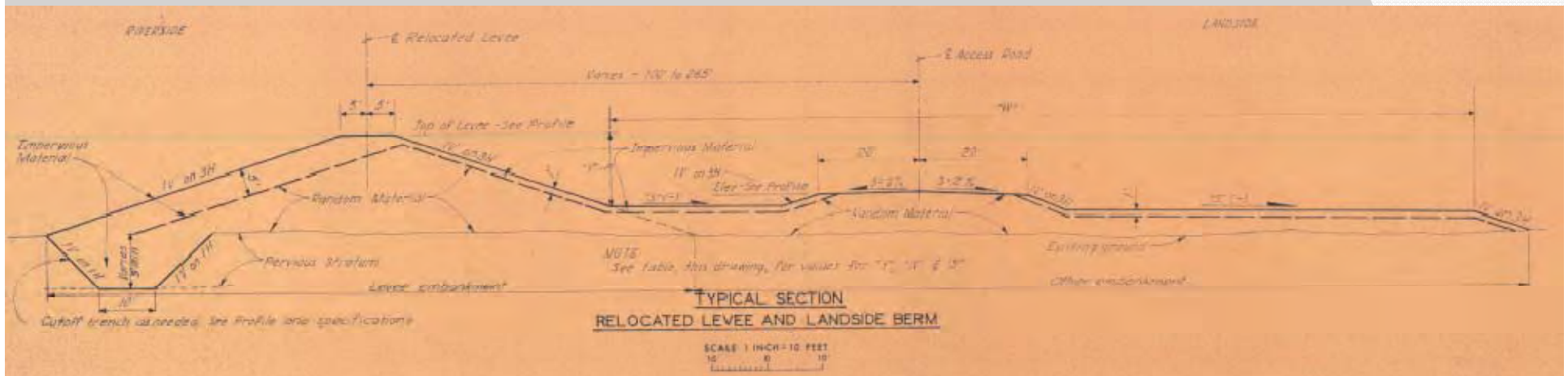

TABLE

REACH STATION TO STATION	Y ¹ IN FEET	W ² IN FEET	S ³ 1:1
10+00 [*] - 28+00	14	400	IV on 100 H
28+00 - 43+00	13	500	IV on 100 H
43+00 - 68+00	14	320	IV on 50 H
68+00 - 77+00	14	200	IV on 100 H
77+00 - 86+00	14	400	IV on 100 H
86+00 - 118+00	13	450	IV on 100 H
118+00 - 166+00	13	250	IV on 100 H
166+00 - 183+00	12	300	IV on 100 H
183+00 - 195+00	10	300	IV on 100 H
195+00 - 209+00	10	250	IV on 100 H
** 209+00 - 221+80 [†]	10	Varies	IV on 125 H

* Transition from Sta. 3+00 to Sta. 10+00 (Existing levee to Full Relocation Section)
 ** Dependent on Disposition of Railroad Spur and Existing Well System

- Documentation:
- Record drawings
 - But no design document

Initial Inspection

Airport levee



North Levee



Levee Wells and Piezometers
(North of Eppley Airport)



Legend

Wells and Piezometers

STRUCTURE

- + Piezometer
- Well

South Levee

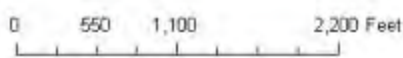

- Legend**
Wells and Piezometers
STRUCTURE
+ Piezometer
• Well

Historical Performance

- 1952 flood tested levee system
 - Old portions, North and south of airport
 - 1952 River level within a few feet of levee crest
- 1974 portion untested
- 1952 Distress
 - Had to pump relief wells some areas
 - Replaced north collector system and installed additional wells after 1952 flood



East Pump Station: discharge outlet design

block dimensions = 2x3x6 Ft

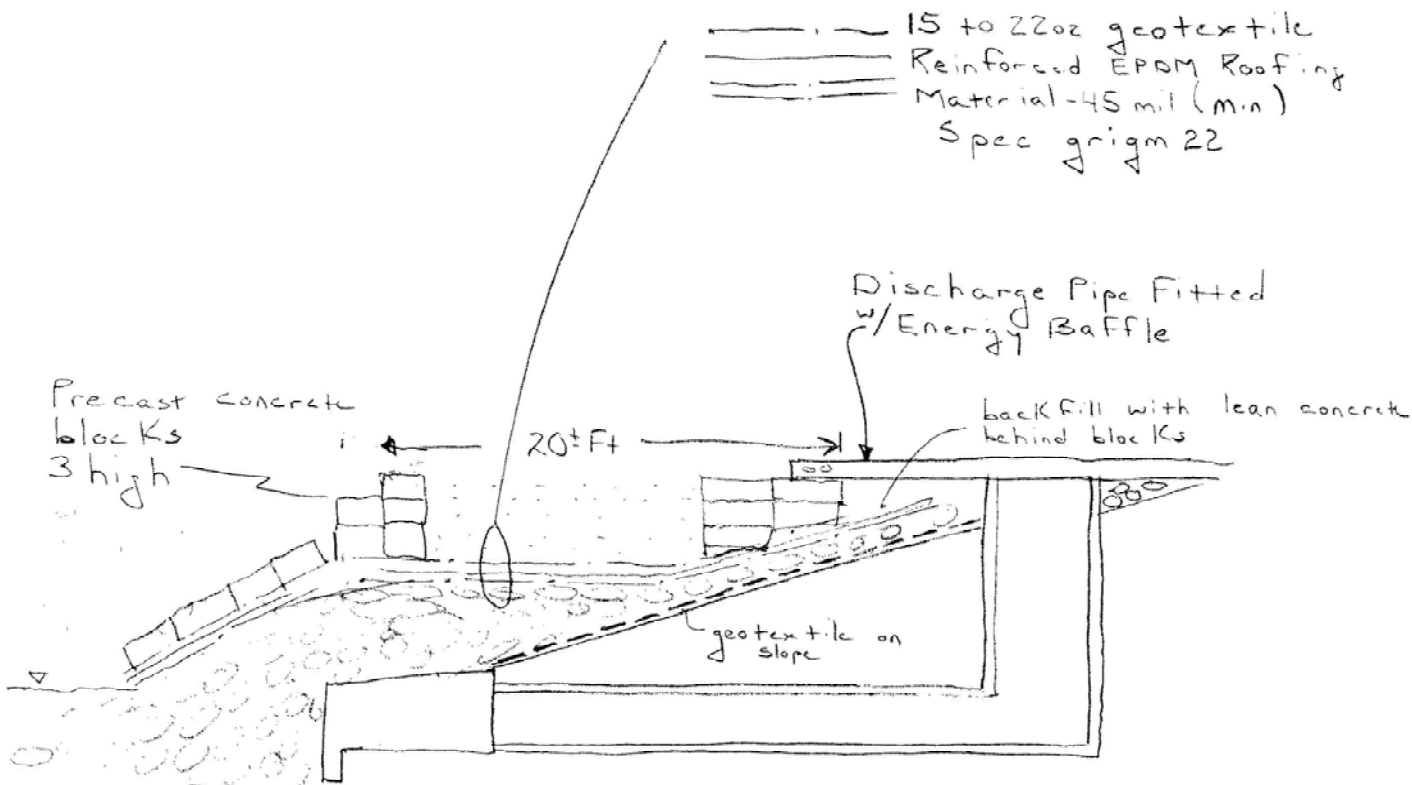

EPDM Suppliers:

Carlisle

Firestone

Randy Ober (717) 245-7000 ext 7041

Ober. syntec, carlisle. com

Paul Oliveira

Oliveira-Paul@firestonebp.com

URS

Job Epley Airfield

Project No. _____

Description Levee Reinforcement at Pump Station Discharge

Computed by BOL

Checked by Jew

Page _____ of _____
 Sheet 1 of 1
 Date 16 June 2011
 Date 16 June 2011

Reference

East Storm Water Pump Station



East Pump Station Detail



Part 1 – Response Plans

- ⦿ Preparedness Plan (readiness)
- ⦿ Surveillance Plan (prioritize response)
- ⦿ Emergency Response Plan

Surveillance Plan

Key objectives:

- Establish initial baseline conditions
- Daily surveillance tracks changes and rates of change
- Accommodate numerous distress incidents
- Prioritize response-problem assessment chart
- Surveillance Log convenient for field personnel and managers

Monitoring



Levee Problem Assessment Chart Version 2.2

4-Jul-11

Levee and Toe Area

1. Underseepage: near levee toe (within 50 ft levee toe)

Problem	Category	Action	Data to be Reported	Remarks
A – wet soft area, no or little standing water, water is clear.	Non-Emergency	Normal Monitoring	Completely describe conditions and location (size of seepage area, time, quantity of surface water)	
B- Standing water, evidence of limited localized seepage, water clear, presence of oily sheen, ground firm	Non-Emergency	Normal Monitoring	Same as above	
C- Soft area, standing water, seepage water clear, no boils	Non-Emergency	Normal Monitoring	Same as above, plus rate of flow	
D – soft area, ground somewhat unstable, significant seepage, minor pin or small boils, flowing clear, minor amount of material associated with boil	Non-Emergency	Monitor, twice daily	Same as above, plus rate of flow	
E-limited soft area, small boils, flow clear, but fan of material has formed, or small conical deposit of sand has formed, rate of flow not increasing	Non-failure emergency	Closely monitor, check at 4 hr intervals during daylight, last check early evening before dark	Same as above	If higher river stage is expected take measures to establish construction access, and construct weighted filter (see procedure: sand over geogrid, if required for trafficability, filter cloth, 6 to 8-inch minus crushed stone). Consider temporary sand bag dike if construction access difficult or lengthy.

City of Omaha, LRA, & Thiele - Observation Log

Observation Range:

From Levee Mile N13.4 to Levee Mile 6.1 (From Pershing Street to Abbot Drive)

Event Area	Event No.	Levee Mile (Army Corp)	Location Description	Event Type	Highest Class of Distress	Current Class	Est. flow (gpm)	Comments
LRA	25	8.07		Seepage	D	D		<p>7/6 Discovered initial class C Seepage event. Seepage on both sides of Lindbergh near LM 8.1. 25 - 50' E of Culvert crossing.</p> <p>7/7 Light seepage. Area remains firm. Occasional bubbling. More presence of iron on North side than South side.</p> <p>7/12 Small boil discovered North side of road 50' East of light pole. Clear, no plume of material. Pink flag at location. Upgraded to Class D event per Nick (Kiewit).</p> <p>7/14 Another small boil discovered 20' East of light pole on North side of road. Clear, no plume of material. Pink flag at the location.</p> <p>7/19 Bilster discovered and popped total blisters that have been found is 4.</p>
LRA OMA	18	N12.6	Penzine. Event spans N LM 12.5-12.7		F	D		<p>6/30 Water seeping out the base of the levee. Initial Class E event.</p> <p>7/3 Saturation line approx. 2 ft horizontally up levee.</p> <p>7/4 Very soft up side of levee.</p> <p>7/7 Cloudy water South of Penzine property near Flint Hill truck scale. Class F event.</p> <p>7/8 Corps contractor mobilizing, clearing, and staking limits. a.m. - Sand in place.</p> <p>7/9 Blanket complete except beneath transmission line tower. Surveillance continues. Downgrade to class D per URS.</p> <p>7/11 Seepage berm construction complete. Toe of levee soft and saturated West of USACE's seepage berm to property line of International Paper.</p> <p>7/12 Seepage berm not constructed on West end of property behind metal sheds. Standing water and saturated ground at toe of levee behind the metal sheds, West of new seepage berm.</p> <p>7/18 Dryline on landside of levee marked in field. Water main break on Read Street West of Penzine. MUD and OPPD onsite to repair.</p>
LRA OMA	20	N12.5	Flint Resources. Event spans N LM 12.4-12.5 Near Tank 2		F	D		<p>6/25 Pin boils near tanks in and along drainage ditch, portion of crushed rock road near Tank 1 shows signs of heave distress, cracking. City and Corps notified. Class E.</p> <p>6/30 National Guard flags identify pin boils, very little flow, portion of crushed rock road shows signs of heave distress, cracking.</p> <p>7/2 Soft spongy area has expanded.</p> <p>7/3 Cracks in crushed rock area, oily sheen.</p> <p>7/4 Boils w/ sediment near metal tanks.</p> <p>7/5 Numerous boils moving material. Expanding in area. Extremely soft, cannot traverse on foot. Evidence of heave distress, cracking, and spongy ground. Class F event.</p> <p>Corps contractor mobilizing, clearing, and staking limits.</p> <p>7/8 a.m. - corp contractor constructing seepage blanket.</p> <p>7/9 Blanket completed. Small size boils in drainage channel south of south tank.</p> <p>7/10 Surveillance continues. Downgrade to class D per URS.</p> <p>7/14 05:00 - Two new small boils north of Tank 1 at Flint Hills near edge of treated area, moving little or no material.</p> <p>7/17 Very soft ground around the perimeter of tanks 1 and 2 due to non placement of perforated pipe. Water not draining correctly.</p> <p>7/18 Numerous boils moving material on sides of tanks with unstable ground. Water seeping out of seepage berm. Appears to be clear.</p>

Presentation

Part 1 – Overview of the flood and OAA's Response

Part 2 – Geotechnical Aspects of the Flood Fight

Part 2 – Perimeter Pumped Wells



Inspection of Storm Water Pipes with TV Cameras



Boils and Sinkholes



Perimeter dewatering system

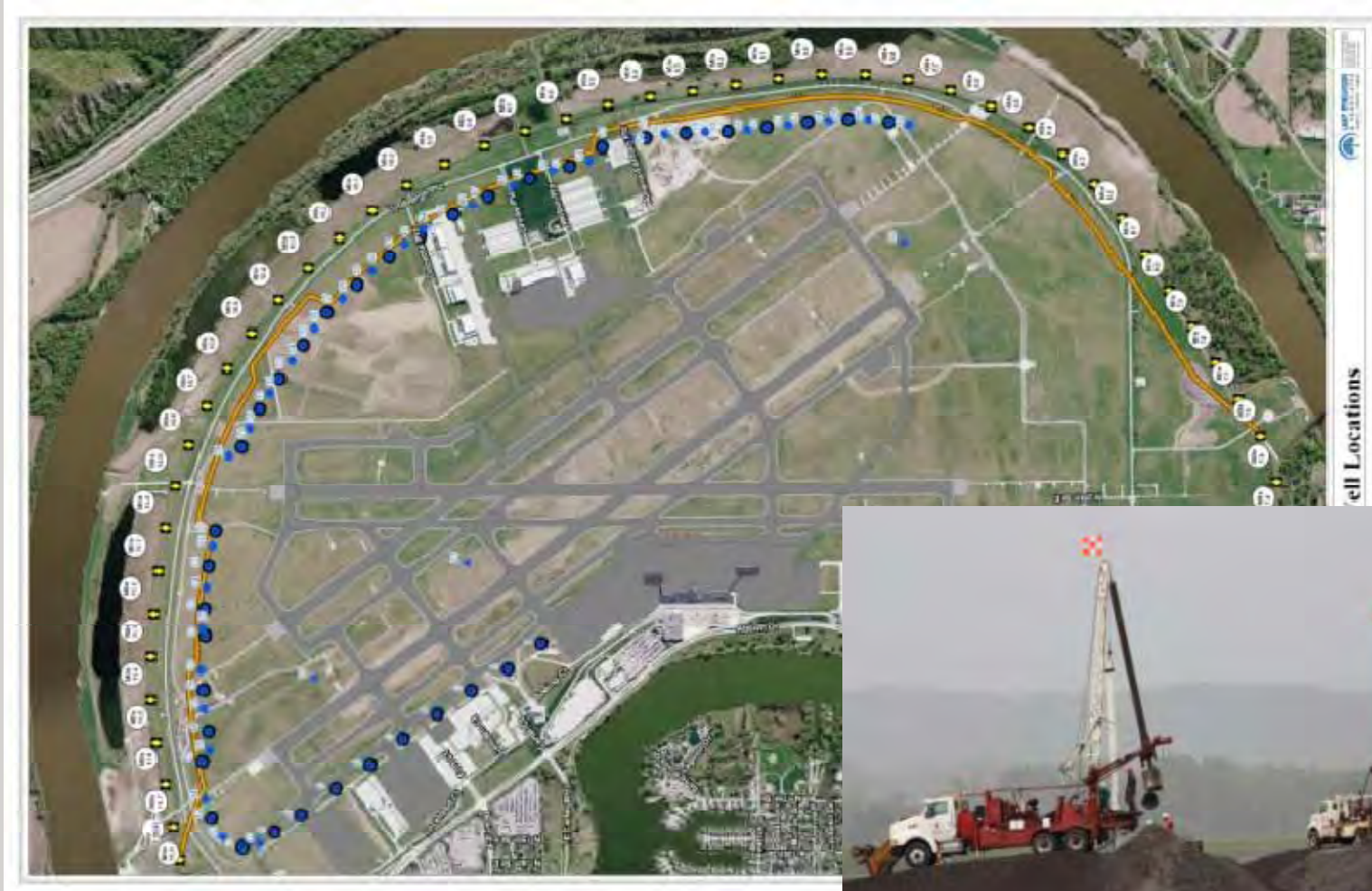

Completed dewatering system



Daily Instrumentation Report

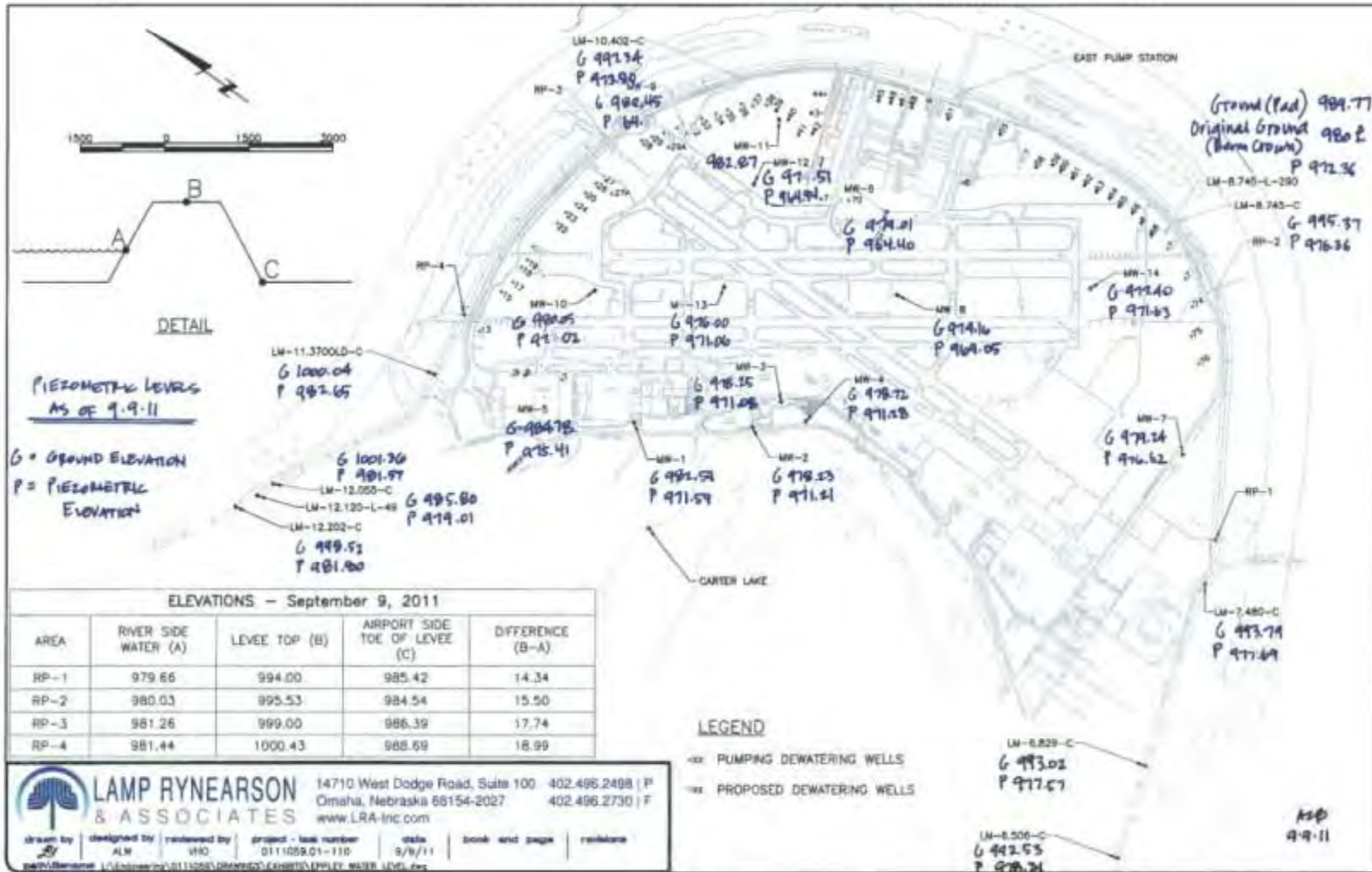

Daily Plots

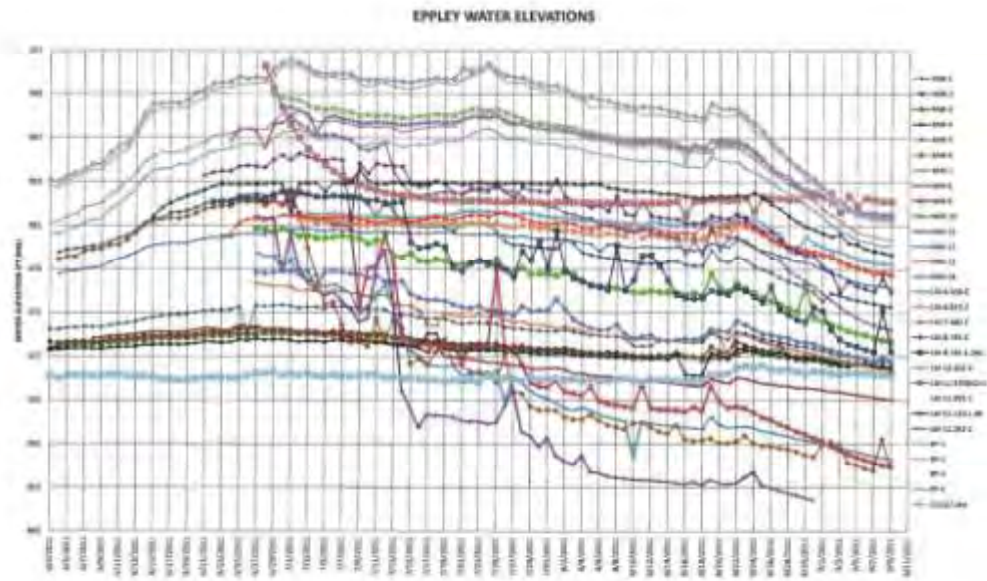
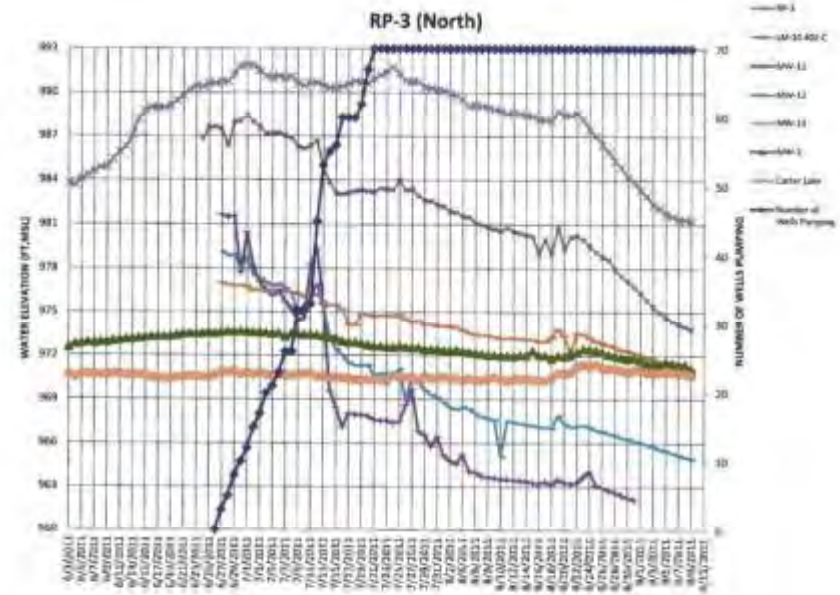

Part 2 – Response to levee under seepage





Response to sand boils



Typical “off-the-shelf” design

URS

Job Eppley 2011 Flood Fight

Project No. 16S30781

Page 1 of 1

Description Weighted Filter

Computed by bdl

Sheet of

Date 22 June 2011

Checked by zew

Date 22 June 2011

Reference

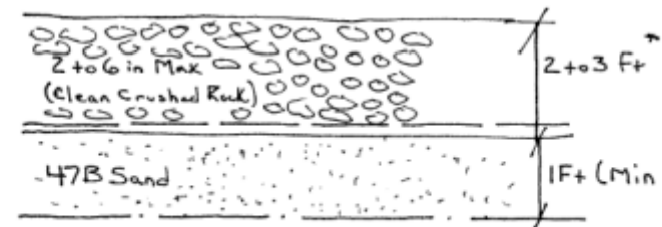

Legend:

- — Tensar TX-160 geogrid
- — Woven geotextile MiraFi FW402

* Initial thickness of rock cover to be established by observation of the area to be blanketed. Observations are needed on an on-going basis to monitor the effectiveness of the blanket. Placement of additional crushed rock may be necessary if exit gradients increase.

Existing Relief Well Rehabilitation

- ⦿ Clean by air lift
- ⦿ Pump at about 100 gpm for draw down of about 5-10 ft
- ⦿ Test for sand
 - If <5ppm, pump well
 - If >5 ppm, install liner prior to pumping

North Levee: Lindsay



North Levee: Lindsay



North Levee: International Paper



North Levee: International Paper



North Levee: International Paper



North Levee: International Paper



Eppley Airport Field Missouri River High Water 2011 Levee Mile 8.75



Analyzed: AZB
Checked: DN

River Stage 988.4 - Existing/Calibration

Name: Levee (1e-5 cm/s) Model: Saturated Only K-Sat: 3.3e-007 ft/sec Volumetric Water Content: 0.4 ft³/ft³ Mv: 0 /psf K-Ratio: 1 K-Direction: 0 °
 Name: Seepage Berm (1e-3 cm/s) Model: Saturated Only K-Sat: 3.3e-005 ft/sec Volumetric Water Content: 0.4 ft³/ft³ Mv: 0 /psf K-Ratio: 1 K-Direction: 0 °
 Name: Assumed Silt Blanket (1e-4 cm/s) Model: Saturated Only K-Sat: 3.3e-006 ft/sec Volumetric Water Content: 0.5 ft³/ft³ Mv: 0 /psf K-Ratio: 0.25 K-Direction: 0 °
 Name: Upper Aquifer (1e-2 cm/s) Model: Saturated Only K-Sat: 0.00033 ft/sec Volumetric Water Content: 0.5 ft³/ft³ Mv: 0 /psf K-Ratio: 0.25 K-Direction: 0 °
 Name: Lower Aquifer (1e-1 cm/s) Model: Saturated Only K-Sat: 0.0033 ft/sec Volumetric Water Content: 0.4 ft³/ft³ Mv: 0 /psf K-Ratio: 0.5 K-Direction: 0 °

Scale: 1 Vertical:10 Horizontal

Total Head Contours

Gradient Calculation

	A	B	C	D
Total Head - Top	= 984.0	982.0	976.0	
Total Head - Bottom	= 984.9	983.8	981.8	
Elevation - Top	= 984.0	982.0	976.0	
Elevation - Bottom	= 980.0	977.9	974.0	
Gradient, I	= 0.2	0.4	2.9	

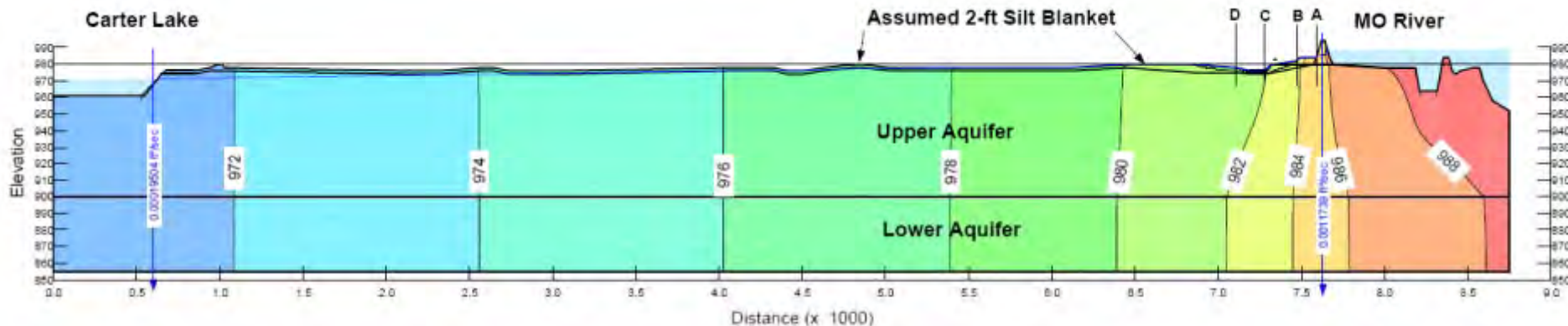

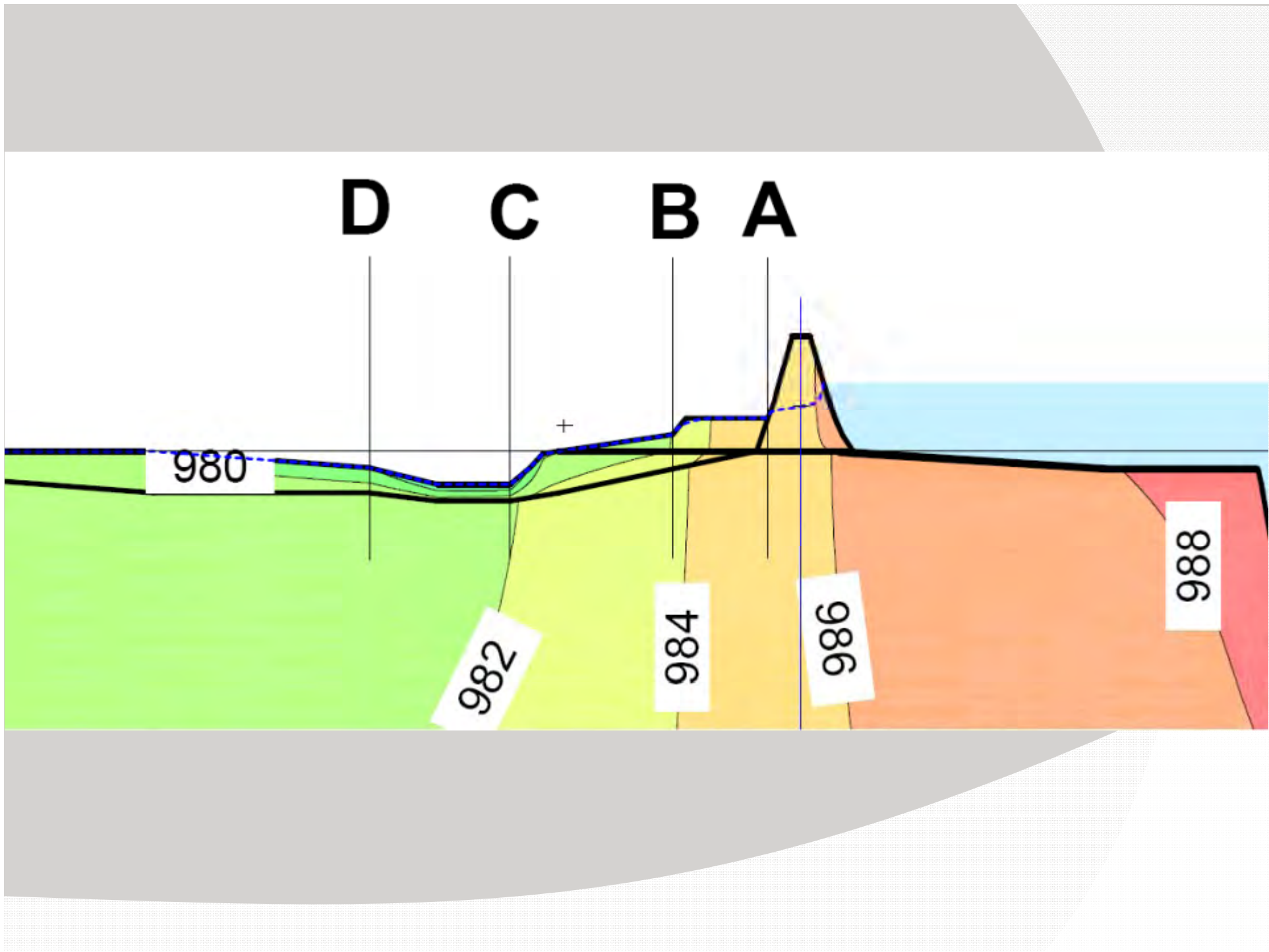

**“Landslide Impacts and Repairs in Eastern Ohio
Due to Hurricane-Related Storms”**

Jim Sheahan, PE

HDR Engineering, Inc
Vice President and National Director of Geotechnical Engineering

During his 43 year career, 38 of which have been with HDR, he has been responsible for the preparation, oversight and technical review of geotechnical investigations for transportation projects at sites throughout the US and in several foreign countries. He is an active member of the TRB (Transportation Research Board), serving on several Technical Committees related to structures and highway activities, is a member of the Deep Foundations Institute (DFI) Technical Advisory Committee (TAC) and has been a member of FHWA ACTT (Accelerated Construction Technology Transfer) Review Teams on projects in several states. He is also experienced with alternate delivery methods (Design-Build, PPTA, etc.) used for project completion.

Landslide Impacts and Repairs in Eastern Ohio Due to Hurricane-Related Storms

February 17, 2012

Presented by
James M. Sheahan, P.E. - HDR

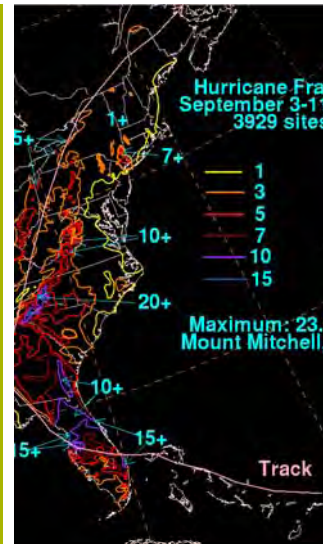

Hurricane Frances

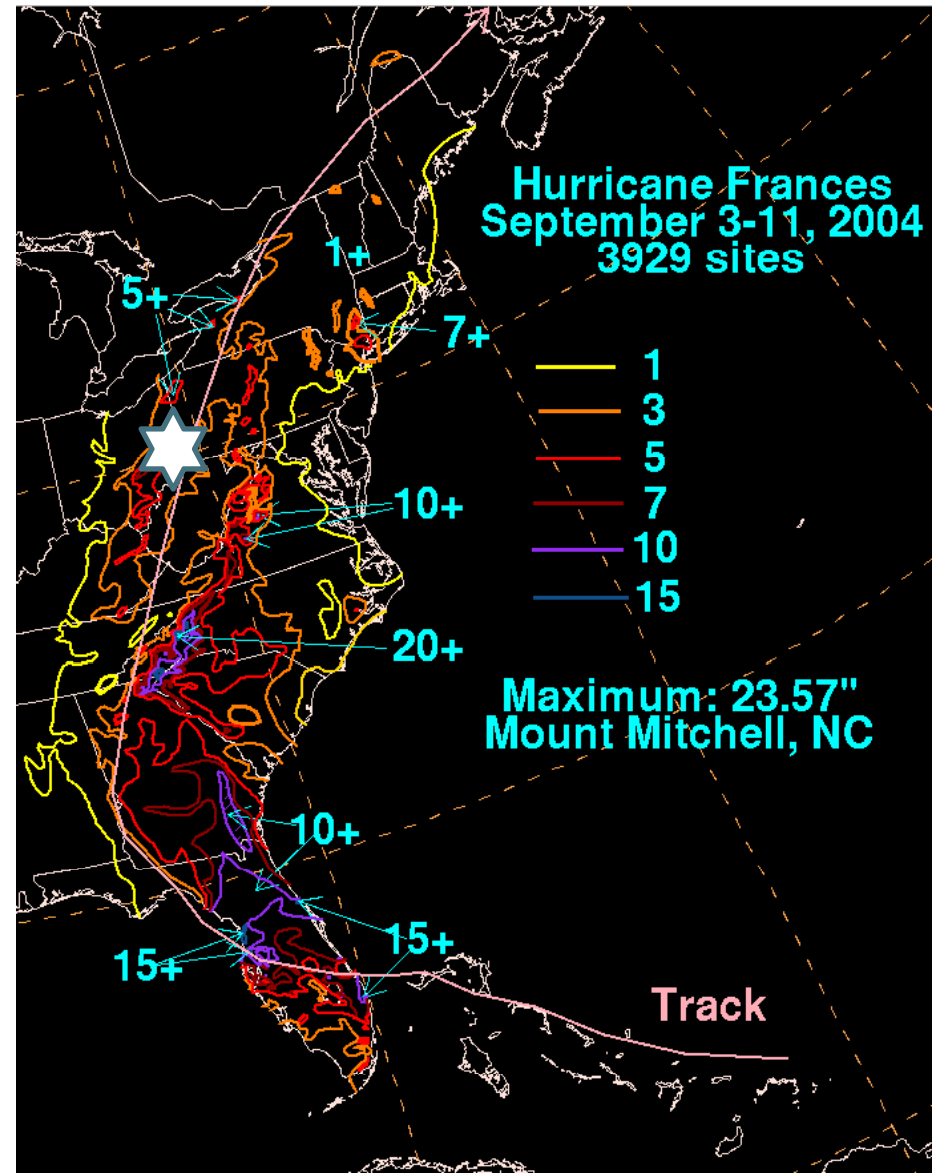
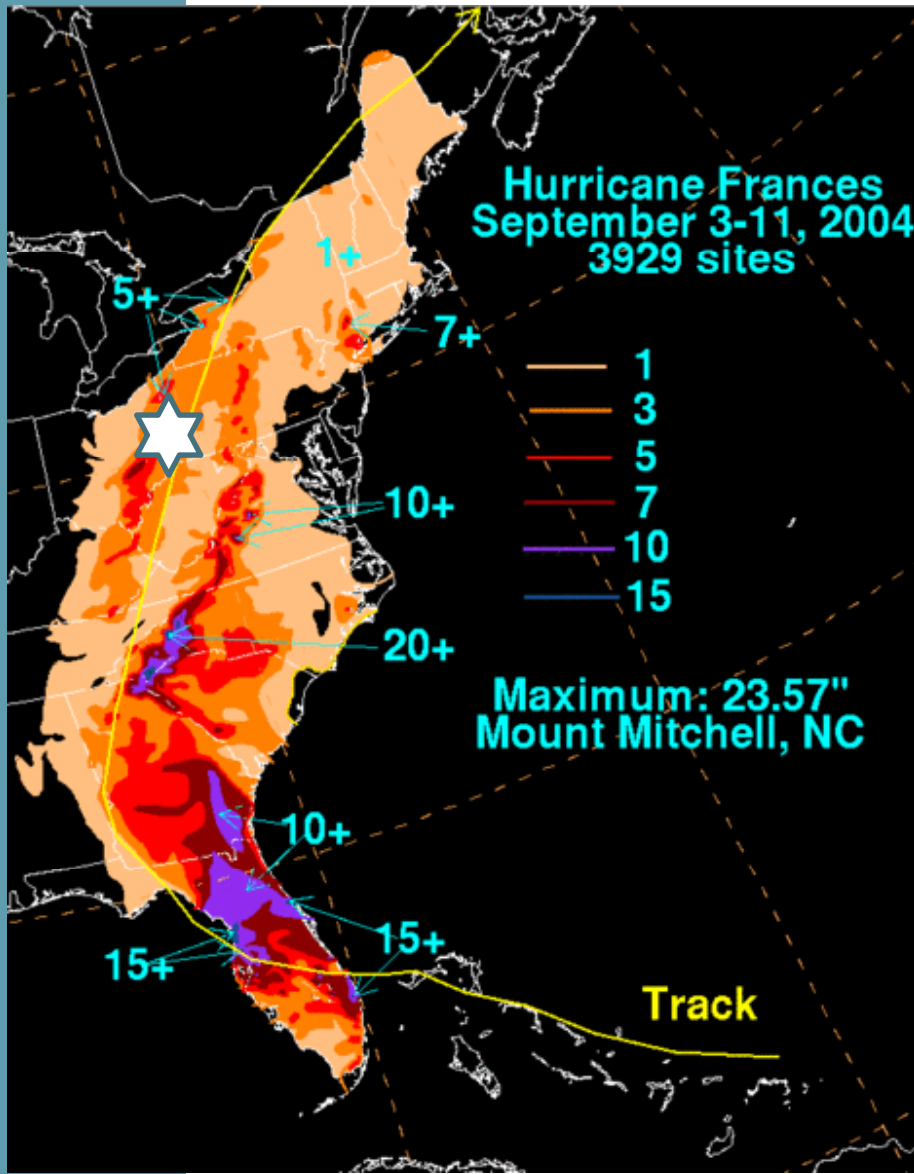

Hurricane Ivan

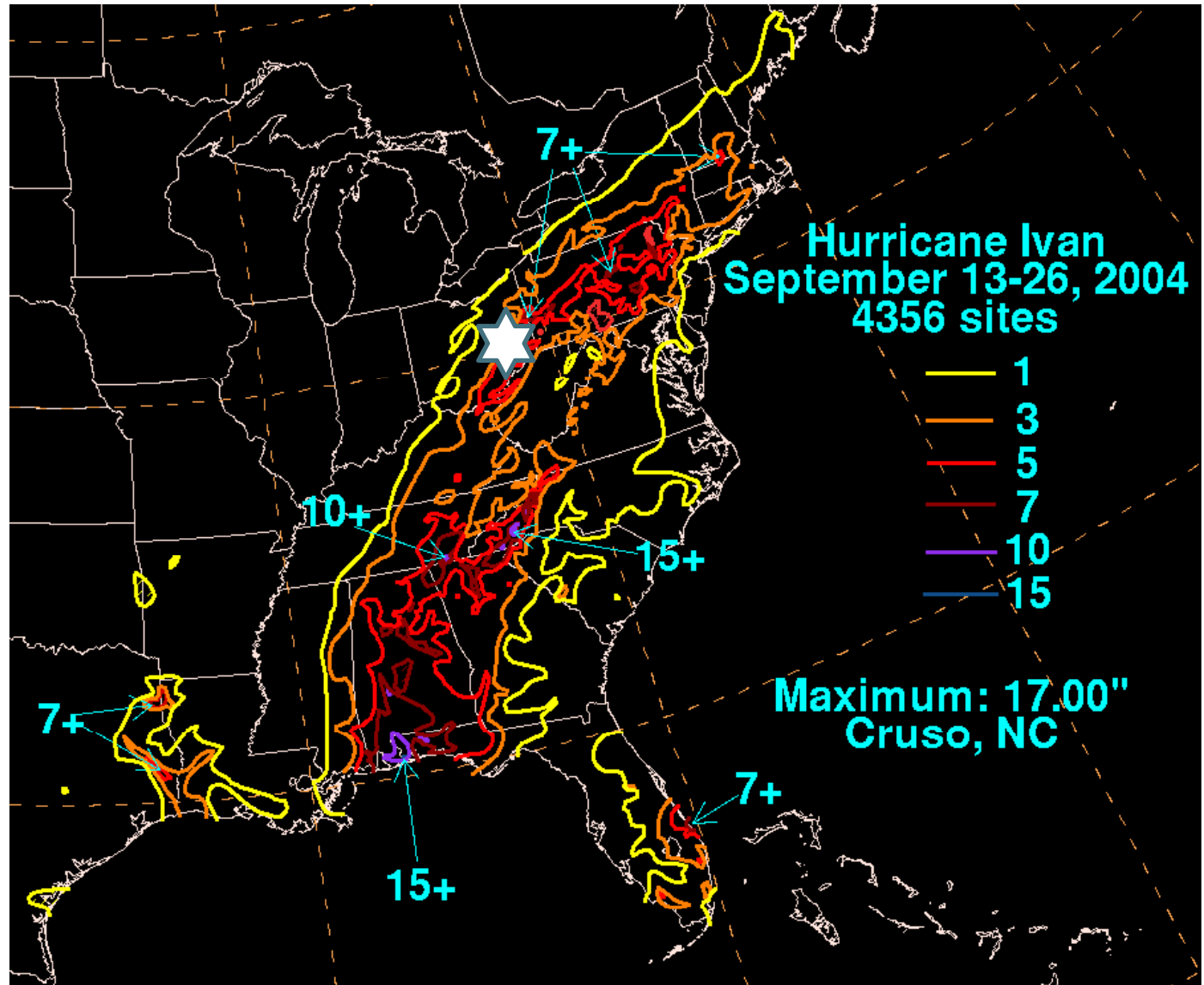

Ohio DOT Districts



2004 Rainfall Data (Ref: NOAA)

Division	Southeast [10]		Central Hills [5]		Northeast Hills [11]	
Month	Precip	Depart	Precip	Depart	Precip	Depart
Jan	4.36	+1.96	4.04	+1.94	4.72	+2.43
Feb	2.03	-0.47	1.44	-0.68	2.26	0.00
Mar	3.29	-0.22	3.52	+0.32	3.26	-0.15
Apr	4.36	+0.79	3.45	-0.01	4.49	+1.19
May	6.07	+1.94	8.58	+4.52	6.92	+2.99
Jun	4.29	+0.37	5.90	+2.04	6.54	+2.67
Jul	4.62	+0.16	4.66	+0.44	4.99	+0.74
Aug	4.29	+0.51	6.30	+2.55	6.26	+2.71
Sep	10.32	+7.26	3.63	+0.35	8.44	+5.35
Oct	2.93	+0.31	2.36	-0.07	3.14	+0.58
Nov	3.37	+0.14	3.37	+0.15	3.30	+0.15
Dec	2.89	-0.14	3.79	+0.97	3.38	+0.47
2004	52.82	+12.61	51.04	+12.52	57.60	+19.13

2004 Rainfall Data (Ref: NOAA)

Division	Cadiz		Steubenville	
Month	Precip	Depart	Precip	Depart
Aug	8.11	+3.96	6.41	+2.57
Sep	10.53	+7.32	10.61	+7.35

ODOT District 10/HDR GES Contract

Task Order	Project Designation
11-A, A1	BEL-70-22.58
11-B, B1, B2	BEL-149-0.8
11-C	JEF-213-14.10
11-D, D1	TUS-416-13.0
11-E	TUS-416-14.3
11-F	BEL-148-12.05
11-G, G1, G2	JEF-152-24.0
11-H	JEF-150-8.9
11-I	BEL-CR-10-9.93
11-J	BEL-CR-4-7.72
11-K	TUS-212-6.7
11-L	TUS-212-7.6

Ohio Map

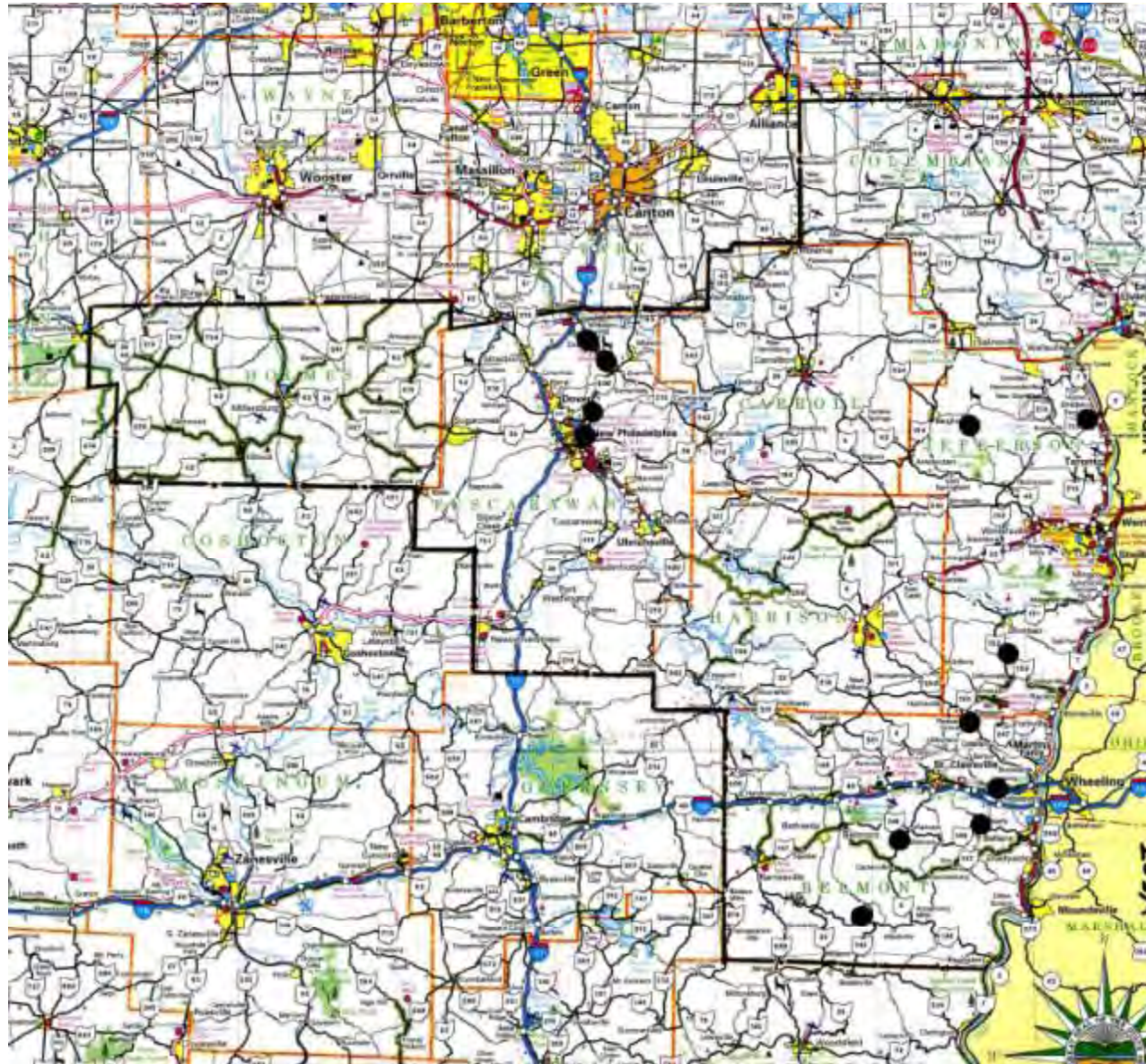

The Process - Engineering

- Field Meeting
- Scoping Memo
- Task Order Proposal (Possibly Staged)
- Office and Field Investigation
- Selection and Evaluation of Options
- Preliminary Estimates of Cost for Options
- Selection of Option
- Development of Construction Drawings
- Coordination During Design and Construction

**Ohio Department of Transportation
 VAR-District 11 General Engineering Services No. EM2005-1
 Scoping Memorandum
 Task Order 11-G**

PID NO	COUNTY	ROUTE	SLM
78724	JEF	152	24.0

FIELD OBSERVATIONS

Date of Visit – February 27, 2005

- Estimated length of distressed area 300 feet on reverse curve alignment and 6% profile grade.
- Grading condition in distressed area is in the embankment.
- Signs that movement has been an on-going in this area based on adjacent guide rail posts below existing posts, cross slope break and rock buttress fill against embankment slope.
- Natural topography downslope of distressed area. Is there lateral movement on bench or is bench moving toward stream?
- Rock fill along the downslope embankment of roadway indicates that drainage created its need and rock fill drains in the original construction. Drainage may be blocked.
- Settlement of pavement is evident. (Are there abandoned mines near the surface ?)
- Major crack on upper grade near parallel with the roadway has vertical and lateral displacement. Was embankment built on colluvium?

COMMENTS and KEY ISSUES

- Roadway may be located on colluvial mass moving downhill toward parallel small stream.
- Location (vertical) and lateral extent of movement not obvious during site visit, therefore further investigation needed to determine causes, zones of movement and possible repairs.
- Determine geology including coal measures.
- Take borings and, if time allows, install inclinometers to monitor movement over extended period.
- Develop repair scheme(s) based on borings and monitoring data.
- Possible repairs at this time include wall and/or removal and replacement with improved drainage.

PROPOSED SCOPE OF WORK (Work by HDR unless shown otherwise)		SCHEDULE	
		Begin	Complete
Item 1	Reconnaissance and Planning <ul style="list-style-type: none"> • Make site visit to observe conditions in and around distresses area • Prepare scoping memorandum to summarize initial observations • Review available existing information at District (e.g. construction plans, reconstruction/repair plans, aerial photos, borings, reports, etc.) • Review available geologic information • Review available mining information (thru ODNR and mining companies, if necessary). Includes locating site on USGS mapping. • Develop estimated scope of detailed investigation and report with repair alternates (Work Items 2-5) • Develop estimated scope to prepare construction plans for repair (Work Item 6) • Coordinate with Department 	2/27/05	3/18/05
		8/01/05	
			9/09/05
Item 2	Survey (Subcontract to ...) <ul style="list-style-type: none"> • Establish limits of distressed area on roadway centerline as marked by HDR. Tie information to centerline stations in construction plans, if possible. • Determine current property owners and property lines from DOT ROW ownership/easements from 100 ft. left of road centerline to 50 feet south of stream within area of study. • Determine utility easements and ownership within the area of study. • Locate significant features including drainage, seepage, etc as marked by HDR. • Cross sections at 50-foot intervals for estimated length of 400 feet. • Assume sections begin 50 feet upslope of roadway edge to 10 feet south of stream downslope of roadway edge. • Locate borings by x, y, z coordinates where directed by HDR representative. • Tie survey information to State Plane Coordinates NAD83(95) • Conduct survey in accordance with applicable provisions of HDR/DOT general engineering agreement. • Prepare plan and cross section drawings • HDR to coordinate with surveyor 	8/03/05	8/10/05
Item 3	Boring program (Subcontract drilling) <ul style="list-style-type: none"> • Take 6 borings, each a minimum of 10 feet into rock or designated geological unit and install inclinometers in 3 for LT monitoring to establish zone (s) of movement. • Estimate 400 feet of drilling, including soil drilling, rock coring and possible Undisturbed Sample Boring. • Borings will include continuous SPT sampling in soil and NX-size coring in rock. Measure ground water levels and install observation wells. • HDR will set boring locations (with surveyor), provide a geologist or geotechnical engineer for surveillance of activities including field classification and logging of drill samples. <p>HDR will prepare typed boring logs from field logs.</p>	8/17/05	8/26/05

PROPOSED SCOPE OF WORK (Work by HDR unless shown otherwise)		SCHEDULE	
		Begin	Complete
Item 4	Laboratory Testing – Types and (Est No) (Subcontract <ul style="list-style-type: none"> • In-situ moisture contents (40), • Classification tests, Atterberg Limits (20) and Gradations (20) • Unconfined compression strength tests (6) • Triaxial compression strength tests on soil (3) • HDR will provide a list of samples to test, coordinate with testing firm and summarize results. 	8/30/05	9/9/05
Item 5	Evaluation of Alternate Repairs <ul style="list-style-type: none"> • Prepare geotechnical <u>work</u> cross sections (Field sections with TB logs plotted by hand) • Prepare geotechnical plans and cross sections per ODOT requirements (Title sheet and CADD cross sections with schematic boring logs). • Review boring, testing, inclinometer monitoring and other information (e.g. coal information) for potential causes. {Assume up to 6 months for periodic review of monitoring before reaching conclusion. • Develop preliminary design of repairs measures (Assume 3 alternatives) and cost estimates. • Stability analysis for alternates (3) as required • Prepare summary report • Submit to ODOT and review to select final repair method. 	8/30/05	9/23/05
Item 6	Develop Plans for Construction <ul style="list-style-type: none"> • To be determined (TBD) 	TBD	TBD

Project: JEF 152-24.0 (orig Const)	Computed:	Date: 7/8/05
Subject: PID 78724	Checked:	Date:
Task:	Page:	of:
Job #:	No.:	

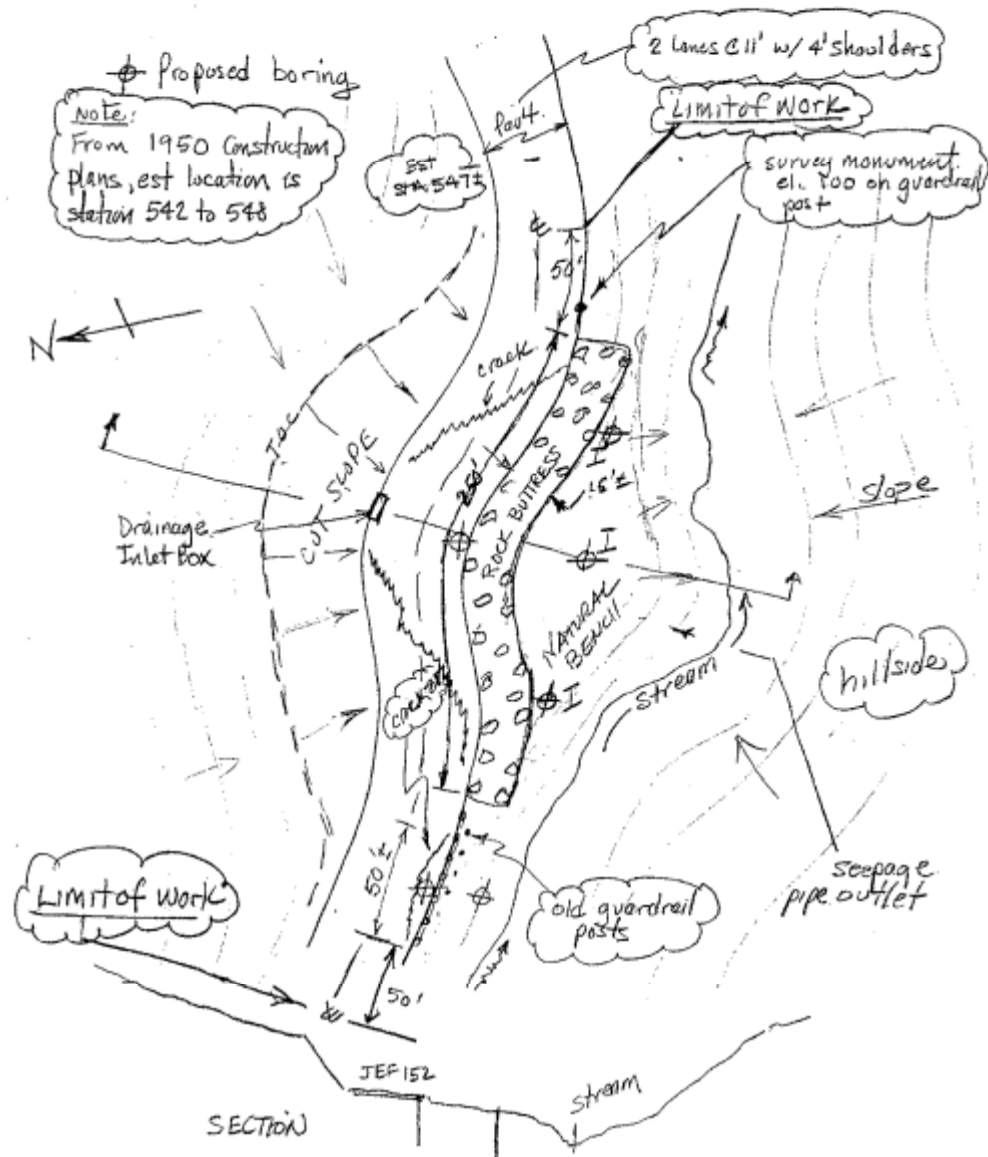

Project: JEF 152 ~24.0	Computed:	Date: 7/8/05
Subject:	Checked:	Date:
Task:	Page:	of:
Job #:	No:	

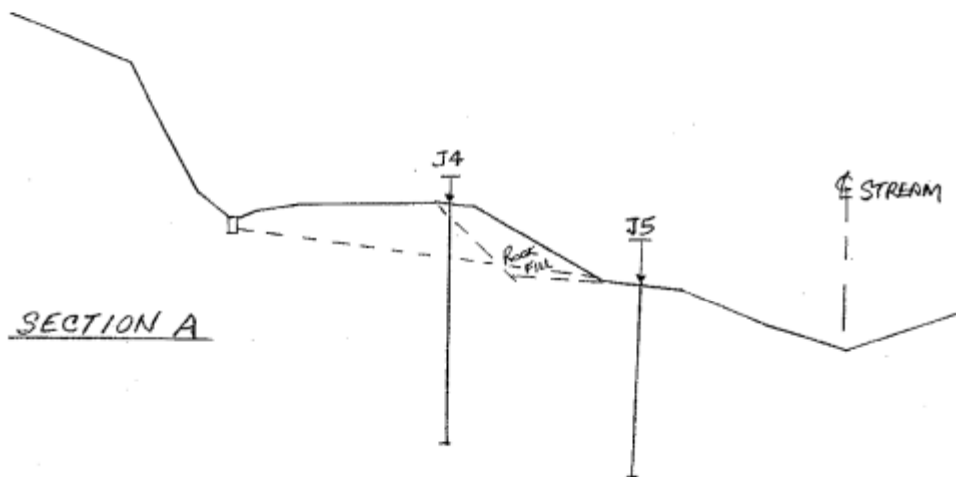
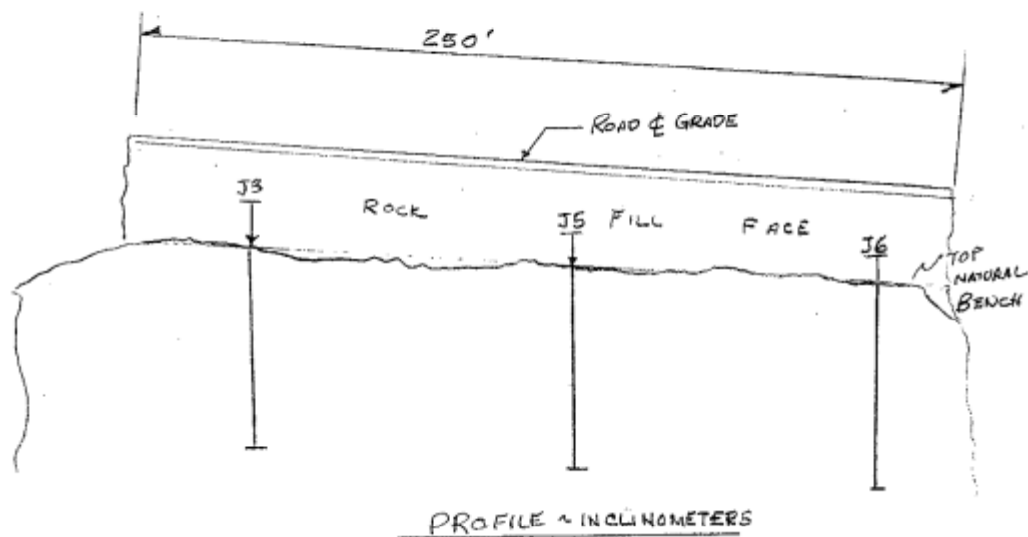



Scoping Memorandum
 JEF 152 SLM 24.0
 PID No. 78724

*TOG-1 & G-2

	classification and logging of drill samples. <ul style="list-style-type: none"> HDR will prepare typed boring logs from field logs. 		
Item 4	Laboratory Testing – Types and (Est No) (Subcontract to) <ul style="list-style-type: none"> In-situ moisture contents (40), Classification tests, Atterberg Limits (20) and Gradations (20) Unconfined compression strength tests (6) Triaxial compression strength tests on soil (3) HDR will provide a list of samples to test, coordinate with testing firm and summarize results. 	8/30/05	Task 11-G
Item 5	Evaluation of Alternate Repairs (Task 11-G-1 work is in italics) <ul style="list-style-type: none"> Prepare geotechnical <u>work</u> cross sections (Field sections with TB logs plotted by hand) Prepare geotechnical plans and cross sections per ODOT requirements (Title sheet and CADD cross sections with schematic boring logs). Review boring, testing, inclinometer monitoring and other information (e.g. coal information) for potential causes. {Assume up to 6 months for periodic review of monitoring before reaching conclusion. Develop preliminary design of repairs measures (Assume 3 alternatives) and cost estimates. Stability analysis for alternates (3) as required Prepare summary report Submit to ODOT and review to select final repair method. <i>Design Anchored Drilled Shaft and Wall along relocated roadway alignment</i> <i>Submit Preliminary Wall Plan, Profile with General Notes and Construction Procedures</i> <i>Submit Drilled Shaft location, estimated top & bottom elevations</i> <i>Review with construction documents with District</i> 	Task 11-G & 11-G-1	12/30/06 *
Item 6	Develop Plans for Construction (Task 11-G-1 work is in Italics) <ul style="list-style-type: none"> <i>Prepare documents for USACOE preconstruction notification</i> <i>Revise Wall Drilled Shaft Cap Beam & Drilled Shaft Location & Els.</i> <i>Furnish Revised Construction Plans, Procedures & General Notes</i> <i>Construction Monitoring</i> 	1/2/07 Task 11-G-1	11/12/07 *
Item 7	Construction Support Services for Anchored Drilled Shaft Supported Wall & S.R. 152 Realignment (Task 11-G-2 Scope of Work) <ul style="list-style-type: none"> Coordinate with department to address construction site stability Support Site PM as needed during drilled shaft installation. Support Site PM as needed during tie-back anchor installation. Review contractors materials, practices and procedures for wall design compliance. Coordinate with District Area Engineer as needed. 	3/1/08 Task 11-G-2	10/30/08 *

The Process (Coordination)

- Monthly Meetings (Minimum)
 - During Design and Construction
 - With DOT and Contractors
 - Review Status of Work and Cost on TOs
- Multiple Subcontracts
 - Survey, Drilling, Laboratory Testing
- Use of Slide Remediation Reports

**Active Task Orders
VAR Driect 11 GES EM 2005-1**

Status as of 2/22/06

Note: Task Orders 11-A, 11-B, 11-B-1, 11-B-2, 11-C and 11-D are completed and closed.

Task Order Work Item (Est % Comp) – Status	Anticipated WI Completion Date
<u>11-A-1 BEL-70-221.2</u> WI 6 Construction Plans for SP Wall (83%) - Calcs completed, completing drawings and QC Review before submission to District	3/7/06
<u>11-D-1 TUS-416-13.0</u> WI 6 Construction Plans for Slope Repair (98%)– Repair plans given to Contractor by District. Remaining HDR work is possible coordination requested by District during construction	TBD
<u>11-E TUS-416-14.3</u> WI 1 Reconnaissance (100% except SOW for WI6) WI 2 Survey (100%) WI 3 Borings (99%) Two add'l inclinometer readings anticipated (March, April) WI 4 Laboratory Testing (100%) WI 5 Evaluate Alt Repairs (33%) Work sections completed. Evaluation, alternate repairs and presentation to District to be completed.	-- -- 4/18/06 -- 4/28/06
<u>11-F BEL-148-12.05</u> WI 1 Reconnaissance (100% except SOW for WI 6) WI 2 Survey (100%) WI 3 Borings (99%) Two add'l inclinometer readings anticipated (March, April) WI 4 Laboratory Testing (100%) WI 5 Evaluate Alt Repairs (26%) Work sections completed. Evaluations, alternate repairs and presentation to District to be completed	-- -- 4/19/06 -- 5/12//06
<u>11-G JEF-152-24.0</u> WI 1 Reconnaissance (100% except SOW for WI 6) WI 2 Survey (100%) WI 3 Borings (99%) Two add'l inclinometer readings anticipated (March, April) WI 4 Laboratory Testing (100%) WI 5 Evaluate Alt Repairs (33%) Work sections completed. Eval`ns, alternate repairs and pres`n to District TBC	-- -- 4/18/06 -- 5/26/06

<p style="text-align: center;">Task Order Work Item (Est % Comp) – Status</p>	<p style="text-align: center;">Anticipated WI Completion Date</p>
<p><u>11-H JEF-150-8.9</u> WI 1 Reconnaissance (100% except SOW for WI 6) WI 2 Survey (100%) WI 3 Borings (99%) Two add'l inclinometer readings anticipated (March, April) WI 4 Laboratory Testing (90%) Testing completed, reviewing and summarizing results WI 5 Evaluate Alt Repairs (15%) Work sections partially completed. Evaluations, alternate repairs and presentation to District to be completed</p>	<p style="text-align: center;">-- -- 4/18/06 3/17/06 6/9/06</p>
<p><u>11-I BEL-CR10-9.93</u> WI 1 Reconnaissance (100% except SOW for WI 6) WI 2 Survey (100%) WI 3 Borings (99%) Two add'l inclinometer readings anticipated (March, April) WI 4 Laboratory Testing (90%) Testing completed, reviewing and summarizing results WI 5 Evaluate Alt Repairs (14%) Work sections partially completed. Evaluations, alternate repairs and presentation to District to be completed.</p>	<p style="text-align: center;">-- -- 4/19/06 3/17/06 6/23/06</p>
<p><u>11-J BEL-CR4-7.72</u> WI 1 Reconnaissance (100% except SOW for WI 6)) WI 2 Survey (75%) Initial work complete. Add'l work underway to locate added TBs and extend topo to pick up add'l movement. Site plan and sections to be completed to include extended survey work. WI 3 Borings (85%) Borings completed, c'king of typed logs TBC, initial and 2 add'l inclinometer readings to be completed WI 4 Laboratory Testing (10%) Samples selected for testing. Testing beginning. WI 5 Evaluate Alt Repairs (0%)</p>	<p style="text-align: center;">-- 3/3/06 4/27/06 3/24/06 7/7/06</p>
<p><u>11-K TUS-212-6.7</u> WI 1 Reconnaissance (50%) Completed site visit, SOW for WI 1-5, review of geologic data & mining records. WI 2 Survey (75%) Survey field work completed. Base plans anticipated 2/27/06. Possible revisions/corrections TBD WI 3 Borings (0%) WI 4 Laboratory Testing (0%) WI 5 Evaluate Alt Repairs (0%)</p>	<p style="text-align: center;">7/21/06 3/31/06 5/26/06 6/16/06 7/21/06</p>
<p><u>11-L TUS-212-7.6</u> WI 1 Reconnaissance (50%) Completed site visit, SOW for WI 1-5, review of geologic data & mining records. WI 2 Survey (75%) Survey field work completed. Base plans anticipated 2/27/06. Possible revisions/corrections TBD WI 3 Borings (0%) WI 4 Laboratory Testing (0%) WI 5 Evaluate Alt Repairs (0%)</p>	<p style="text-align: center;">7/21/06 3/31/06 5/26/06 6/16/06 7/21/06</p>

The Process - Construction

- Type A Contract-T & M –Force Account
- Selected from District List of Contractors
 - Good Performance Record with District
 - Match Strength with Work (e.g. Walls, Earthmoving)
 - Workload & Resources
 - Record keeping abilities

CONSTRUCTION PROCEDURES BEL COUNTY ROUTE 4

Construction of the Grading and Sub-Drainage Repair of the slide onto C.R. 4 will require the following procedures for construction:

1. Install a new pipe for a new catch basin starting from the tributary to McMahon Creek near approximate baseline station 9+60 where the tributary crosses under County Route 4.
 4. Complete the pipe installation and backfill to the catch basin location at station 11+75.
 - a. At stations 10+00 to 11+50, look for an old mine entry that may produce acid-mine drainage (AMD). Treat AMD and back-pack the entry opening.
 - b. If required the existing steep slope at the edge of the road can be laid back, but it must not disturb the power line pole that is set back from the top of the slope at station 10+50 offset 71 feet right of the baseline.
 2. Place a temporary standpipe with a geotechnical fabric sock at the catch basin location for collecting seepage and silt during construction of the sub-drainage system. Secure the connection from the temporary standpipe with the permanent outlet pipe to keep silt out of the permanent drainage pipe.
 3. Remove and stockpile the saturated soil on the slope 75 feet on either side of the planned slope trench centerline. The underlying soil that remains on the slope will be very stiff to hard clayey silt that overlies weathered rock and bedrock. Maintain drainage for seepage and storm water to the standpipe at the end of each day's work.
 - a. Note a separate topsoil stockpile should be established at the site.
 4. Excavate the sub-drainage trench at station 12+50 from the bottom of the slope to the top. Bottom of the trench must expose the bedrock surface. Place excavated clayey silt and weathered rock along side of the trench at station 12+00. Allow all seepage from the bedrock to drain to the standpipe.
 - a. Beside the main trench, a two foot wide side trench may be required to drain wet spots that may be found between here and the temporary limit of excavation ahead of station as shown on the plan.
 - b. Backfill the side trench in the same manner as the main trench requires.
 5. After seepage flow runs clear on the bedrock surface, place durable rock cobbles into the trench from the bottom to the top, tamping the surface with the backhoe bucket for a tight fill. Allow water to flow to the standpipe at all times.
 6. After choking the rock surface with AASHTO No. 3 aggregate, install the geotextile fabric full width with a minimum side lap of two feet beyond the edge of the rock backfill and begin soil backfill over the geotextile. Using the trench excavated material mixed with the saturated soil (to temper the moisture content) from the stockpile, compact backfill as required to the top of the trench excavation from the lowest trench excavation elevation to the highest.
-

7. Allow enough of the bottom end of the sub-drainage trench rock exposed near the roadway ditch line for seepage to drain to the standpipe. Then repeat steps 3 through 6 at station 13+90 and then 15+40 always allowing seepage flow to exit the bottom of each slope sub-drain.
 - a. Prior to step 3 at station 13+90, the power line pole must be relocated by the utility owner to a place that allows safe completion of the grading and drainage work.
 8. Once all slope sub-drains are installed, repeat step 4 for the connecting sub-drain that runs parallel to the roadway. After the seepage from the 3 slope sub-drains runs clear, remove silt and then the connection piece from the outlet pipe to the standpipe.
 9. Install a geotextile sock over the inlet end to the permanent pipe and securely clamp around the pipe circumference. Clean out all remaining silt and remove the standpipe.
 10. Install the catch basin base (ODOT Type 5) over the inlet of the permanent pipe after cleaning out any debris and placing a granular base material. Complete the catch basin installation along with backfill steps 5 and 6 including a perforated plastic pipe from the catch basin to station 15+40 along the roadway sub-drain trench. Cut off the outlet pipe flush with the interior of the catch basin and seal around the pipe.
 - a. Make sure the perforated plastic pipe is well below frost penetration depth at all locations. The exit end of the perforated pipe should be at least one foot above the invert of the permanent outlet pipe drain. Do not seal around the perforated pipe inside the catch basin.
 11. Form the roadway ditch to the new catch basin. Protect the catch basin from silt at all times using an accepted silt barrier fence.
 12. Using the trench excavated material mixed with the saturated soil, construct the embankment as shown on cross sections. Follow good construction practice by cutting into the sloping compacted soil backfill when constructing embankment in near level lifts. Over-fill the slope line and cut back to form a solid slope conforming to the intent of the cross section.
 13. If excess material is available after the first (bottom slope bench above the roadway) bench is completed, slope steepness above the first bench may be increased if desired. Compacted fill slope must not be steeper than 2H:1V for permanent new vegetation.
 14. After reclaiming and spreading the topsoil, seed and mulch all disturbed surfaces within the project limits.
-

A Closer Look

- BEL-149-0.8
- JEF-152-24.0
- JEF-150-8.9
- BEL-CR-4-7.72
- BEL-70-22.58 (I-70)

BEL-149-0.8



4.5.05



4.5.05

4.13.05



4.13.05







4.5.05

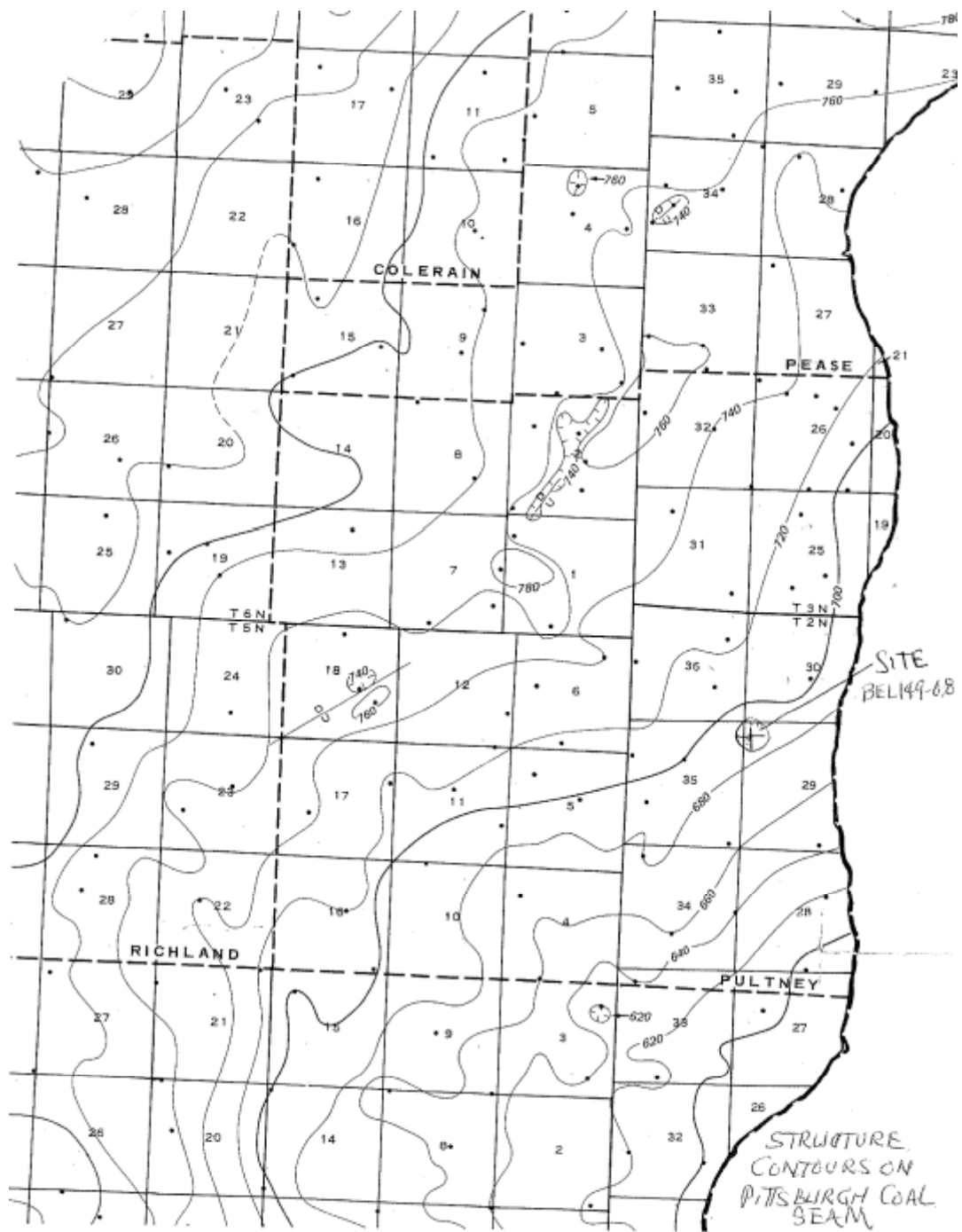

Page	Owner
251	The Boudage Streets and Lane Company
252	City of Baltimore
253	Martin Anderson
254	City of Baltimore
255	City of Baltimore
256	The Boudage Streets and Lane Company
257	City of Baltimore
258	City of Baltimore
259	City of Baltimore
260	City of Baltimore
261	City of Baltimore
262	City of Baltimore
263	City of Baltimore
264	City of Baltimore
265	City of Baltimore
266	City of Baltimore
267	City of Baltimore

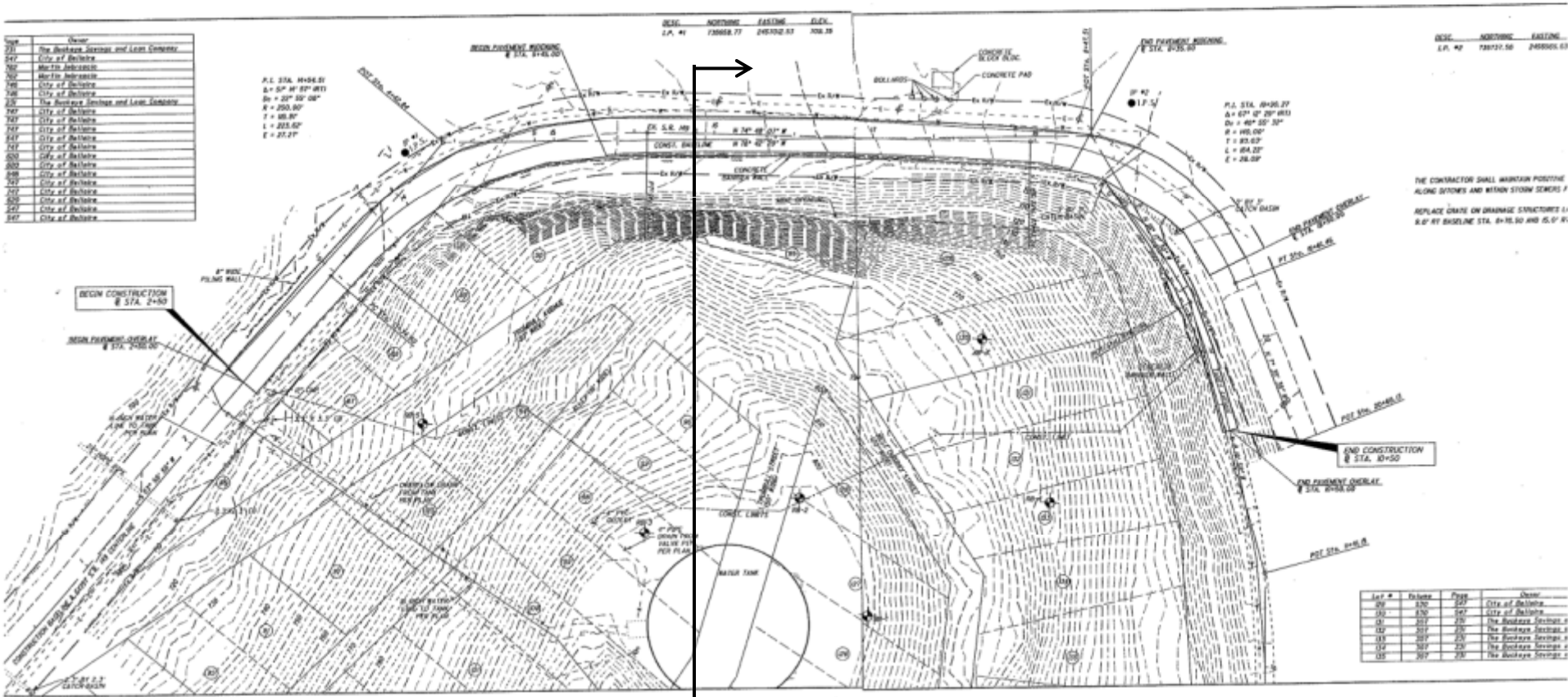

6+00

Page #	Station	Page	Owner
251	1+00	251	City of Baltimore
252	2+00	252	City of Baltimore
253	3+00	253	The Boudage Streets & Lane Co.
254	4+00	254	The Boudage Streets & Lane Co.
255	5+00	255	The Boudage Streets & Lane Co.
256	6+00	256	The Boudage Streets & Lane Co.
257	7+00	257	The Boudage Streets & Lane Co.

THE CONTRACTOR SHALL MAINTAIN POSITIVE
ALONG STONES AND BRICK STONE SEWERS &
REPLACE GRADE ON DRAINAGE STRUCTURES 1'
8.0' BY BENCHMARK STA. 8+15.00 AND 15.0' BY

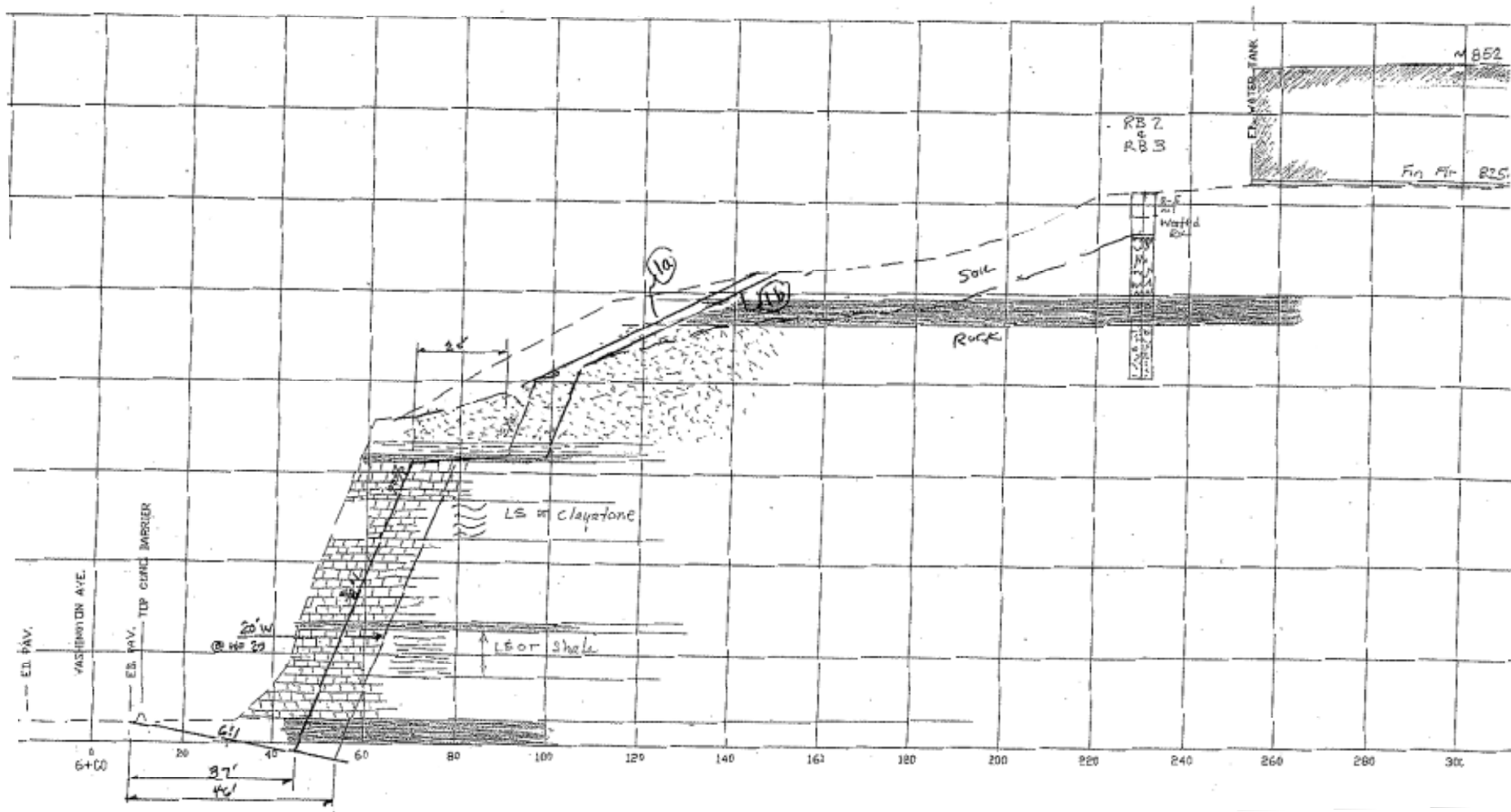

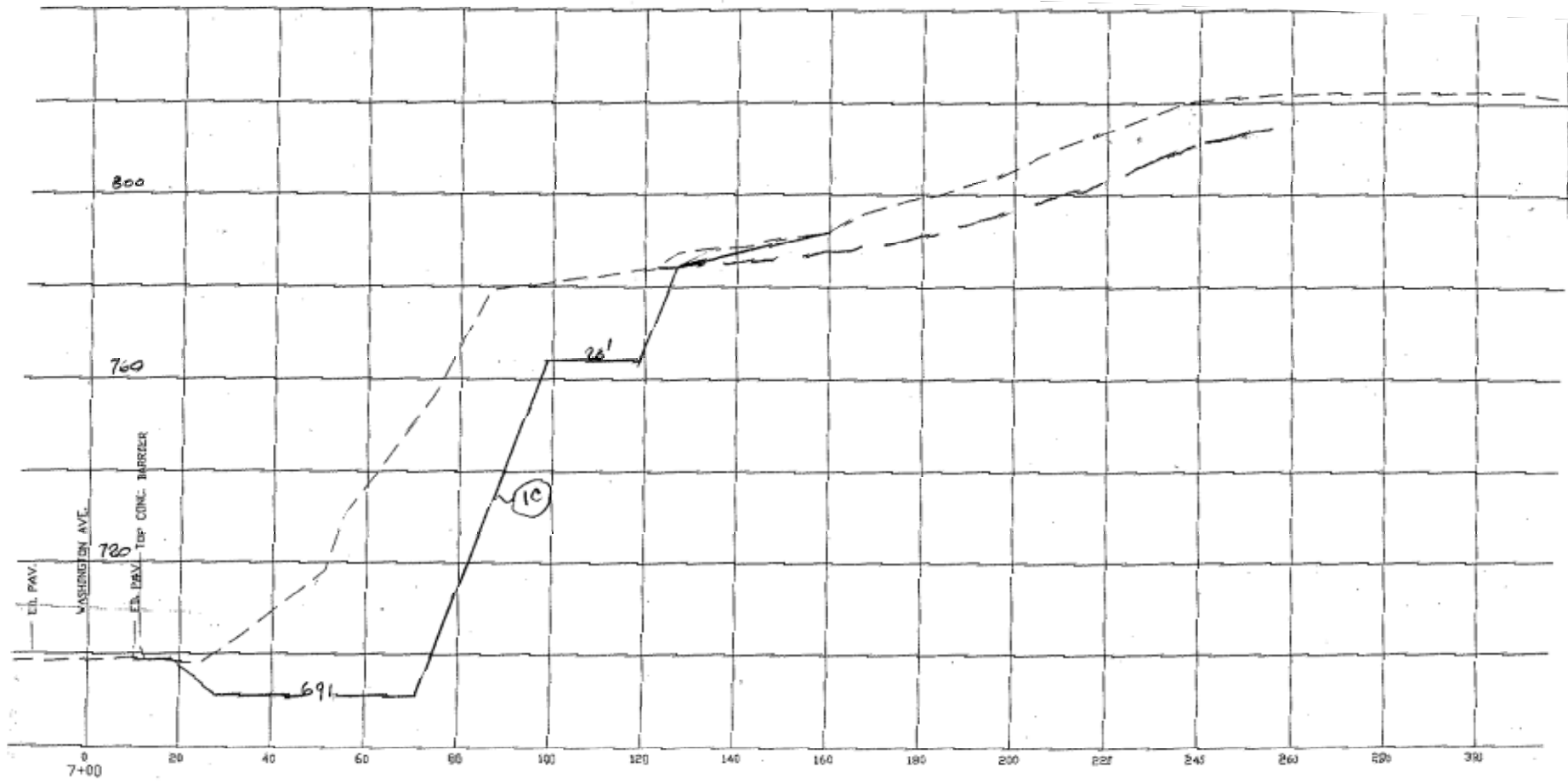

OPTION 1C RITCHIE DITCH

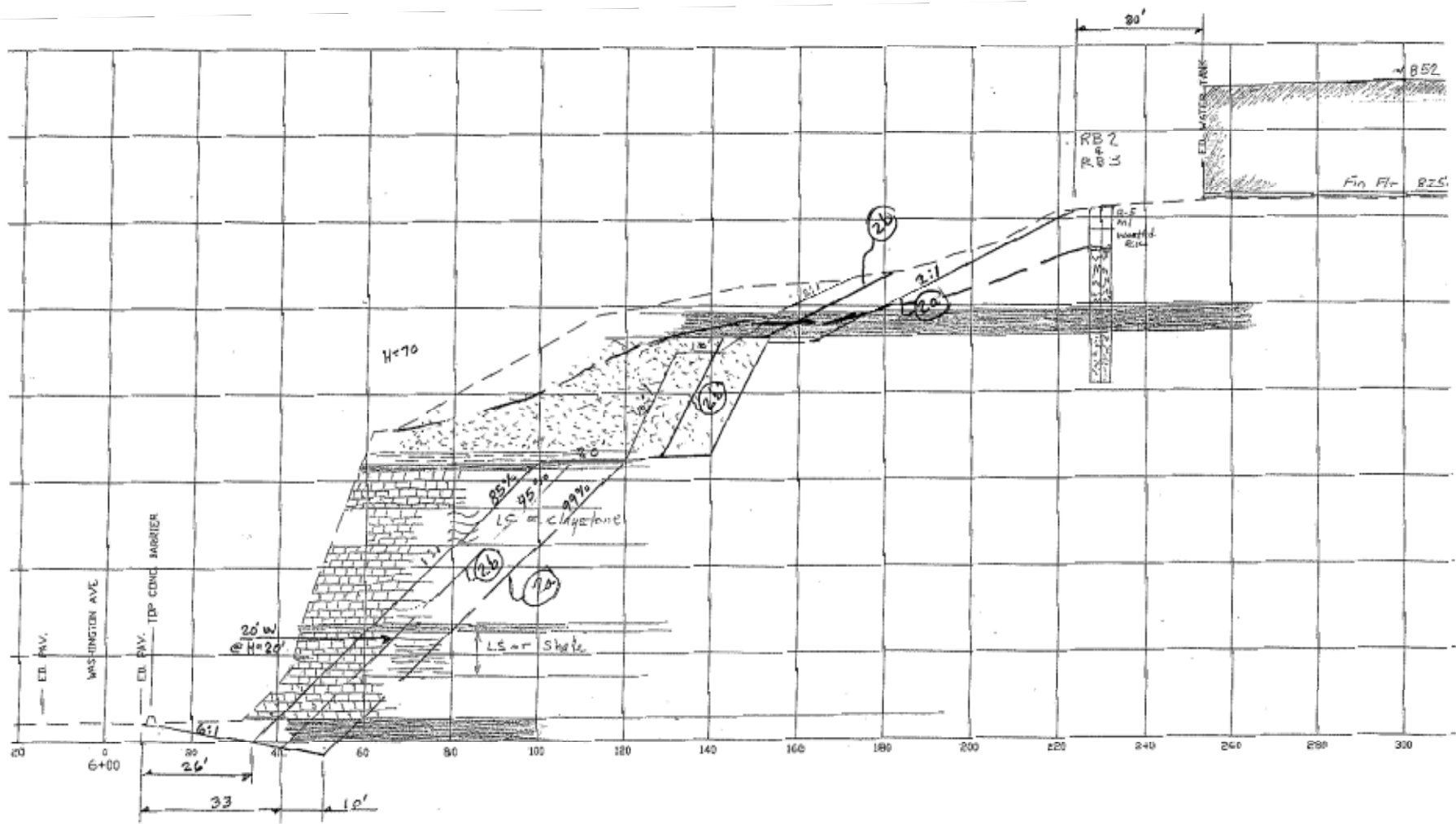

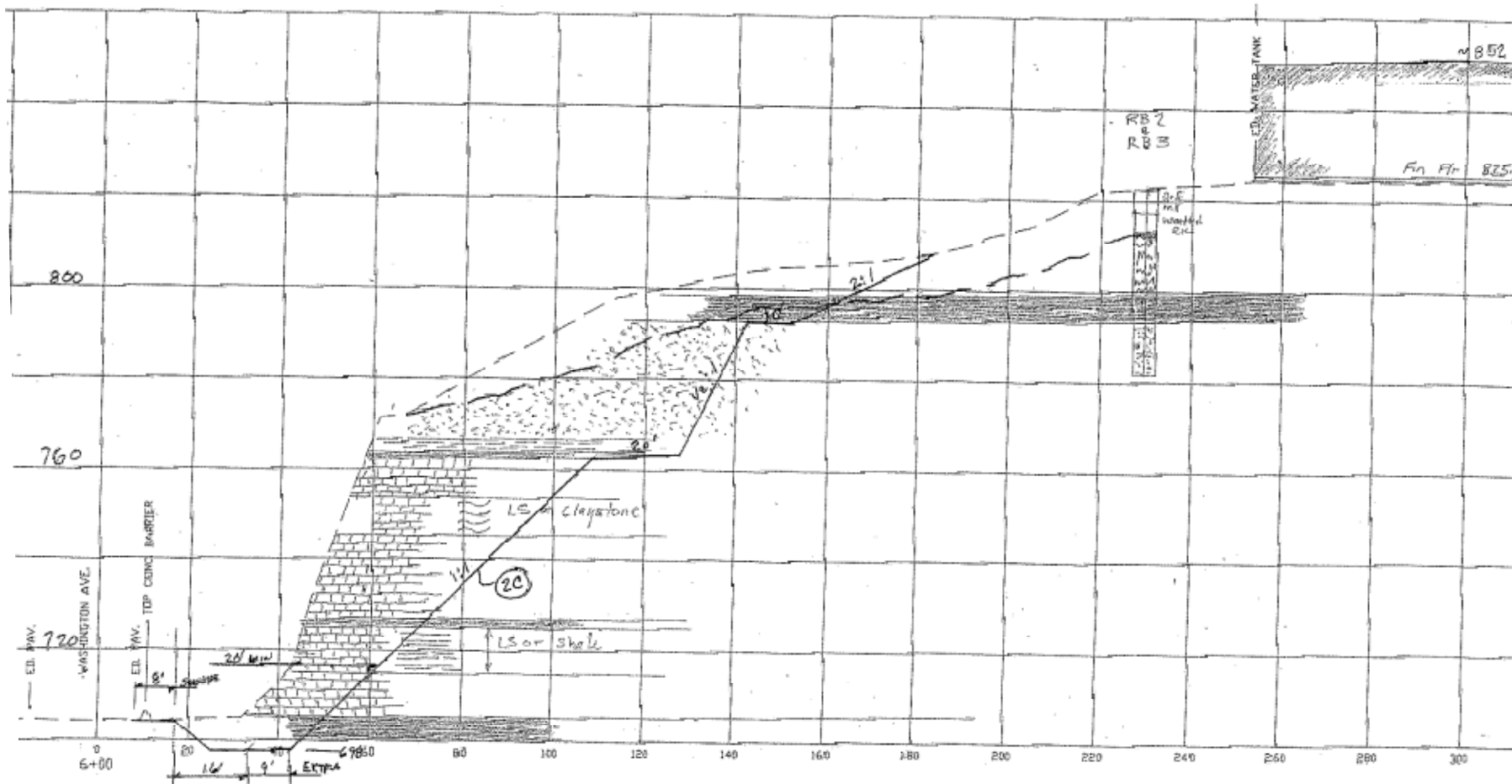

OPT (2C)

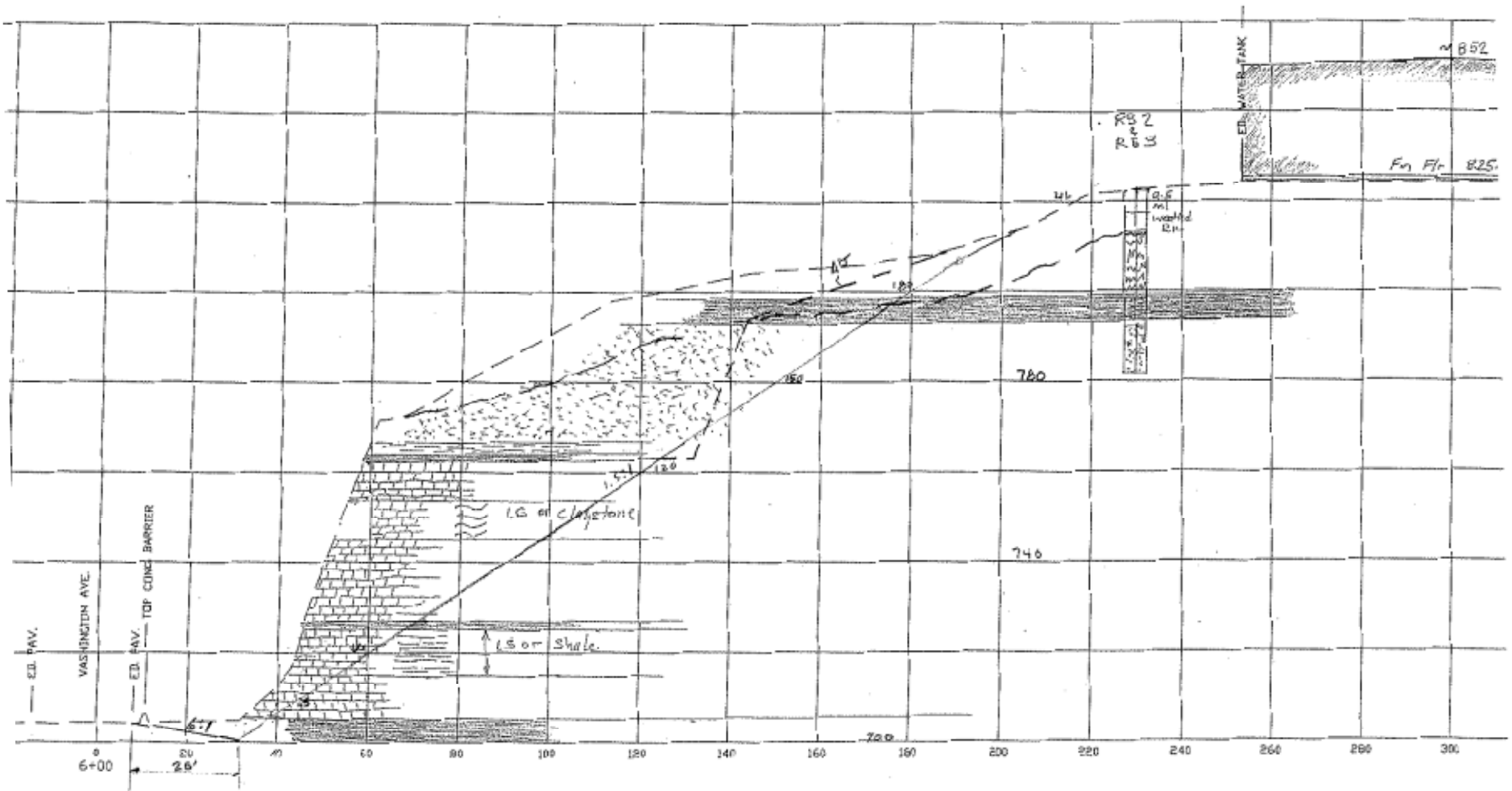

OPT (3a)

BEL 149-0.8 Remediation Options Evaluated

Preliminary Estimate of Cost

(w 15% Contingency)

Option	Description	PEoC
1A	70-degree (0.375H:1V) slope w 99% Protection	\$898,700
1B	70-degree (0.375H:1V) slope w 20' min cut width	\$1,082,600
1C	70-degree (0.375H:1V) slope w Ritchie Ditch	\$1,404,900
2A	45-degree (1H:1V) slope w 99% Protection	\$2,075,000
2B	45-degree (1H:1V) slope w 20' min cut width	\$1,580,300
2C	45-degree (1H:1V) slope w Ritchie Ditch	\$1,550,300
3A	34-degree (1.5H:1V) slope w 99% protection	\$1,420,600

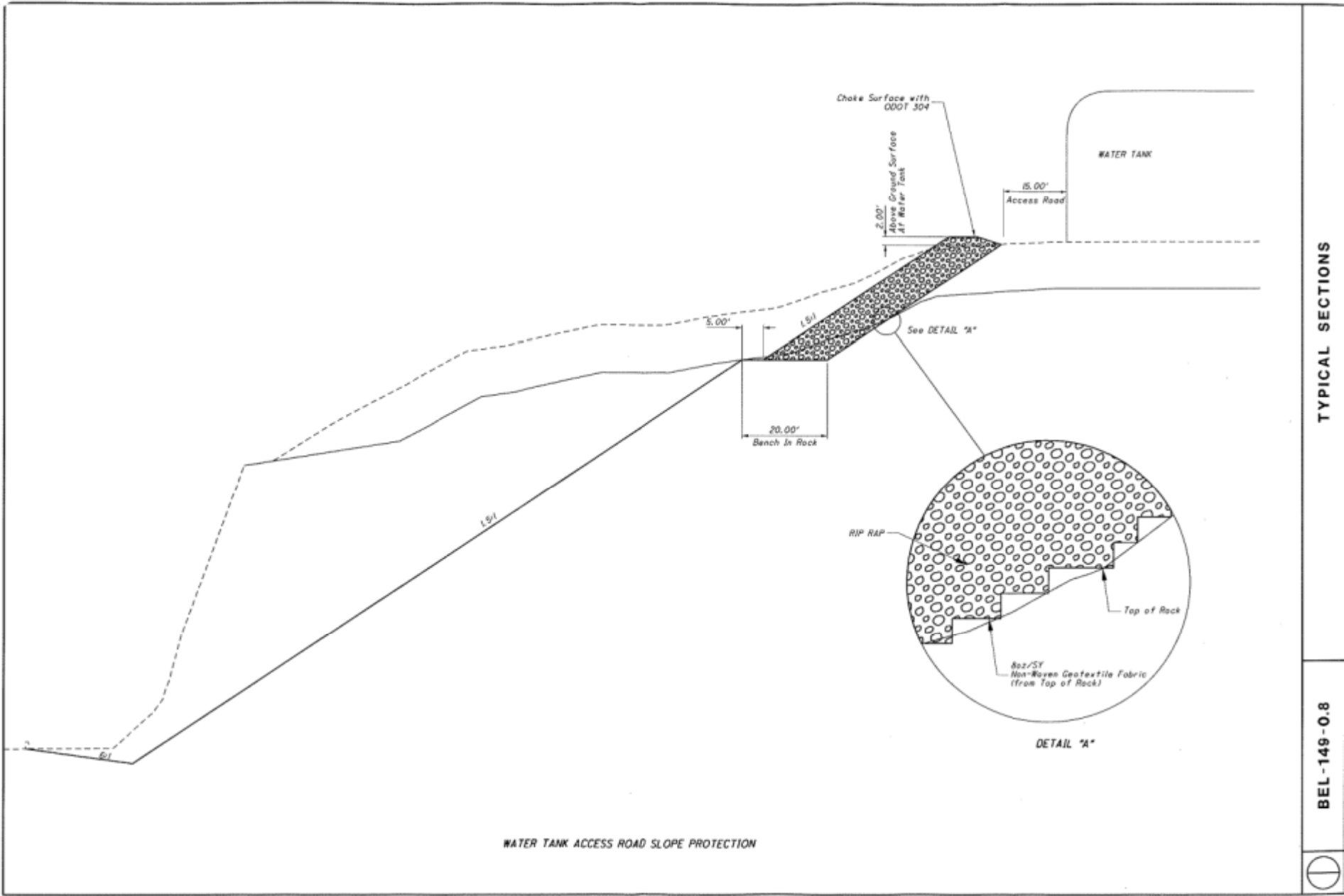

TYPICAL SECTIONS

BEL-149-0.8





Repairs Completed



8.5.05



11.17.05



11.17.05



11.17.05



11.17.05

11.17.05





11.17.05



JEF 150-8.9

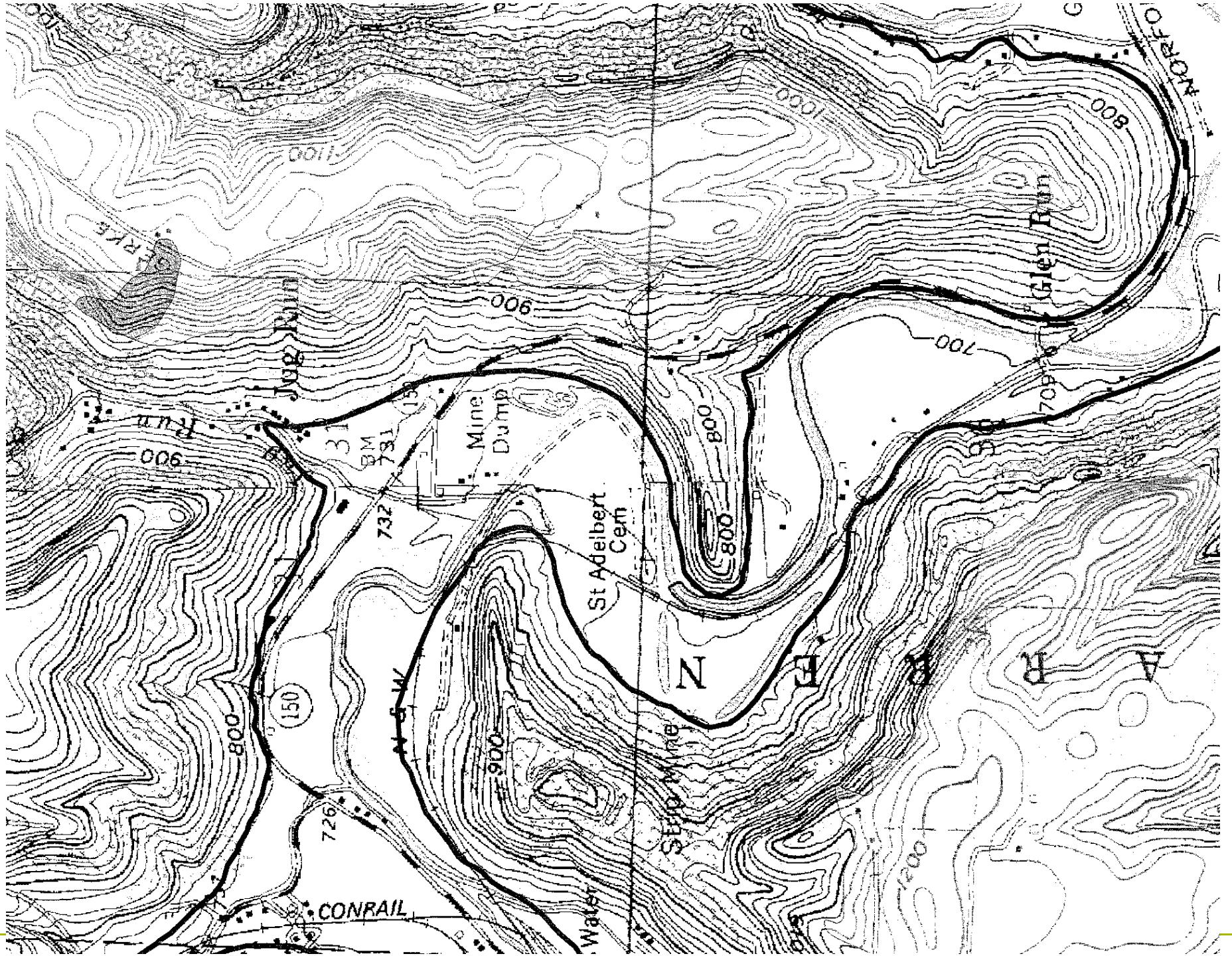





2.9.05







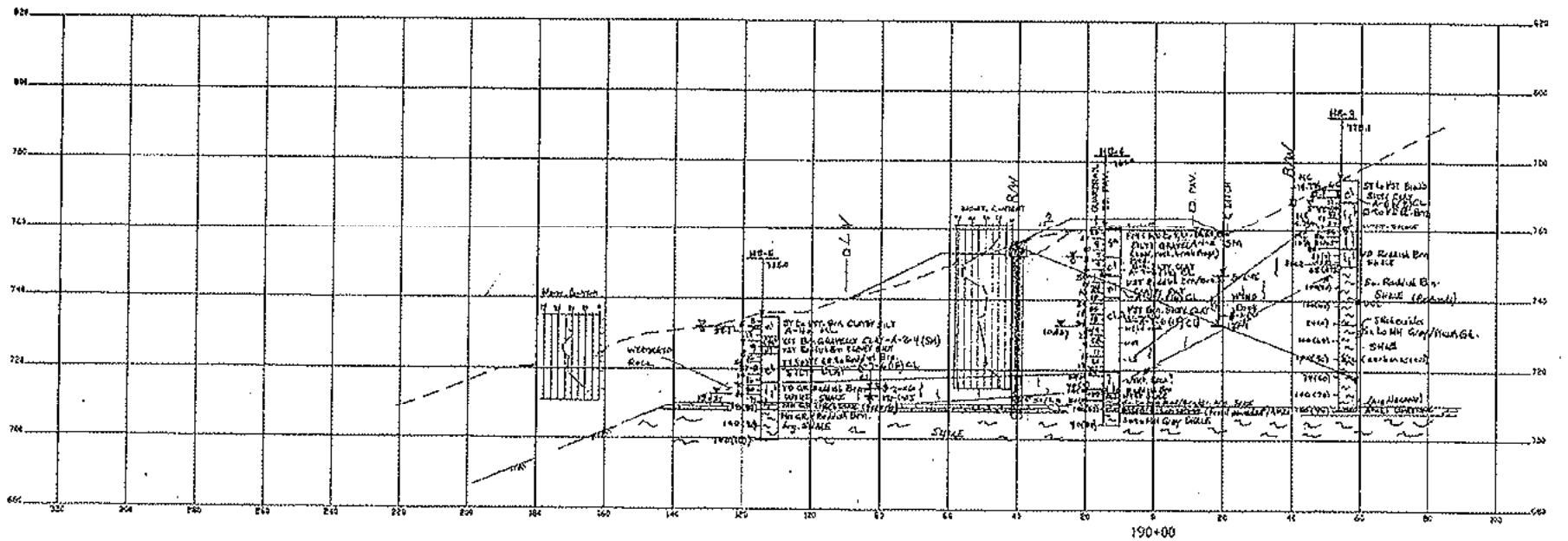
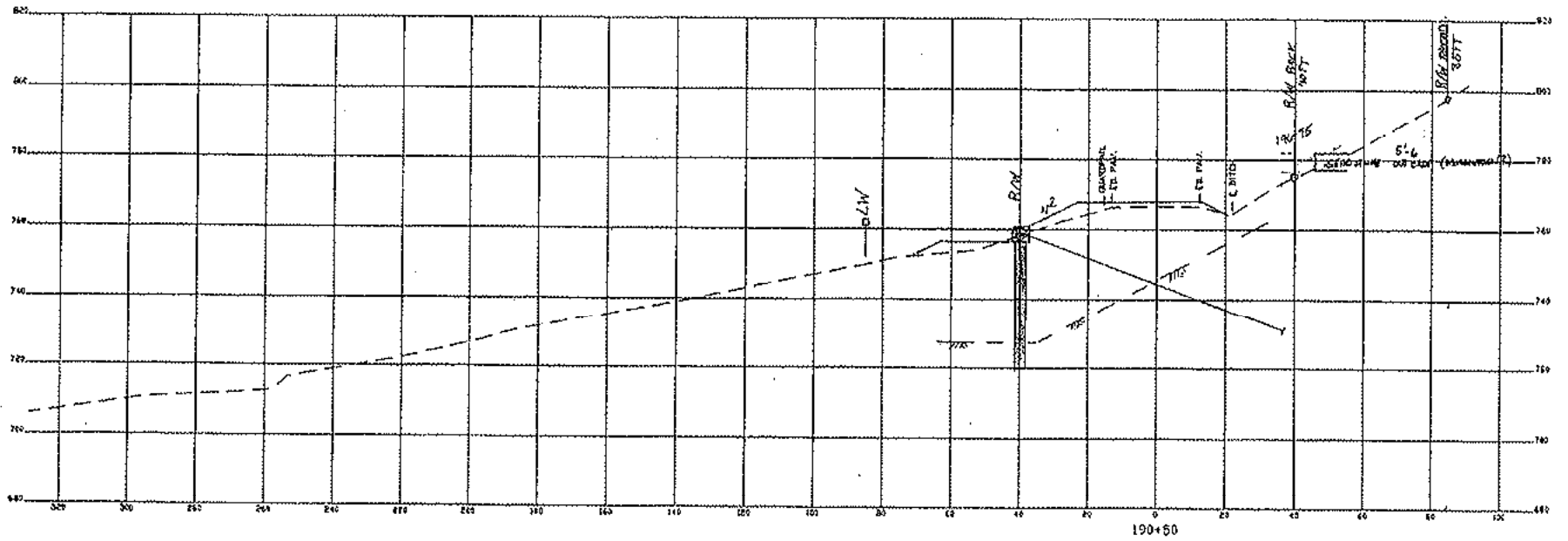

JEF-150-8.9 Remediation Options Evaluated

Preliminary Estimate of Costs

(w 15% Contingency)

Option	Description	PEoC
1	Two-tiered, Anchored Drilled Shaft Wall	\$2,050,000
2	Remove and Reconstruct Embankment with Geofoam & Pile Shear Key at Short Creek	\$2,520,000
3	Anchored Drilled Shaft Wall with Rock Buttress at Short Creek	\$2,080,000



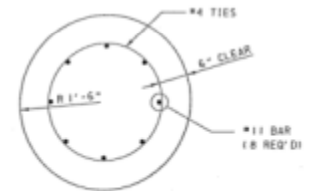
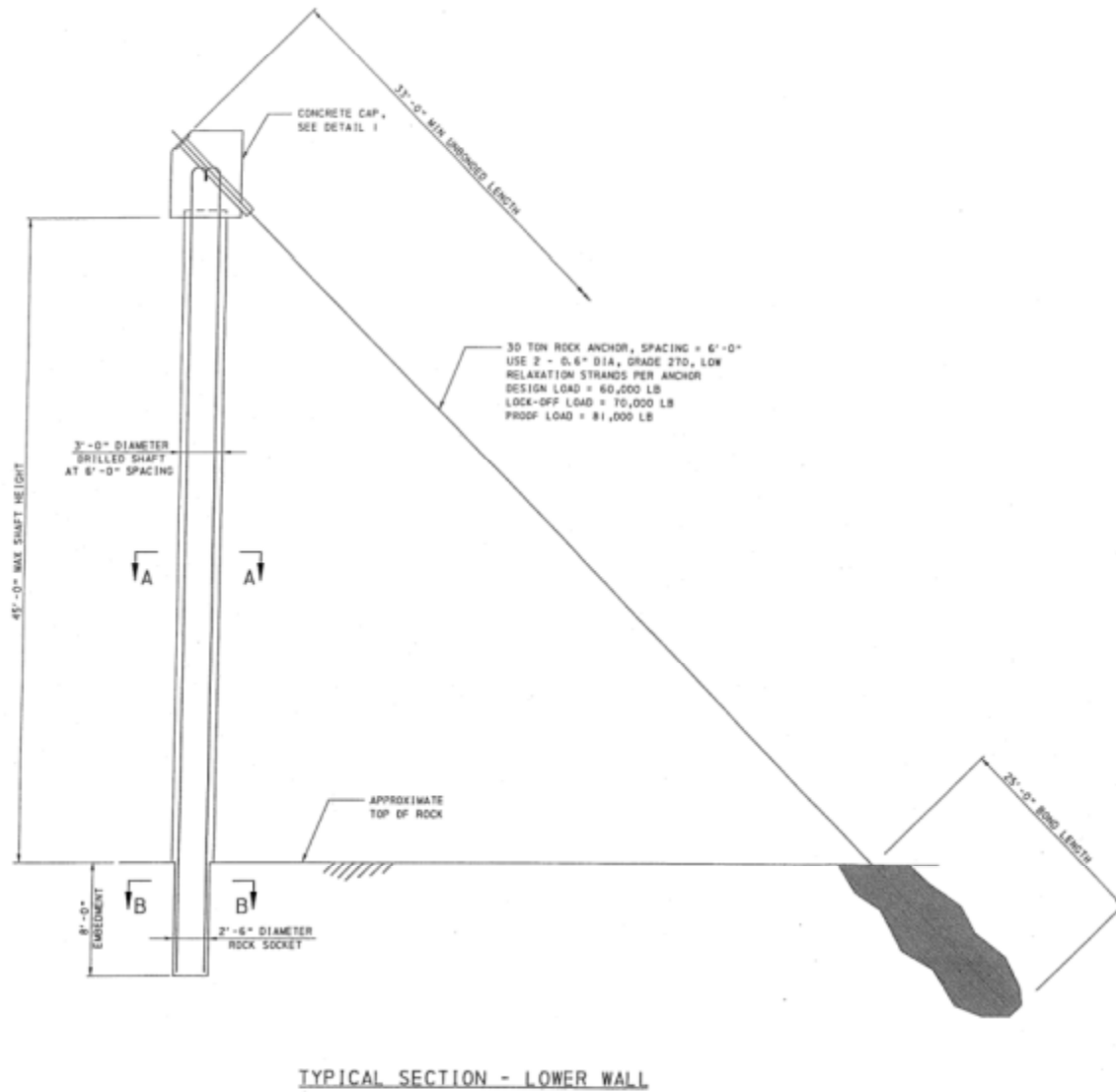

SECTION A-A

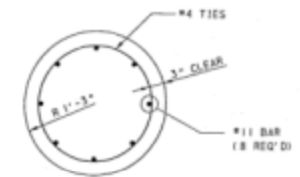

SECTION B-B

NOTES

1. ALL CONCRETE TO HAVE $f'c = 3,000$ PSI MINIMUM.
2. ALL REINFORCING TO BE GRADE 60 MINIMUM.

Work	Description	By	Chk'd	Rec'd	Date
REVISIONS					

OHIO DEPARTMENT OF TRANSPORTATION	
JEF 150 (8.9)	
LOWER ANCHOR WALL TYPICAL SECTION	
RECOMMENDED _____	SHEET 1 OF 4

GENERAL NOTES: SEE SHEET JEF 150 (8.9) FOR ANCHOR WALL TYPICAL SECTION. SEE SHEET JEF 150 (8.9) FOR ANCHOR WALL TYPICAL SECTION. SEE SHEET JEF 150 (8.9) FOR ANCHOR WALL TYPICAL SECTION.

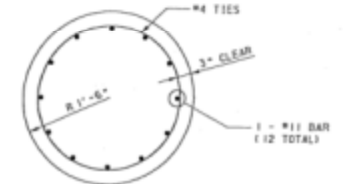
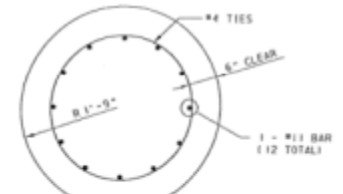
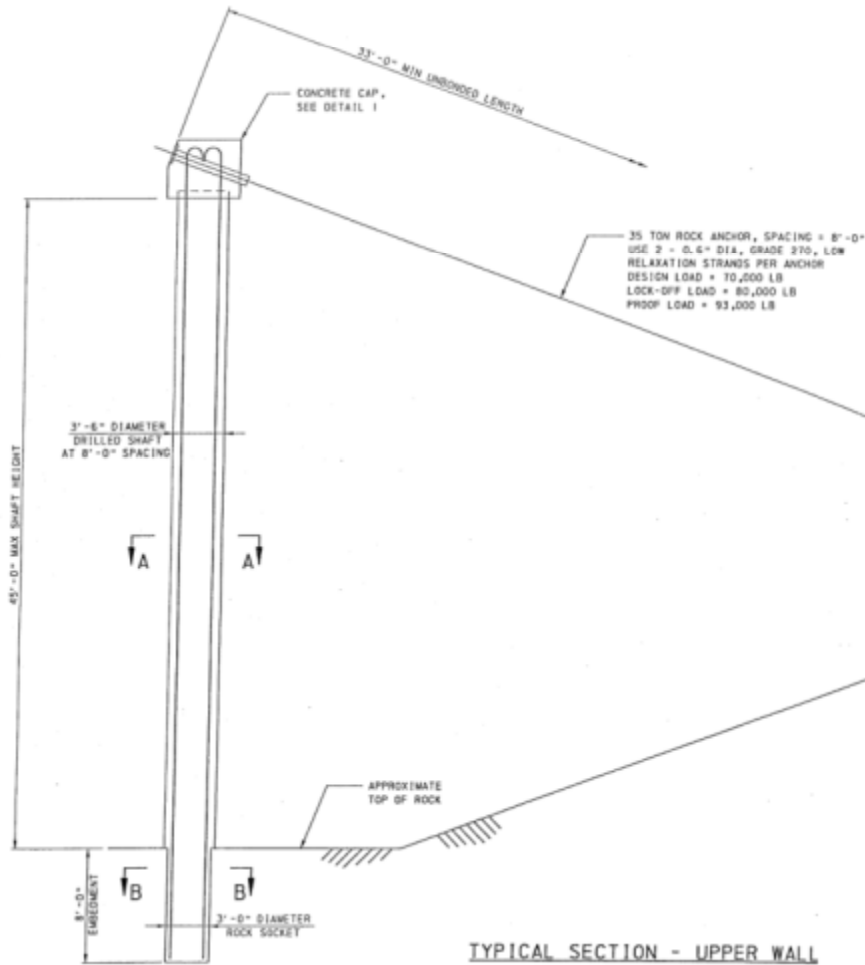

NOTES:

1. ALL CONCRETE TO HAVE $f'c = 3,000$ PSI MINIMUM.
2. ALL REINFORCING TO BE GRADE 60 MINIMUM.

Work	Description	By	Chk'd	Rec'd	Date
REVISIONS					

OHIO
 DEPARTMENT OF TRANSPORTATION

JEF 150 (8.9)

UPPER ANCHOR WALL
 TYPICAL SECTION

RECOMMENDED _____ SHEET 3 OF 4

DESIGNED BY: _____
 CHECKED BY: _____
 DATE: _____
 DRAWN BY: _____
 DATE: _____
 SCALE: _____
 SHEET NO.: _____

DESIGN SET | ENGINE SET | CHECKED BY





















JEF-152-24.0

















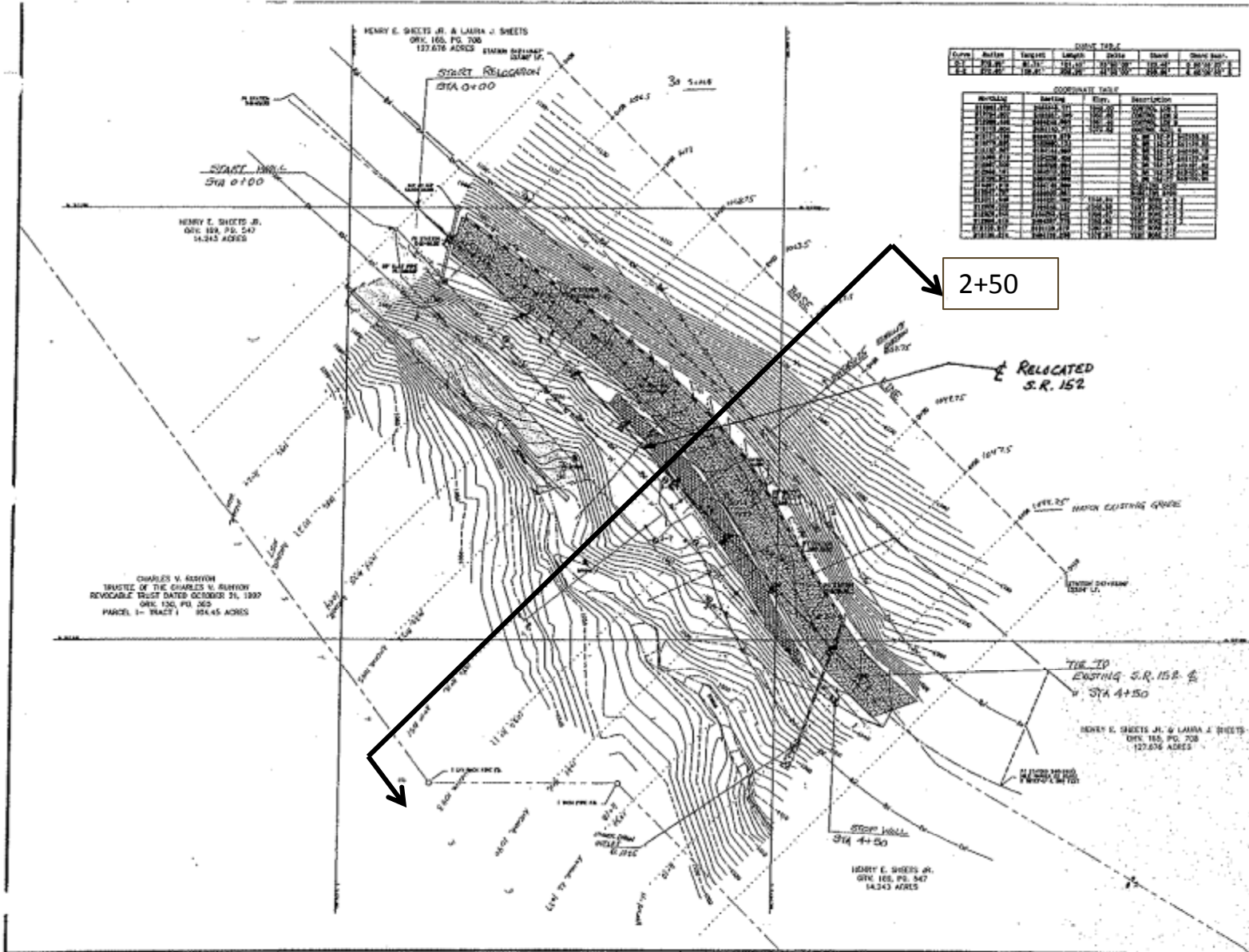

Curve	Station	Length	Radius	Grade	Grade
1	2+00	100.00	1000.00	2.00%	2.00%
2	3+00	100.00	1000.00	2.00%	2.00%

NO.	STATION	ELEV.	DESCRIPTION
1	2+00	100.00	START OF CURVE
2	2+50	100.00	POINT OF TANGENCY
3	3+00	100.00	END OF CURVE
4	3+50	100.00	START OF CURVE
5	4+00	100.00	POINT OF TANGENCY
6	4+50	100.00	END OF CURVE



- NOTES:
1. HORIZONTAL / VERTICAL DATUM REFERS TO NAD83 (97) GRS (NORTH ZONE), NAVD 83 (EGM96 GRS) BASED ON JEFFERSON COUNTY MOVEMENT 22/43.
 2. THE RE-ESTABLISHMENT OF S.R. 152 RIGHT OF WAY AND CENTERLINE STATIONING SHOWN HEREON IS BASED ON CONSTRUCTION PLAN JEF-152-(35.70-34.28) SHEET 12/42, INCLUDING EXISTING CURBSETS AND PAVEMENT LOCATIONS THROUGHOUT AND ADJACENT TO THE LIMITS OF THE DRIVEY AREA.

TONY L. GOSIL, PLS, PLS
 INFORMATION SHOWN HEREON IS BASED ON A FIELD SURVEY PERFORMED BY OR UNDER MY DIRECT SUPERVISION AND IS CORRECT TO THE BEST OF MY KNOWLEDGE AND BELIEF.

LEGEND

- CONSTRUCTION CORNER/POINT
- BENCHMARK/LOCATION MARK-STAKED
- TELEPHONE POLE
- TELEPHONE LINE/ADJACENT
- GRAVEL ASPHALT
- GENERAL
- PROPERTY LINE
- ON OR NEAR RIGHT OF WAY
- POCKETS/STAKES
- SHEDS/CONCRETE
- CONCRETE ASPHALT

OPTION B ANCHOR THE BACK RAIL ON STRAIGHT ALIGNMENT S.R. 152 - SLM 24.0
 CDDT PID # 78724 - TASK ORDER 1E-G
 SECTION 4, TWP. R. 2, KNOX TWP.
 JEFFERSON COUNTY, OHIO
 PLANVIEW
 -8.0% GRADE

HAMILTON
 341 High St., Box 471
 Bowling Ohio 43007
 Ph: (614) 890-0247
 Fax: (614) 898-4325
 e-mail: hamlton@hamp.com
 www.hamp.com

NO.	REVISION	DATE	BY

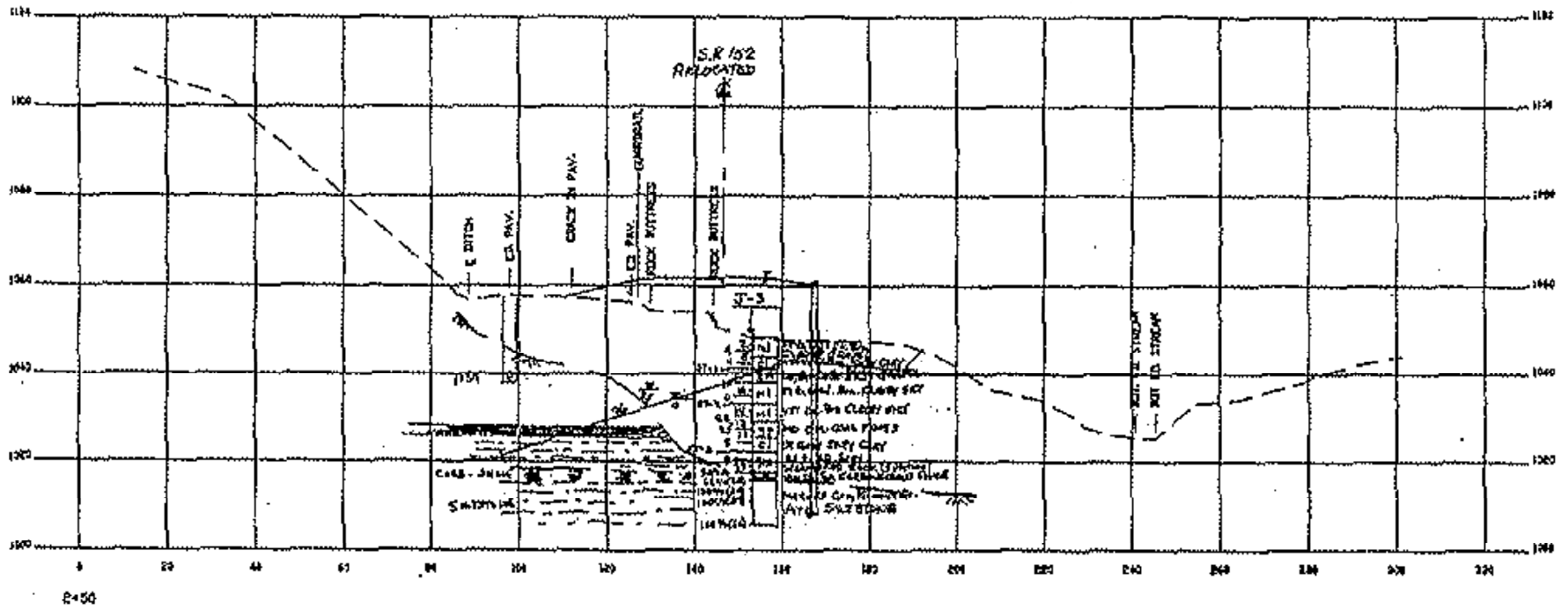

Station 2+50

JEF-152-24.0 Remediation Options Evaluated Preliminary Estimate of Costs (w 15% Contingency)

Option	Description	PEoC
1	Straighten Alignment Remove Slide & Replace	\$2,200,000
2	Straighten Alignment w/Gravity Wall over Anchored DS Wall	\$1,400,000
3	Straighten Alignment w/2 Tiered SP and Gravity Wall	\$1,600,000

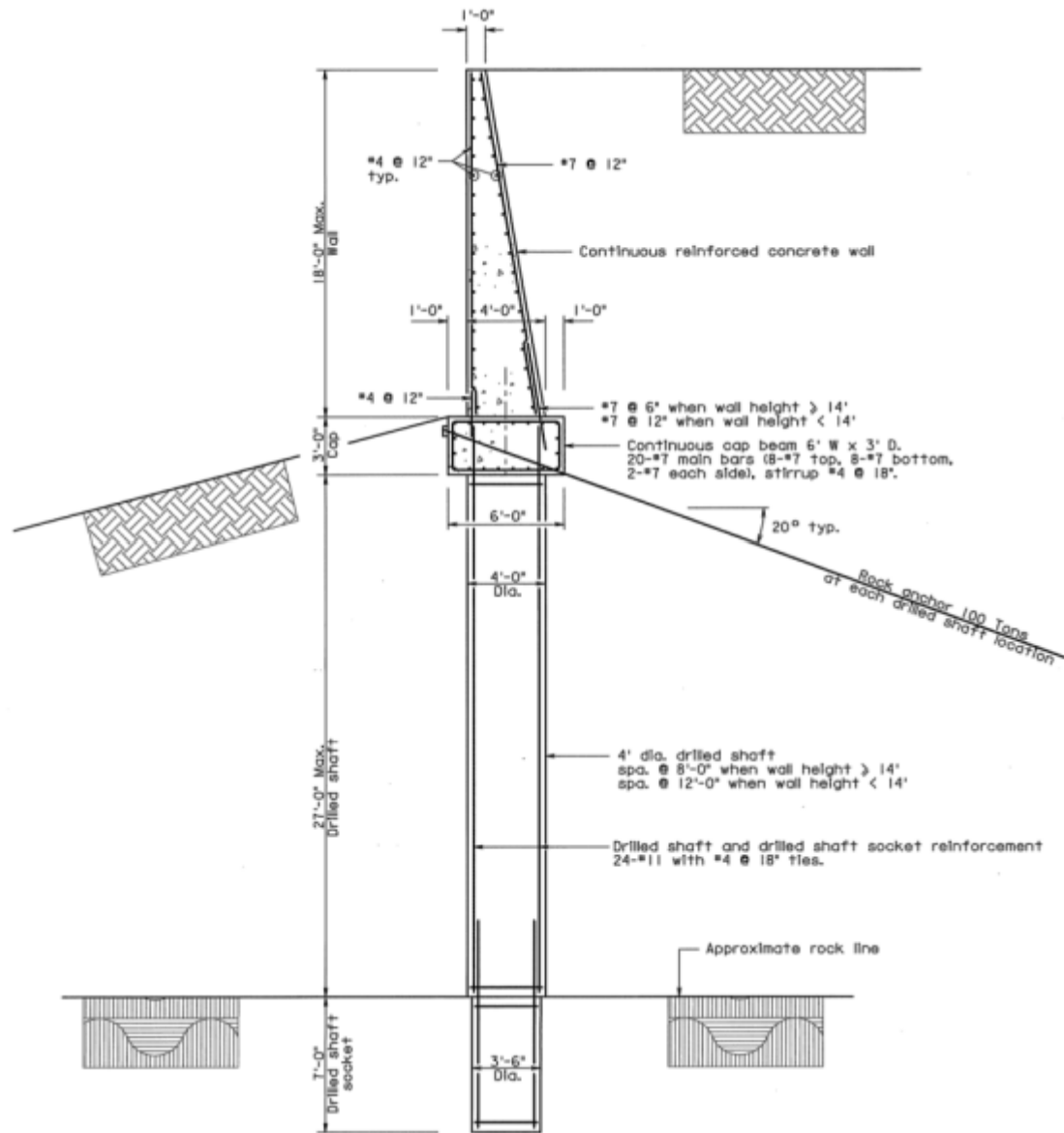

WALL SECTION

Not to scale





30 inches of pavement exposed

















BEL-CR-4-7.72











HORIZONTAL / VERTICAL DATUM REFERS TO NAD83 (FEET) / NAVD83 (FEET) ZONE 16, PLATON AS CALSRD PG. 84511 ON BELMONT COUNTY GPS PROJECT MOVEMENT FILE.

Locals BRAGS 8, 9, 10, 11

FIRM ROAD

NEW 5 P. HALL LADDER SUBS. LUMP

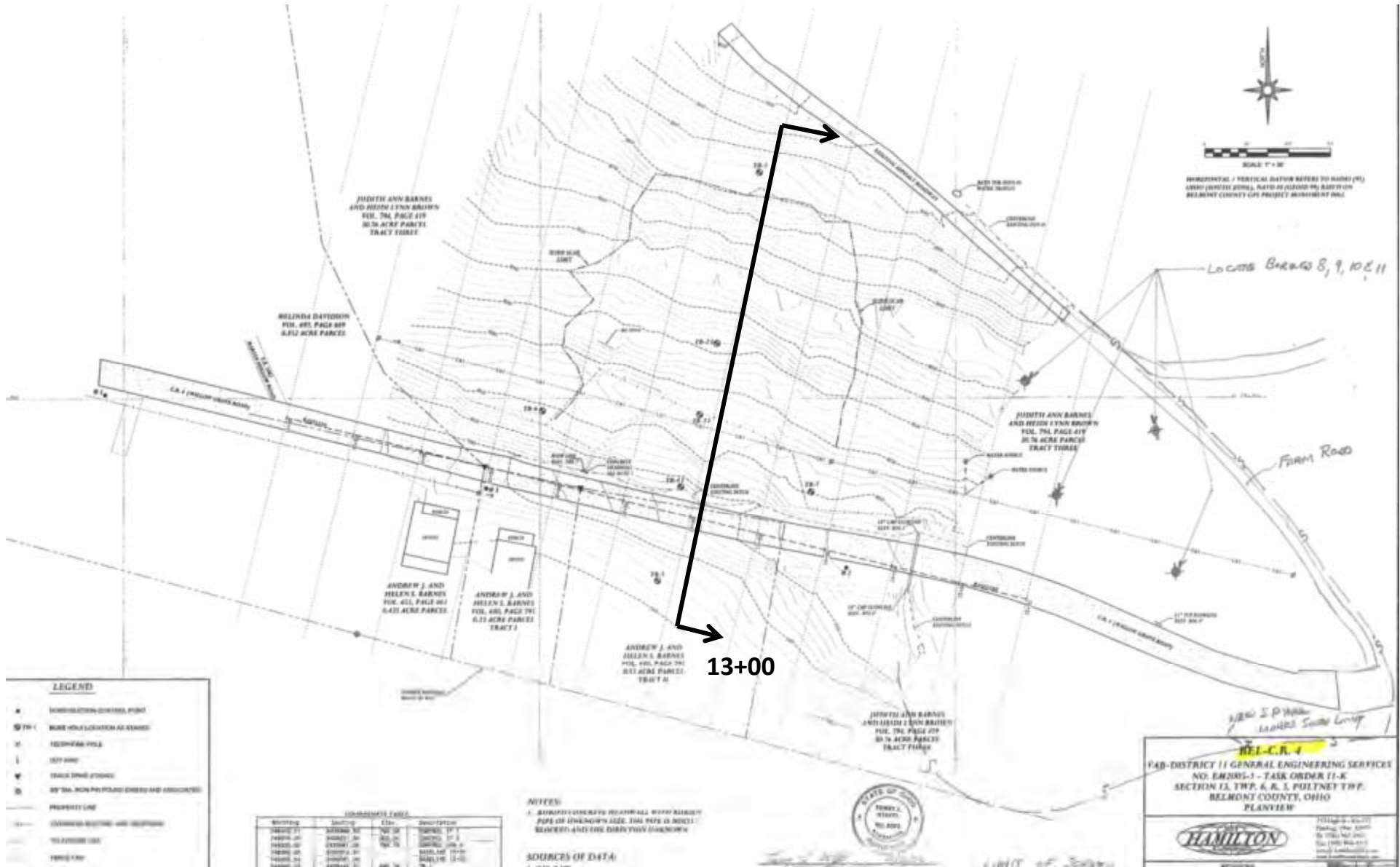

LEGEND

- SURVEILLATION CONTROL POINT
- ⊙ BUREAU OF LANDS ACRES
- FURNISHING FIELD
- SETBACK
- TRAIL (DASH) (DASH)
- ⊙ 30' DIA. NON-PERFORATED EGRESS AND ENCLOSURE
- PROPERTY LINE
- (DASH) EXISTING AND PROPOSED
- RELAYING LINE
- TRAIL (DASH)

ADJUSTMENTS TABLE

STATION	ADJUSTED	ADJUSTED	ADJUSTED	ADJUSTED
STATION 11	ADJUSTED 31	ADJUSTED 31	ADJUSTED 31	ADJUSTED 31
STATION 12	ADJUSTED 32	ADJUSTED 32	ADJUSTED 32	ADJUSTED 32
STATION 13	ADJUSTED 33	ADJUSTED 33	ADJUSTED 33	ADJUSTED 33
STATION 14	ADJUSTED 34	ADJUSTED 34	ADJUSTED 34	ADJUSTED 34

NOTES

1. SURVEILLATION POINTS SHALL BE MARKED WITH ALUMINUM PIPES OF LENGTHS AS SHOWN. THE PIPES SHALL BE BENT AND THE DIRECTION SHOWN.

SOURCES OF DATA



HEL-C.R. 4

FAD-DISTRICT 11 GENERAL ENGINEERING SERVICES
 NO. EN2005-3 - TASK ORDER 11-K
 SECTION 13, TWP. 6, R. 3, PULNEY TWP.
 BELMONT COUNTY, OHIO
 PLANVIEW

11/18/11
 11/18/11
 11/18/11
 11/18/11

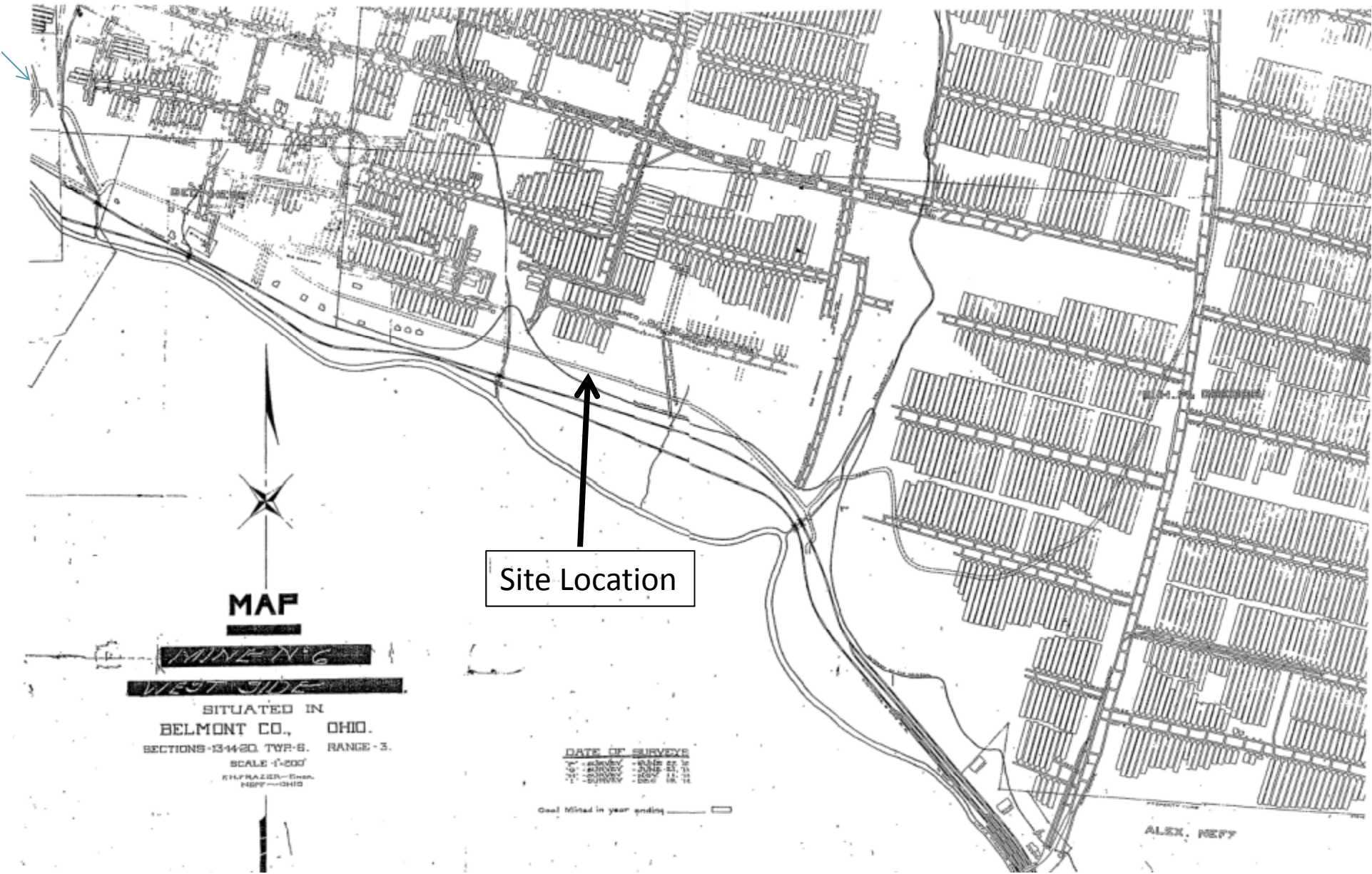

MAP

MINING

WEST SIDE

SITUATED IN
BELMONT CO., OHIO.
SECTIONS 13-14-20, TWP. 8., RANGE 3.
SCALE 1\"/>
KIMFRAZER—Engr.
NEFF—OHIO

Site Location

DATE OF SURVEYS
1870 - SURVEY - 1870
1871 - SURVEY - 1871
1872 - SURVEY - 1872

Coal mined in year ending

ALEX. NEFF

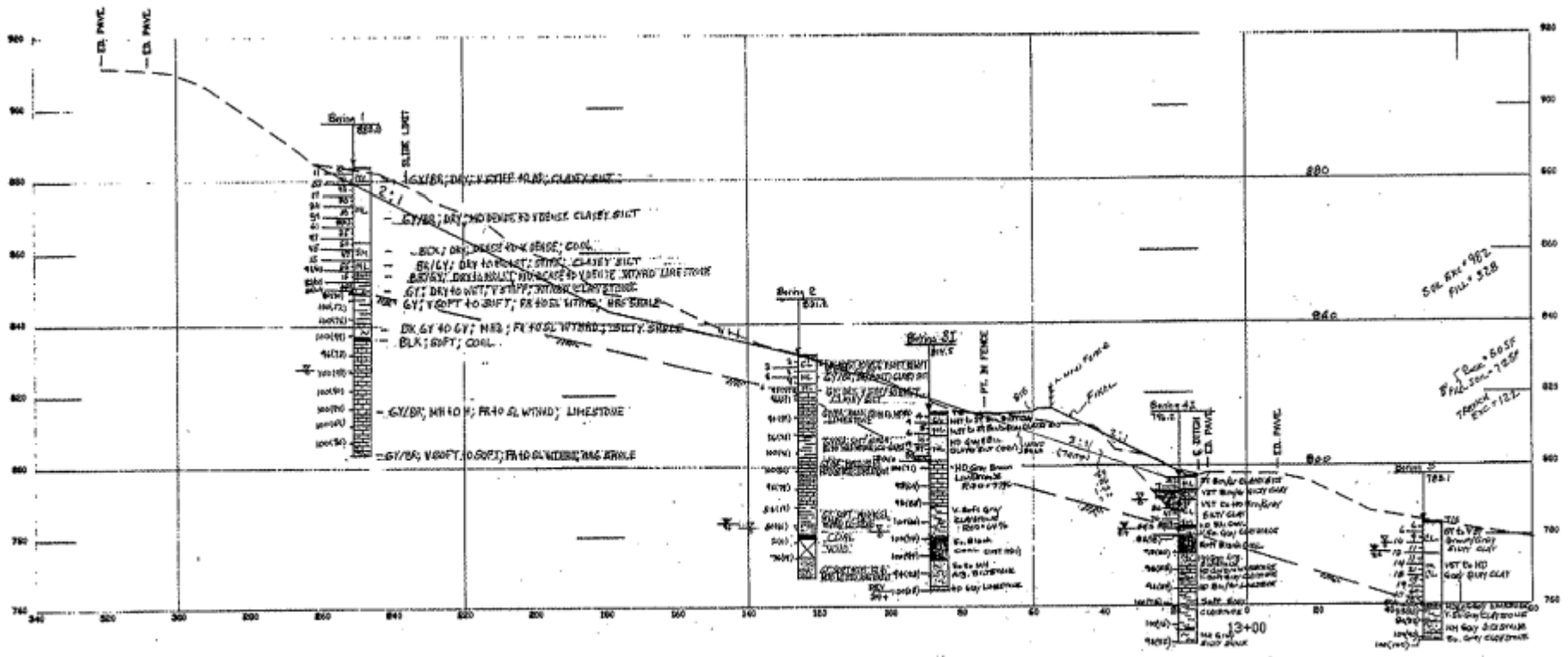

Station 13+00

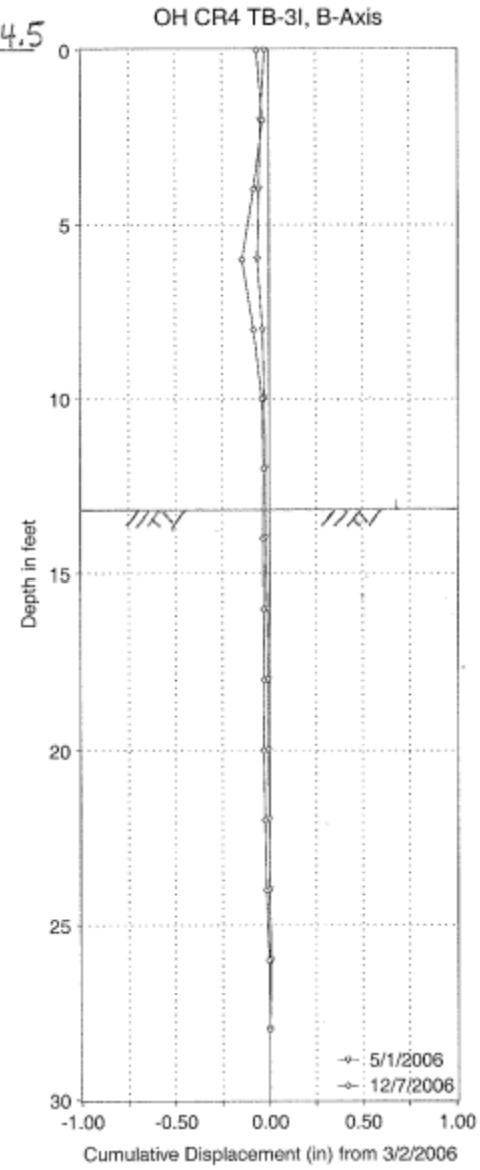
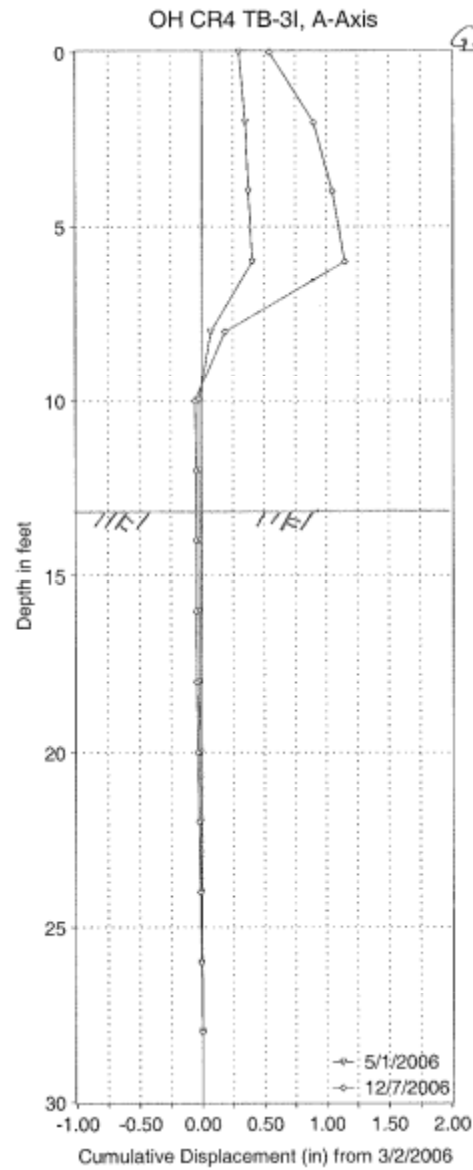

ODT CR 4 Belmont County
Embankment
Instrumentation Monitoring Program
HDR Engineering, Inc.

Inclinometer TB-3I
Initial Reading 3-2-06
Most Recent Reading 12-7-06
BOH @ 50.0 FT

BEL-CR4-7.72 Remediation Options Evaluated

Preliminary Estimate of Costs

(w 15% Contingency)

Option	Description	PEoC
1	Gabion Wall and Ditch 25' Left of CL	\$702,000
2	Grading with (Trench) Drainage in Slope	\$467,000
3	Gabion Wall 130' Left of CL	\$701,000

SCALE 1"=30'
 HORIZONTAL / VERTICAL DATUM ADJUST TO HARDENED
 GROUND (GUTTEN SCALE), AS PER RECORD PLANS BASED ON
 BELMONT COUNTY GIS PROJECT NUMBER 00101

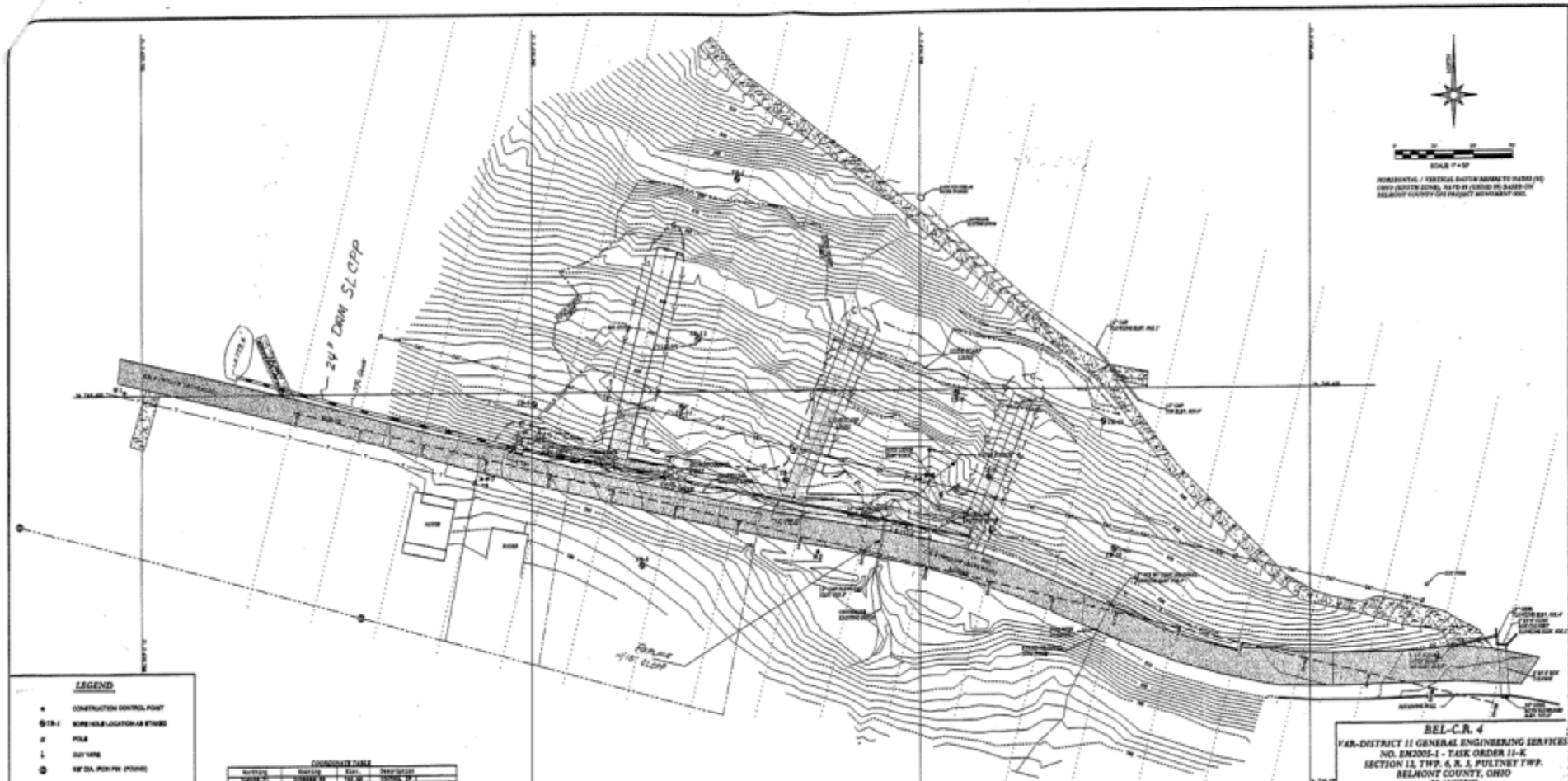

LEGEND

- CONSTRUCTION CONTROL POINT
- ⊙ BENCHMARK LOCATION STAKE
- ⊠ PILE
- ⊥ GUY WIRE
- ⊙ 8\"/>

--- PROPERTY LINE
 --- CHANGING ELECTRIC AND TELEPHONE
 --- TELEPHONE LINE AS SHOWN
 --- FENCE LINE
 [Hatched Box] EXISTING ROUGHWALL
 [Solid Box] EXISTING CONCRETE
 [Dotted Box] EXISTING ASPHALT

CONCRETE DATA

NO.	DATE	TYPE	REMARKS
1	12/15/11	12\"/>	

NOTES

1. BOWLED CONCRETE BROADWALL WITH BOWLED PIPE OF ONE FOOT DIAM. THE PIPE IS INSTALLED BENEATH AND THE DIRECTION ONE NORTH.

JOHN L. COFFEY

BEL-C.R. 4
 VAN-DETRICT II GENERAL ENGINEERING SERVICES
 NO. EM2005-1 - TASK ORDER 11-K
 SECTION 12, TWP. 6 & R. 3, PULSTNEY TWP.
 BELMONT COUNTY, OHIO
PLANVIEW

DATE: 12/15/11
 DRAWN BY: JLC
 CHECKED BY: JLC
 SCALE: AS SHOWN



Construction



























I-70 (BEL-70-22.58)











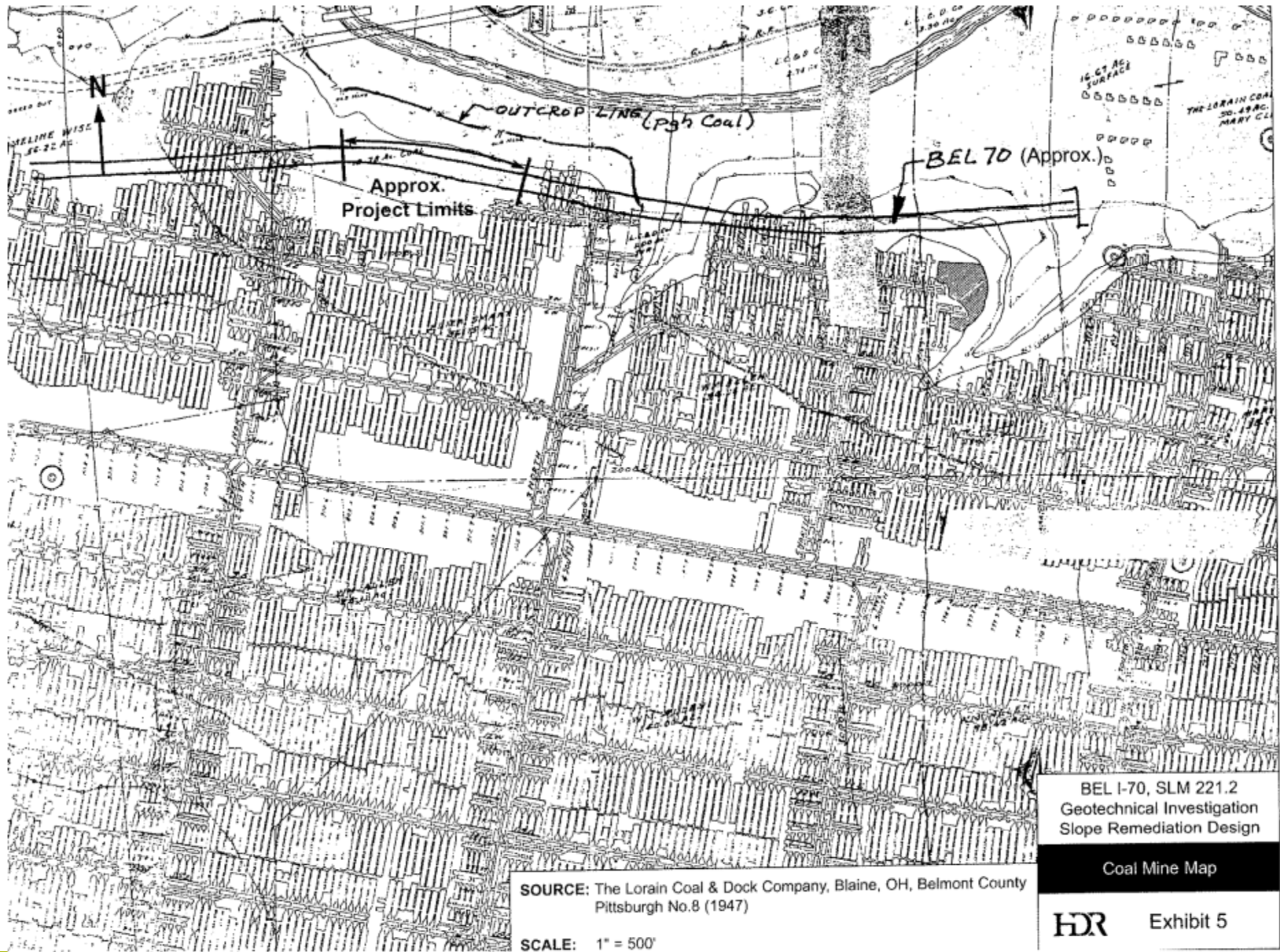

BEL I-70, SLM 221.2
Geotechnical Investigation
Slope Remediation Design

Coal Mine Map

SOURCE: The Lorain Coal & Dock Company, Blaine, OH, Belmont County
Pittsburgh No.8 (1947)

SCALE: 1" = 500'

HDR Exhibit 5

NOTES:
 1. HORIZONTAL / VERTICAL DATUM REFERS TO NAD83 (95)
 NAVD 88 (GLOID 991 OHIO (SOUTH ZONE) BASED ON
 HARN MONUMENT NEDSM&L115 PUBLISHED VALUES.
 2. CENTERLINE STATIONING AND LOCATION OF 1-70 BASED ON FOUND
 MONUMENT AT P.C. STATION 1188+12.48 AND P.O.C. STA. 1210+00.

Northing	Eastng	Elev.	Description	Station / Offset Left
756401.52	2439137.10	921.21	CONTROL SP #1	1200+62.30 / 58.02'LT
756565.05	2438325.82	965.84	CONTROL SP #2	1192+44.55 / 72.61'LT

LEGEND

- TEST BORING LOCATION
- TEST BORING LOCATION WITH INCLINOMETER
- 50/0.4
30
SPT-N-VALUES/PORTION OF A FOOT
- 100/160
96/180
SPT-N-VALUES BASED ON ONE (10) FOOT
ROD & PER CORE RUN
& CORE RECOVERY

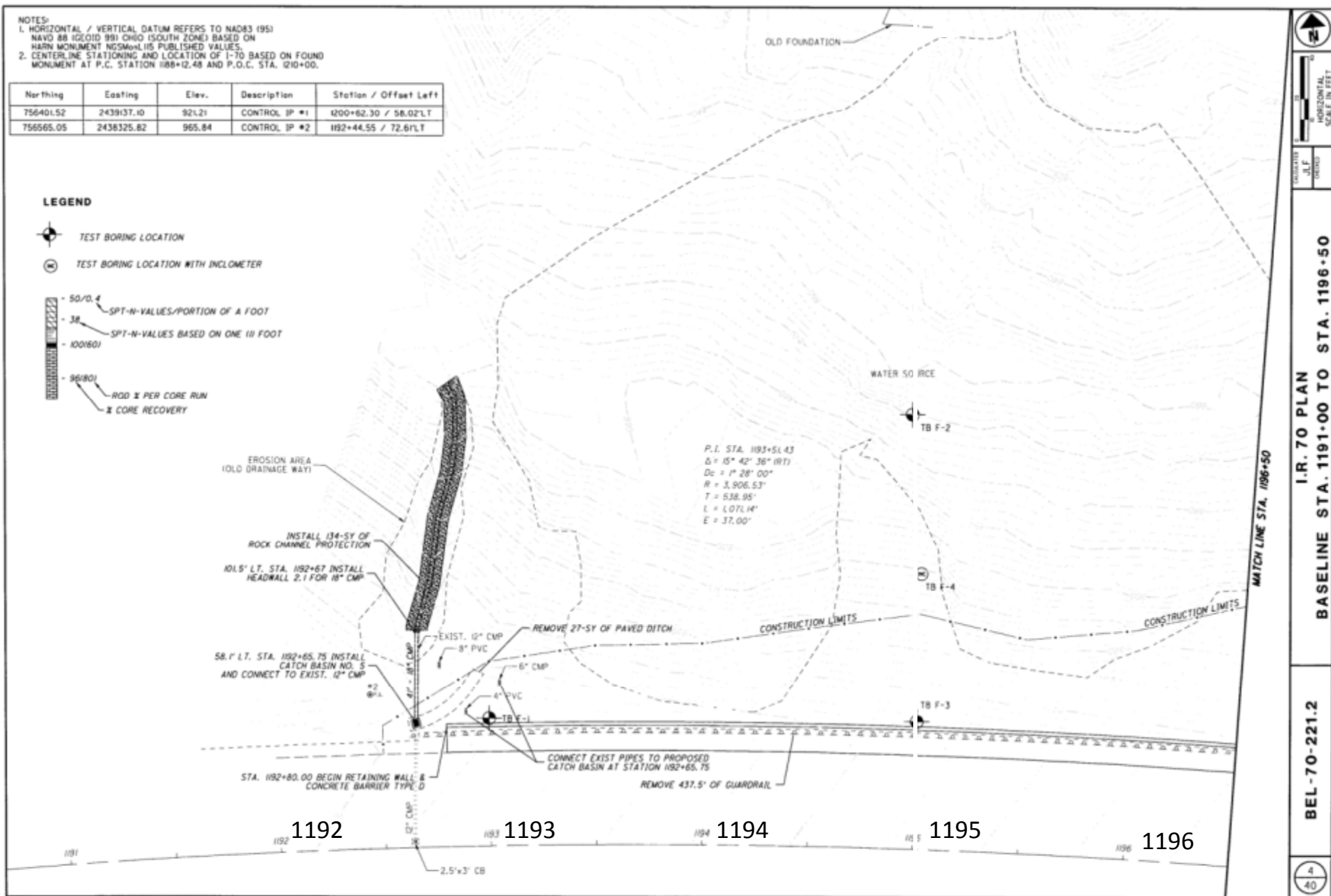

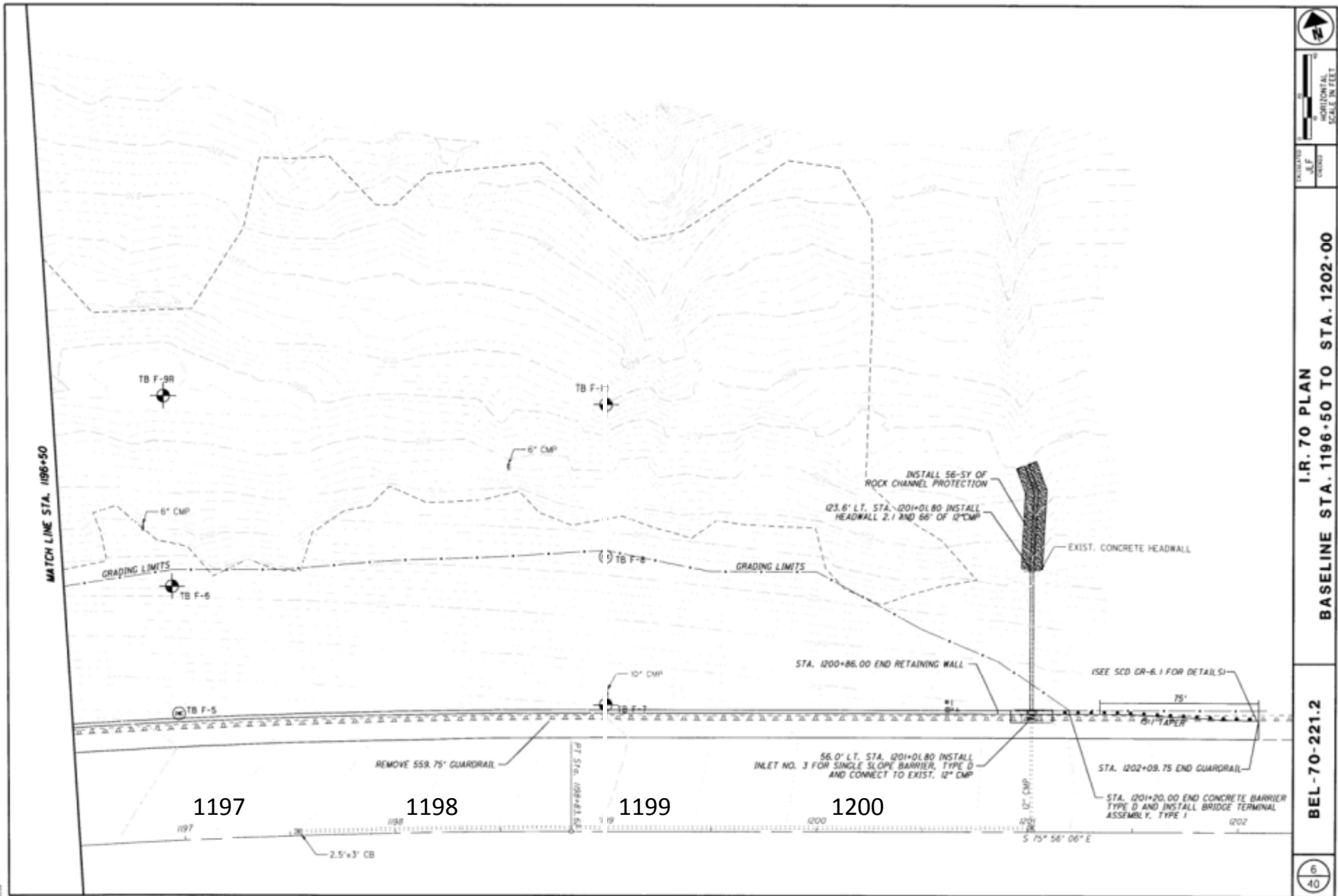

I.R. 70 PLAN
BASELINE STA. 1196+50 TO STA. 1202+00

BEL-70-221.2

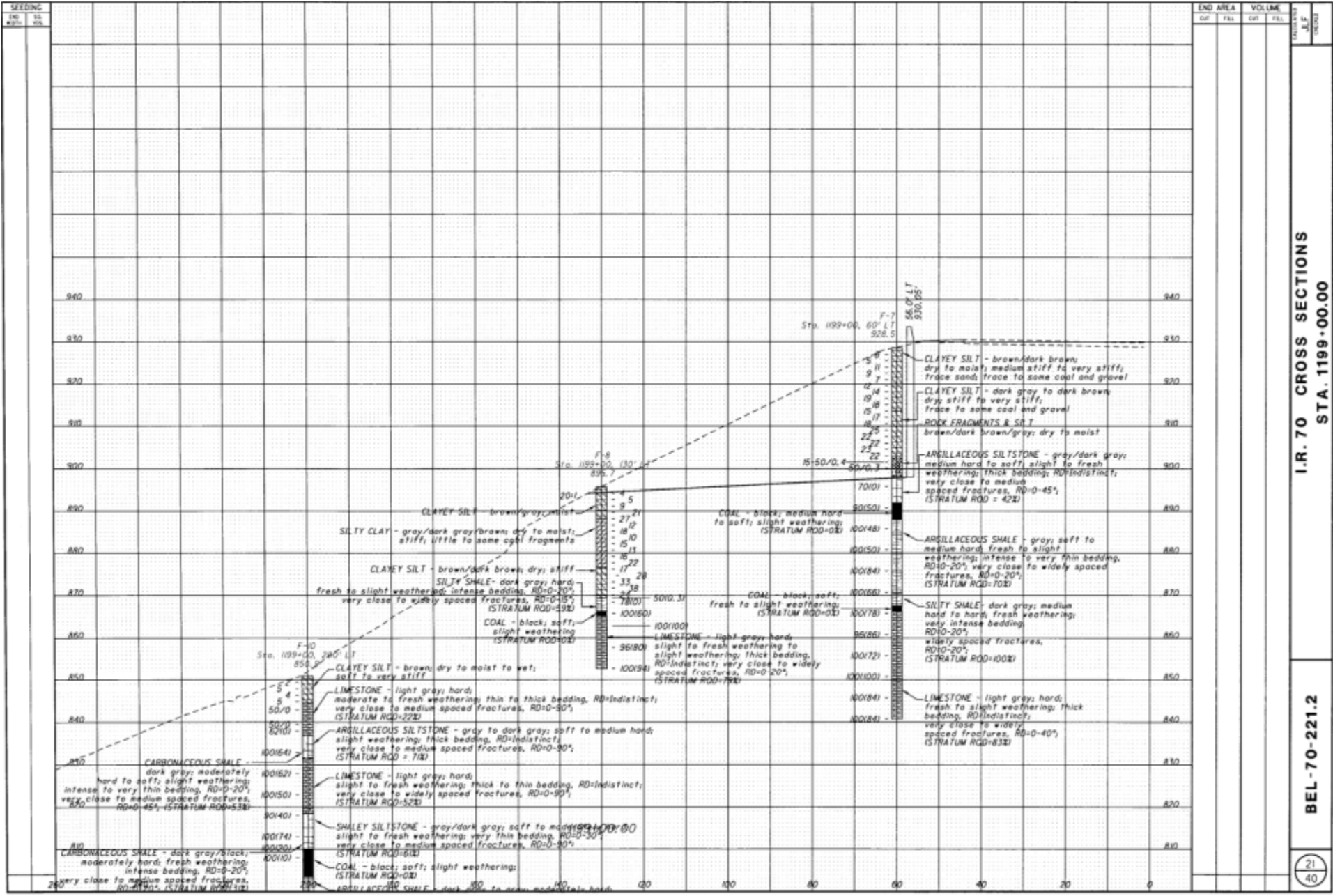

I.R. 70 CROSS SECTIONS
STA. 1199+00.00

BEL 70-221.2

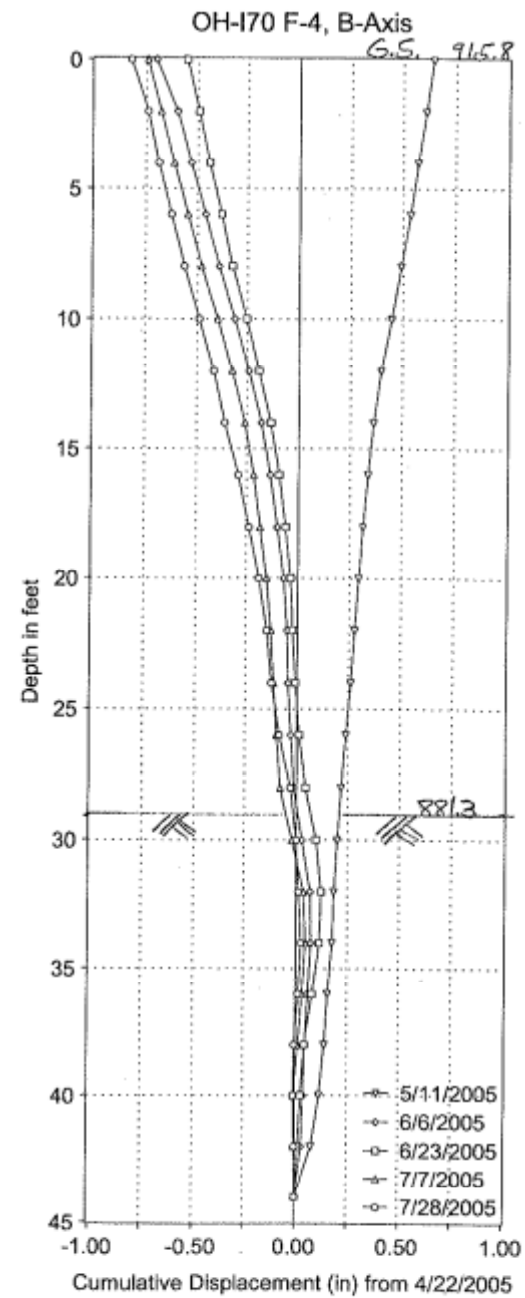
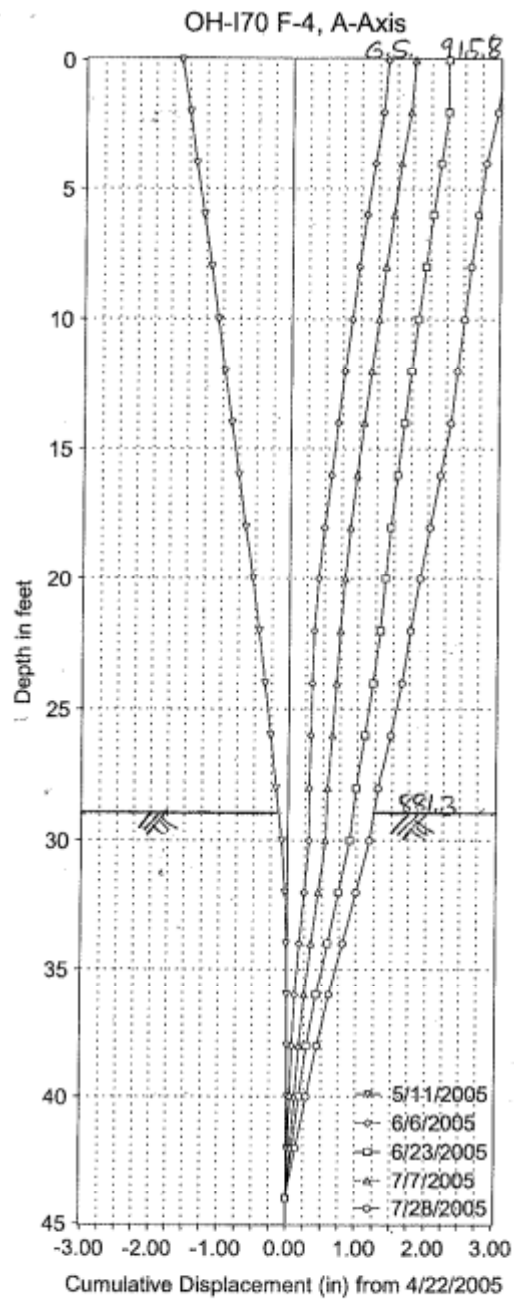

BEL-70-22.58

Remediation Options Considered

- Option 1 - Anchored Soldier Pile Wall (ASPW)
- Option 2 - Soil Nail Wall (SNW)
- Option 3 - Regrade and Repair with Rock Embankment (R&R w RE)

Also Considered

- Insert Wall
- Anchored, Tangent Drilled Shaft Wall

Option 2 – SNW - Plan View

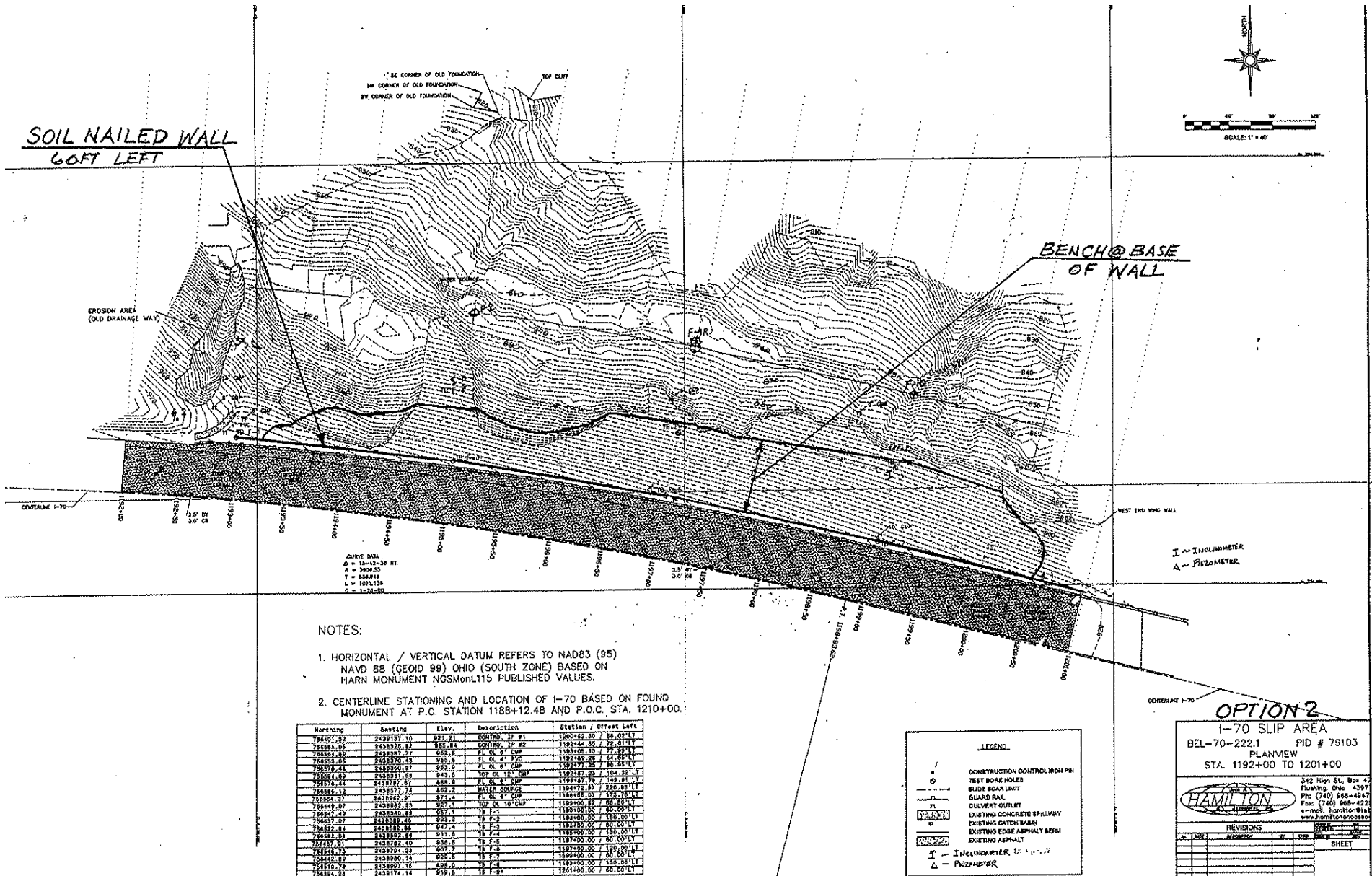

Option 2 – SNW –1195+00

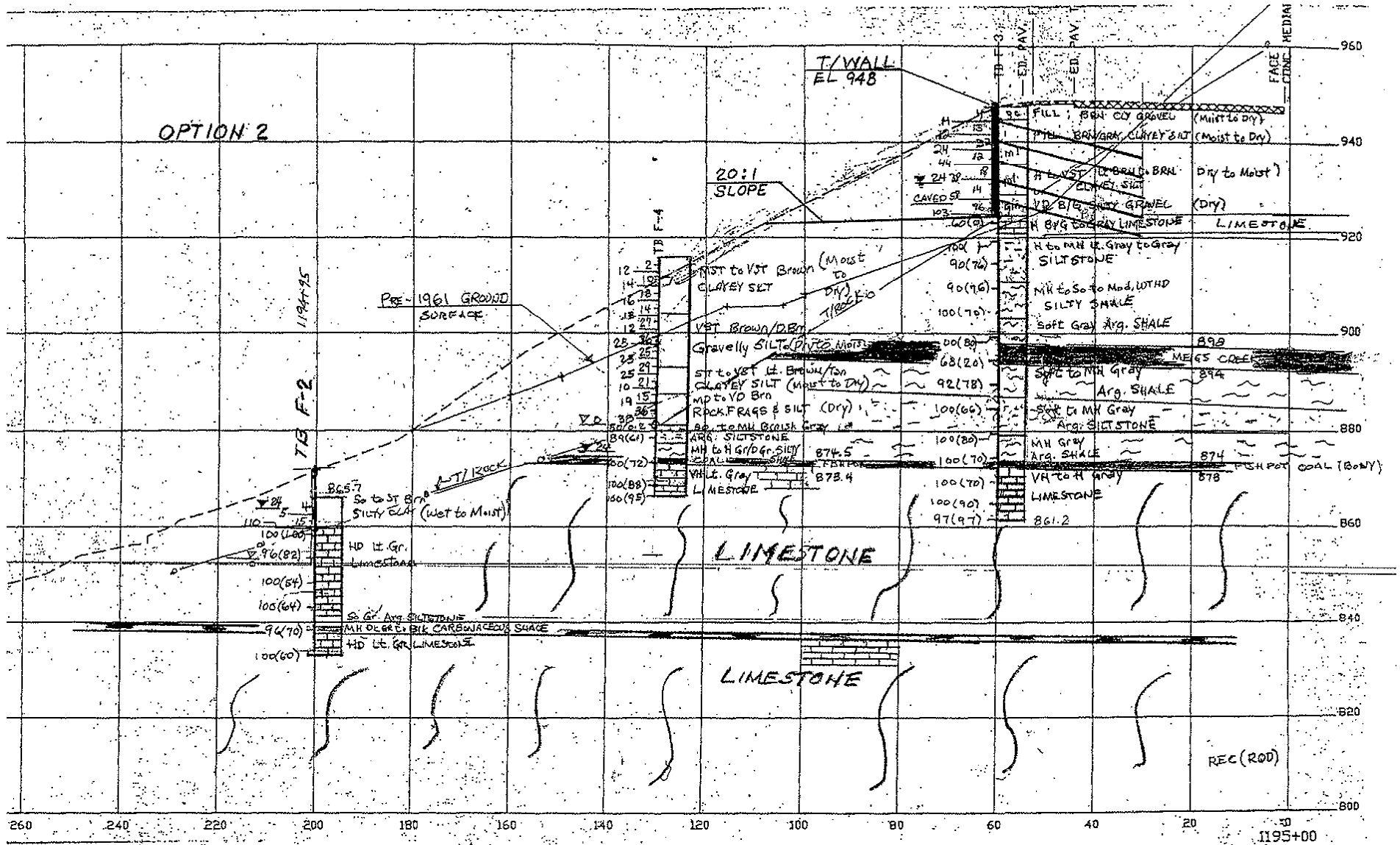

IR.
I. LANE

Option 3 – R&R w RE –1195+00

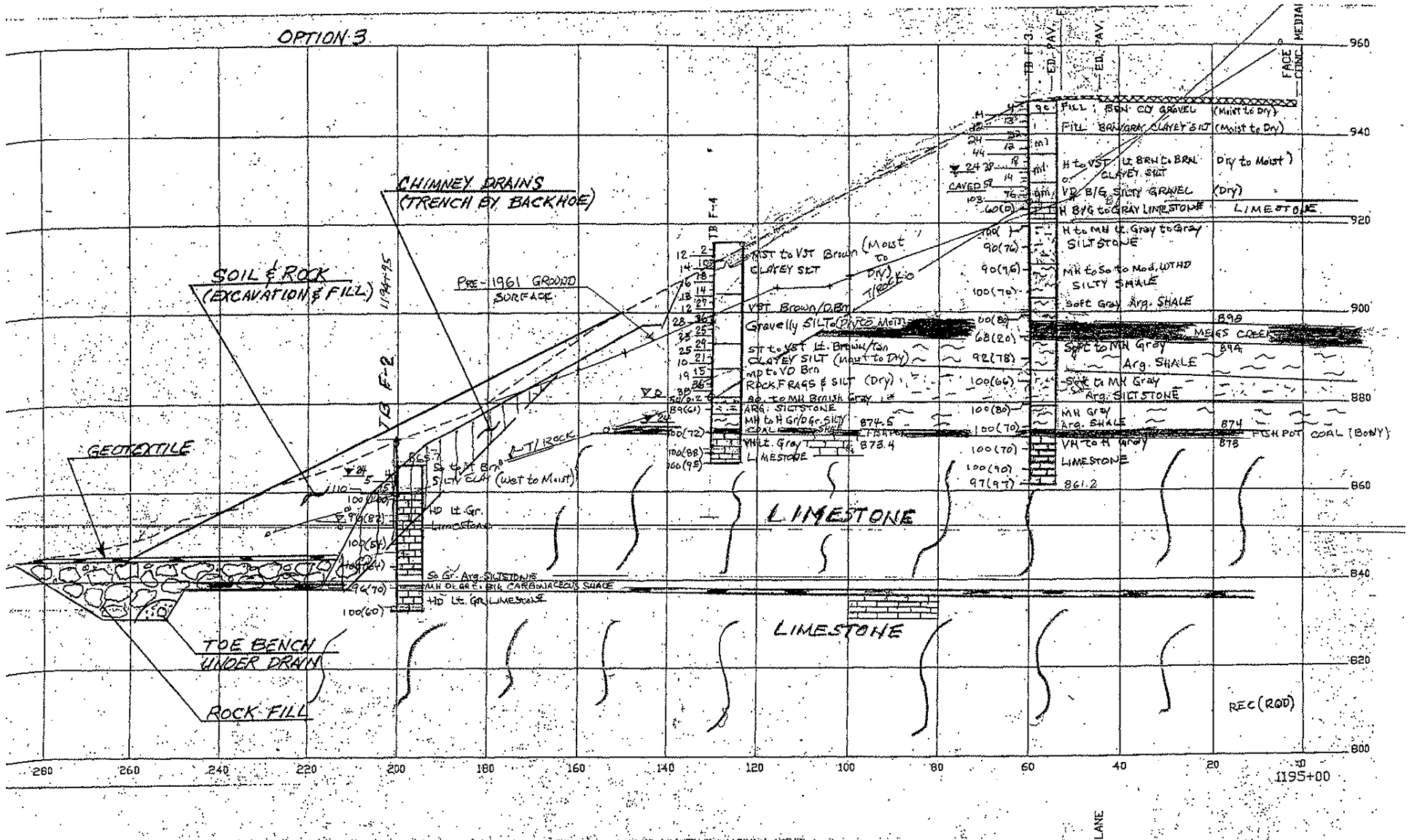

BEL-70-22.58 Remediation Options Evaluated Preliminary Estimate of Costs (w 15% Contingency)

Option	Description	PEoC
1	Anchored Soldier Pile Wall (ASPW)	\$2,400,000
2	Soil Nail Wall (SNW)	\$1,850,000
3	Remove & Replace w Rock Embankment	\$1,850,000

BEL-70-22.58

Remediation Options Evaluated Key Considerations

Option	Description	Cost	Risk (ST and LT)	Constructibility
1	ASPW	Highest	Low	Relatively Common
2	SNW	Low(1)	Low	Specialty Exp Required
3	R&R w RE	Low	High	Difficult

Notes:

1 – Possible variability due to requirement for specialty experience.

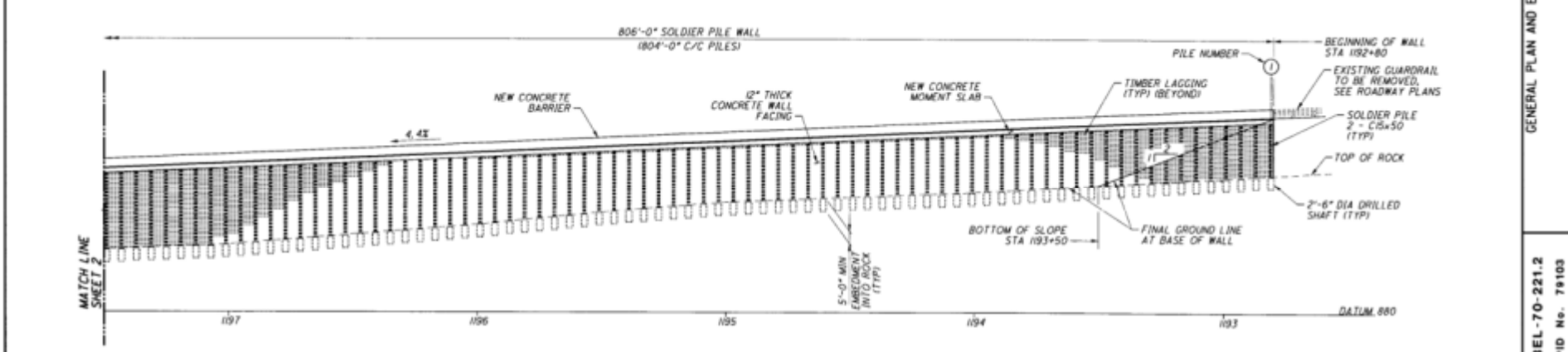
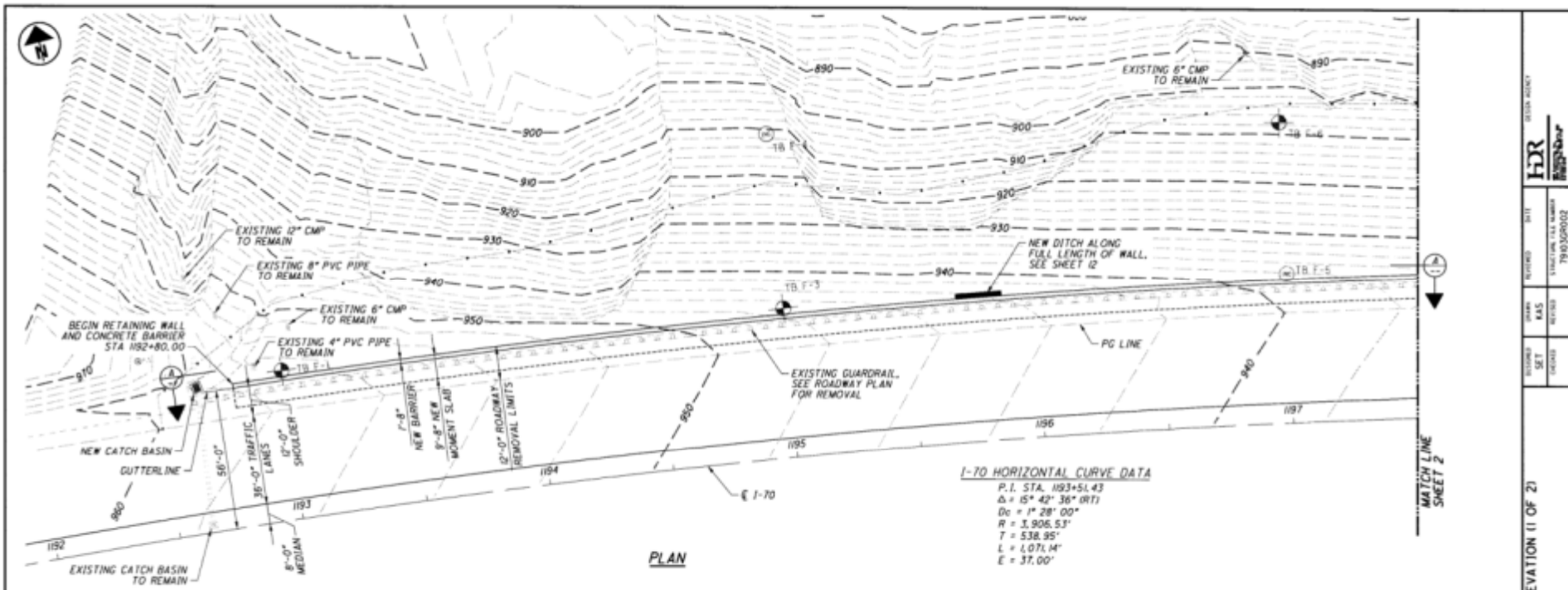

NOTES:
 1. SEE SHEET 3 FOR GENERAL NOTES.

GENERAL PLAN AND ELEVATION (1 OF 2)

BEL-70-221.2
 PID No. 79103

1 / 14
 27 / 40

REVISIONS:
 DATE: KAS
 BY: KAS
 SET: SET
 REVISION: 791030002

HR
 HERRINGTON

PILE LOCATIONS AND ANCHOR ELEVATIONS

PILE	STATION	OFFSET TO PILE	PG ELEVATION	GUTTERLINE ELEVATION	TOP OF PILE ELEVATION	ANCHOR ROW 's'	ANCHOR ROW 's'	ANCHOR ROW 's'	ESTIMATED ROCK ELEVATION	ESTIMATED DRILLED SHAFT LENGTH **
1	192+81	55'-0"	958.57	958.09	955.46	-	-	-	935.14	5.00
2	192+87	55'-0"	958.30	957.82	955.20	-	-	-	934.78	5.00
3	192+93	55'-0"	958.04	957.56	954.94	-	-	-	934.42	5.00
4	192+99	55'-0"	957.77	957.29	954.67	949.58	-	-	934.06	5.00
5	193+05	55'-0"	957.51	957.03	954.40	949.31	-	-	933.70	5.00
6	193+11	55'-0"	957.24	956.76	954.13	949.04	-	-	933.34	5.00
7	193+17	55'-0"	956.97	956.49	953.87	948.78	938.49	-	932.98	5.00
8	193+23	55'-0"	956.70	956.22	953.60	948.51	-	-	932.62	5.00
9	193+29	55'-0"	956.44	955.96	953.33	948.24	938.22	-	932.26	5.00
10	193+35	55'-0"	956.17	955.69	953.06	947.97	938.00	-	931.90	5.00
11	193+41	55'-0"	955.90	955.42	952.80	947.70	937.78	-	931.54	5.00
12	193+47	55'-0"	955.63	955.15	952.53	947.43	937.56	-	931.18	5.00
13	193+53	55'-0"	955.37	954.89	952.26	947.16	937.34	-	930.82	5.00
14	193+59	55'-0"	955.10	954.62	952.00	946.89	937.12	-	930.46	5.00
15	193+65	55'-0"	954.83	954.35	951.73	946.62	936.90	-	930.10	5.00
16	193+71	55'-0"	954.57	954.09	951.46	946.35	936.68	-	929.74	5.00
17	193+77	55'-0"	954.30	953.82	951.20	946.08	936.46	-	929.38	5.00
18	193+83	55'-0"	954.03	953.55	950.93	945.81	936.24	-	929.02	5.00
19	193+89	55'-0"	953.77	953.29	950.66	945.54	936.02	-	928.66	5.00
20	193+95	55'-0"	953.50	953.02	950.40	945.27	935.80	-	928.30	5.00
21	194+01	55'-0"	953.24	952.76	950.13	945.00	935.58	-	927.94	5.00
22	194+07	55'-0"	952.97	952.49	949.86	944.73	935.36	-	927.58	5.00
23	194+13	55'-0"	952.70	952.22	949.59	944.46	935.14	-	927.22	5.00
24	194+19	55'-0"	952.43	951.95	949.32	944.19	934.92	-	926.86	5.00
25	194+25	55'-0"	952.16	951.68	949.05	943.92	934.70	-	926.50	5.00
26	194+31	55'-0"	951.89	951.41	948.78	943.65	934.48	-	926.14	5.00
27	194+37	55'-0"	951.62	951.14	948.51	943.38	934.26	-	925.78	5.00
28	194+43	55'-0"	951.35	950.87	948.24	943.11	934.04	-	925.42	5.00
29	194+49	55'-0"	951.08	950.60	947.97	942.84	933.82	-	925.06	5.00
30	194+55	55'-0"	950.80	950.33	947.70	942.57	933.60	-	924.70	5.00
31	194+61	55'-0"	950.53	950.05	947.43	942.30	933.38	-	924.34	5.00
32	194+67	55'-0"	950.26	949.78	947.16	942.03	933.16	-	923.98	5.00
33	194+73	55'-0"	949.99	949.51	946.89	941.76	932.94	-	923.62	5.00
34	194+79	55'-0"	949.72	949.24	946.62	941.49	932.72	-	923.26	5.00
35	194+85	55'-0"	949.45	948.97	946.35	941.22	932.50	-	922.90	5.00
36	194+91	55'-0"	949.18	948.70	946.08	940.95	932.28	-	922.54	5.00
37	194+97	55'-0"	948.91	948.43	945.81	940.68	932.06	-	922.18	5.00
38	195+03	55'-0"	948.63	948.15	945.54	940.41	931.84	-	921.82	5.00
39	195+09	55'-0"	948.36	947.88	945.27	940.14	931.62	-	921.46	5.00
40	195+15	55'-0"	948.09	947.61	945.00	939.87	931.40	-	921.10	5.00
41	195+21	55'-0"	947.82	947.34	944.72	939.60	931.18	-	920.74	5.00
42	195+27	55'-0"	947.55	947.07	944.45	939.33	930.96	-	920.38	5.00
43	195+33	55'-0"	947.28	946.80	944.17	939.06	930.74	-	920.02	5.00
44	195+39	55'-0"	947.01	946.53	943.90	938.79	930.52	-	919.66	5.00
45	195+45	55'-0"	946.74	946.26	943.63	938.52	930.30	-	919.30	5.00
46	195+51	55'-0"	946.47	945.99	943.36	938.25	930.08	-	918.94	5.00
47	195+57	55'-0"	946.20	945.72	943.09	937.98	929.86	-	918.58	5.00
48	195+63	55'-0"	945.93	945.45	942.82	937.71	929.64	-	918.22	5.00
49	195+69	55'-0"	945.66	945.18	942.55	937.44	929.42	-	917.86	5.00
50	195+75	55'-0"	945.39	944.90	942.28	937.17	929.20	-	917.50	5.00
51	195+81	55'-0"	945.12	944.63	942.01	936.90	928.98	-	917.14	5.00
52	195+87	55'-0"	944.85	944.36	941.73	936.63	928.76	-	916.78	5.00
53	195+93	55'-0"	944.58	944.09	941.46	936.36	928.54	-	916.42	5.00
54	195+99	55'-0"	944.31	943.82	941.19	936.09	928.32	-	916.06	5.00
55	196+05	55'-0"	944.03	943.55	940.92	935.82	928.10	-	915.70	5.00
56	196+11	55'-0"	943.76	943.27	940.65	935.55	927.88	-	915.34	5.00
57	196+17	55'-0"	943.49	943.00	940.38	935.28	927.66	-	914.98	5.00
58	196+23	55'-0"	943.22	942.73	940.11	935.01	927.44	-	914.62	5.00
59	196+29	55'-0"	942.95	942.46	939.84	934.74	927.22	-	914.26	5.00
60	196+35	55'-0"	942.68	942.19	939.57	934.47	927.00	-	913.90	5.00
61	196+41	55'-0"	942.41	941.92	939.30	934.20	926.78	-	913.54	5.00
62	196+47	55'-0"	942.14	941.65	939.03	933.93	926.56	-	913.18	5.00
63	196+53	55'-0"	941.87	941.38	938.76	933.66	926.34	-	912.82	5.00
64	196+59	55'-0"	941.60	941.11	938.49	933.39	926.12	-	912.46	5.00
65	196+65	55'-0"	941.33	940.84	938.22	933.12	925.90	-	912.10	5.00
66	196+71	55'-0"	941.06	940.57	937.95	932.85	925.68	-	911.74	5.00
67	196+77	55'-0"	940.79	940.30	937.68	932.58	925.46	-	911.38	5.00
68	196+83	55'-0"	940.52	940.03	937.41	932.31	925.24	-	911.02	5.00
69	196+89	55'-0"	940.25	939.76	937.14	932.04	925.02	-	910.66	5.00
70	196+95	55'-0"	940.00	939.50	936.87	931.77	924.80	-	910.30	5.00
71	197+01	55'-0"	939.73	939.23	936.60	931.50	924.58	-	909.94	5.00
72	197+07	55'-0"	939.46	938.96	936.33	931.23	924.36	-	909.58	5.00
73	197+13	55'-0"	939.19	938.69	936.06	930.96	924.14	-	909.22	5.00
74	197+19	55'-0"	938.92	938.42	935.79	930.69	923.92	-	908.86	5.00
75	197+25	55'-0"	938.65	938.15	935.52	930.42	923.70	-	908.50	5.00
76	197+31	55'-0"	938.38	937.88	935.25	930.15	923.48	-	908.14	5.00
77	197+37	55'-0"	938.11	937.61	934.98	929.88	923.26	-	907.78	5.00

PILE LOCATIONS AND ANCHOR ELEVATIONS (CONT)

PILE	STATION	OFFSET TO PILE	PG ELEVATION	GUTTERLINE ELEVATION	TOP OF PILE ELEVATION	ANCHOR ROW 's'	ANCHOR ROW 's'	ANCHOR ROW 's'	ESTIMATED ROCK ELEVATION	ESTIMATED DRILLED SHAFT LENGTH **
78	197+43	55'-0"	937.84	937.36	934.71	929.61	923.04	916.99	907.59	5.00
79	197+49	55'-0"	937.57	937.09	934.44	929.34	922.82	916.77	907.37	5.00
80	197+55	55'-0"	937.30	936.82	934.17	929.07	922.60	916.55	907.15	5.00
81	197+61	55'-0"	937.03	936.55	933.90	928.80	922.38	916.33	906.93	5.00
82	197+67	55'-0"	936.76	936.28	933.63	928.53	922.16	916.11	906.71	5.00
83	197+73	55'-0"	936.49	936.01	933.36	928.26	921.94	915.89	906.49	5.00
84	197+79	55'-0"	936.22	935.74	933.09	927.99	921.72	915.67	906.27	5.00
85	197+85	55'-0"	935.95	935.47	932.82	927.72	921.50	915.45	906.05	5.00
86	197+91	55'-0"	935.68	935.20	932.55	927.45	921.28	915.23	905.83	5.00
87	197+97	55'-0"	935.41	934.93	932.28	927.18	921.06	915.01	905.61	5.00
88	198+03	55'-0"	935.14	934.66	932.01	926.91	920.84	914.79	905.39	5.00
89	198+09	55'-0"	934.87	934.39	931.74	926.64	920.62	914.57	905.17	5.00
90	198+15	55'-0"	934.60	934.12	931.47	926.37	920.40	914.35	904.95	5.00
91	198+21	55'-0"	934.33	933.85	931.20	926.10	920.18	914.13	904.73	5.00
92	198+27	55'-0"	934.06	933.58	930.93	925.83	919.96	913.91	904.51	5.00
93	198+33	55'-0"	933.79	933.31	930.66	925.56	919.74	913.69	904.29	5.00
94	198+39	55'-0"	933.52	933.04	930.39	925.29	919.52	913.47	904.07	5.00
95	198+45	55'-0"	933.25	932.77	930.12	925.02	919.30	913.25	903.85	5.00
96	198+51	55'-0"	932.98	932.50	929.85	924.75	919.08	913.03	903.63	5.00
97	198+57	55'-0"	932.71	932.23	929.58	924.48	918.86	912.81	903.41	5.00
98	198+63	55'-0"	932.44	931.96	929.31	924.21	918.64	912.59	903.19	5.00
99	198+69	55'-0"	932.17	931.69	929.04	923.94	918.42	912.37	902.97	5.00
100	198+75	55'-0"	931.90	931.42	928.77	923.67	918.20	912.15	902.75	5.00
101	198+81	55'-0"	931.63	931.15	928.50	923.40	917.98	911.93	902.53	5.00
102	198+87	55'-0"	931.36	930.88	928.23	923.13	917.76	911.71	902.31	5.00
103	198+93	55'-0"	931.09	930.61	927.96	922.86	917.54	911.49	902.09	5.00
104	198+99	55'-0"	930.82	930.34	927.69	922.59	917.32	911.27	901.87	5.00
105	199+05	55'-0"	930.55	930.07	927.42	922.32	917.10	911.05	901.65	5.00
106	199+11	55'-0"	930.28	929.80	927.15					

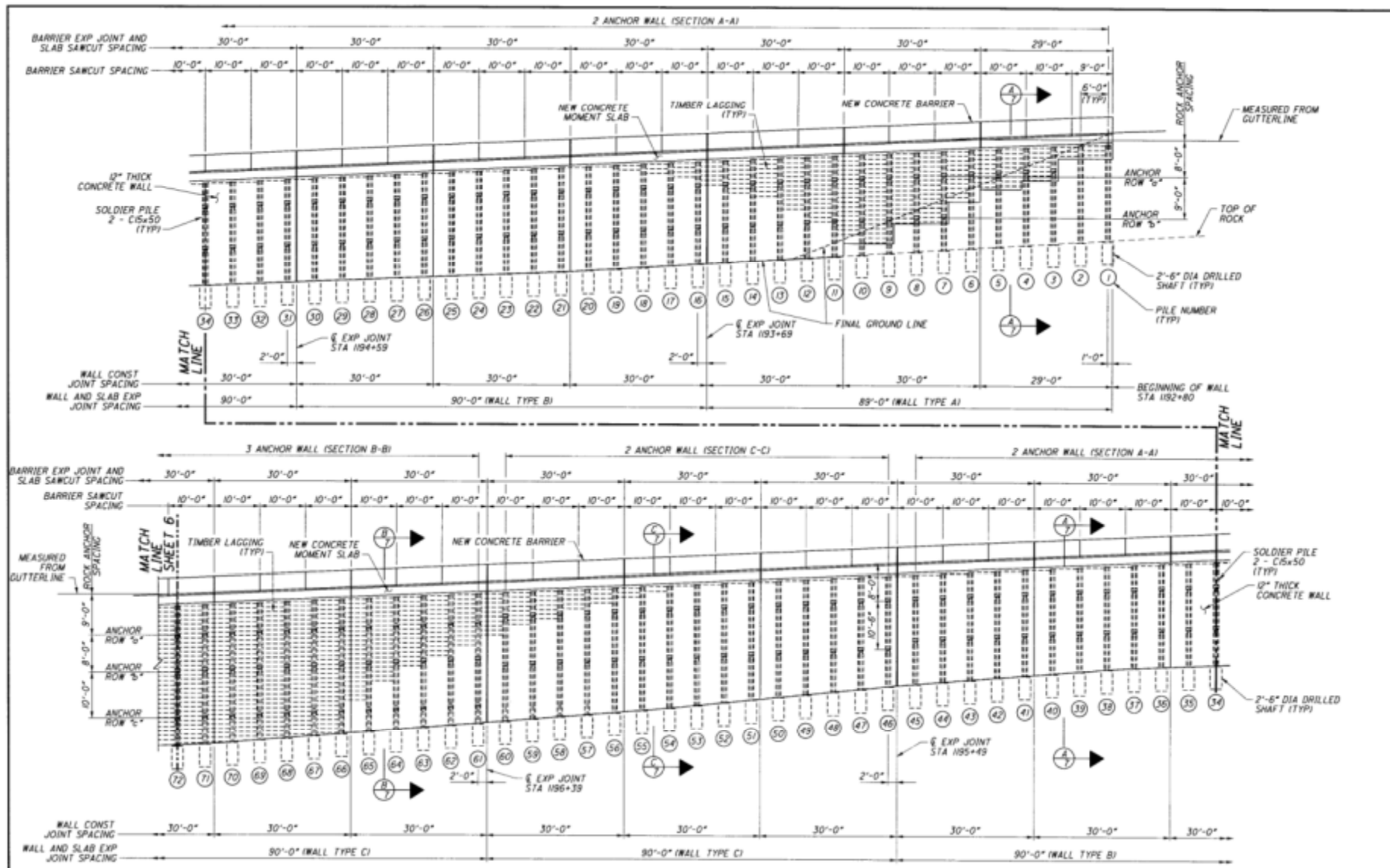

ELEVATION

- NOTES:**
1. SEE SHEET 3 FOR GENERAL NOTES.
 2. SEE SHEET 13 FOR WALL EXPANSION AND CONSTRUCTION JOINT DETAILS.

DESIGN AGENCY		DATE	
PROJECT NAME		PROJECT NO.	
ISSUED	REVISED	DATE	BY
SET	NO.		
WALL ELEVATION (1 OF 2)			
BEL-70-221.2		PID No. 78103	
5 / 14		31	
40			

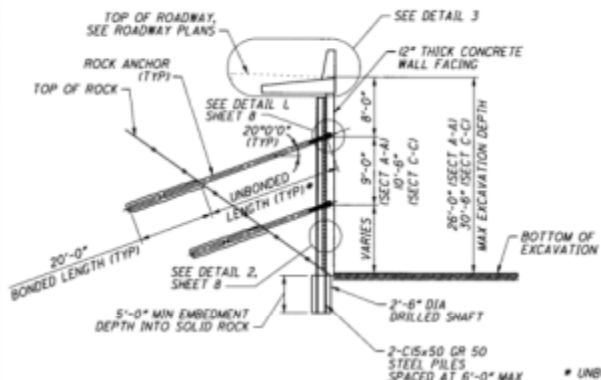

SECTION A-A (AS SHOWN AND NOTED)
SECTION C-C (AS SHOWN AND NOTED)
2 ANCHOR WALL

* UNBOND ANCHOR FROM ANCHOR HEAD TO ROCK FACE. MINIMUM UNBONDED LENGTH IS 15'-0". UNBOND ANCHOR PAST FACE OF ROCK TO ACHIEVE 15'-0" MINIMUM UNBONDED LENGTH WHERE NECESSARY.

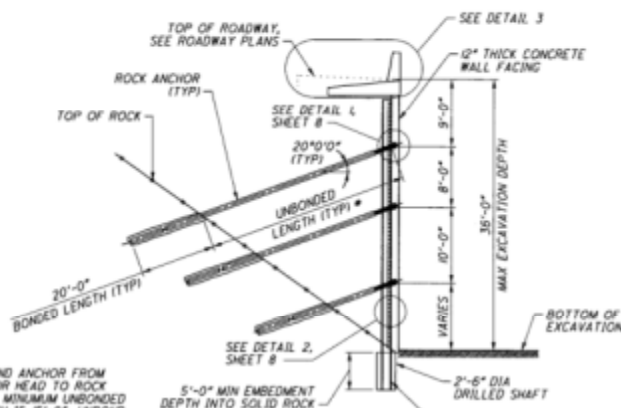

SECTION B-B
3 ANCHOR WALL

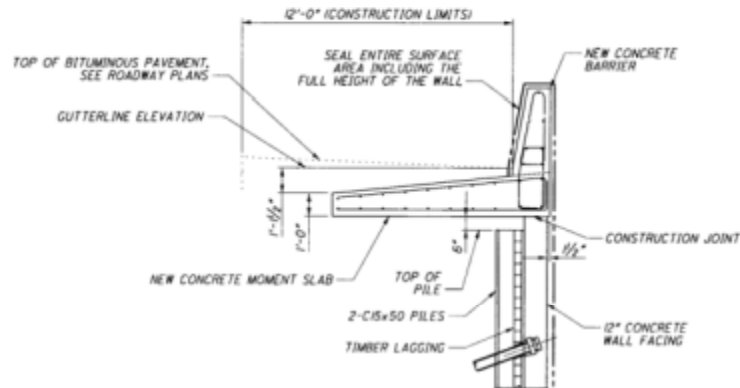

DETAIL 3
 (FOR DIMENSIONS NOT SHOWN, SEE SECTION M-M, SHEET 12)

ANCHOR LOADS						
ANCHOR ROW	SECTION A-A TO MAX 25'-0" HEIGHT		SECTION B-B		SECTION C-C WALL HEIGHT 26'-6" TO 30'-6"	
	LOCK-OFF LOAD	PROOF LOAD	LOCK-OFF LOAD	PROOF LOAD	LOCK-OFF LOAD	PROOF LOAD
ROW 1*	202 KIPS	230 KIPS	226 KIPS	260 KIPS	222 KIPS	231 KIPS
ROW 2*	089 KIPS	230 KIPS	91 KIPS	145 KIPS	234 KIPS	270 KIPS
ROW 3*	-	-	227 KIPS	280 KIPS	-	-

* 12 ANCHOR WALL * 13 ANCHOR WALL * 12 ANCHOR WALL - 30.5'

NOTES:

- SEE SHEET 3 FOR GENERAL NOTES
- BEARING PLATE SHALL BE COUNTERBORED TO RECEIVE THE ANCHOR HEAD AND SHALL BE FURNISHED BY THE ANCHOR HEAD MANUFACTURER.
- PREBORED HOLE SHALL BE OF LARGE ENOUGH SIZE TO CLEAR THE SOLDIER PILE. HOWEVER IT SHALL NOT BE LESS THAN 30" DIAMETER.
- WALL SECTIONS A-A, B-B AND C-C SHOWN ARE FOR FULL HEIGHT WALLS CONSTRUCTED DOWN TO TOP OF ROCK. FOR THE PORTIONS OF WALL THAT ARE STEPPED (AT THE BEGINNING AND END OF WALL) ONLY INSTALL ANCHORS, LAGGING AND FACING DOWN TO THE LEVEL SHOWN ON THE WALL ELEVATIONS.

TYPICAL WALL SECTIONS (1 OF 2)

BEL-70-221.2
 PID No. 79103

7 14

33
 40

DESIGNED BY: SET
 CHECKED BY:
 DRAWN BY: KAS
 REVIEWED BY:
 DATE:
 REVISIONS:
 BEL-70-221.2
 STRUCTURAL FILE NUMBER
 PHOTOBOOK

HR
 HERRING
 CONSULTANTS

BLANK SHEET

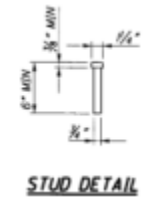
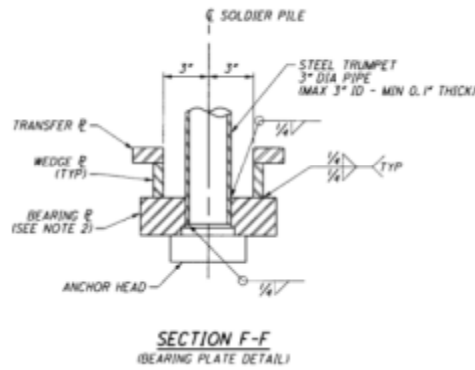
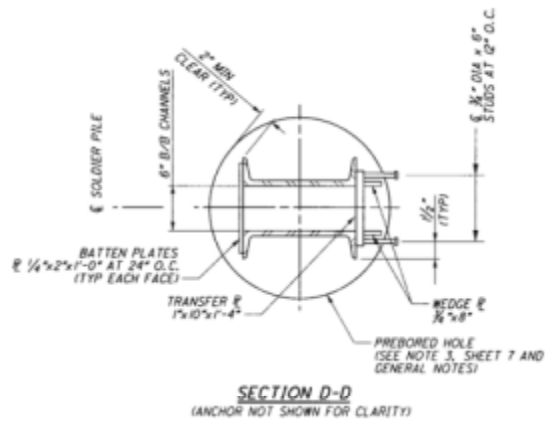
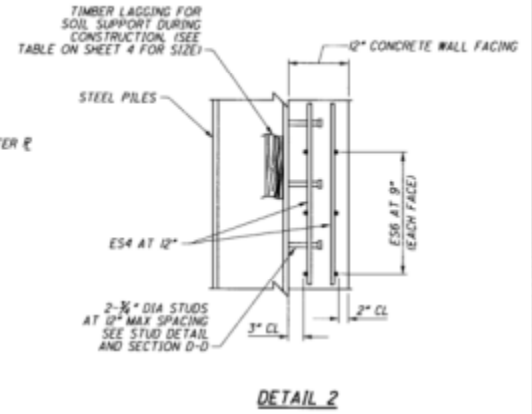
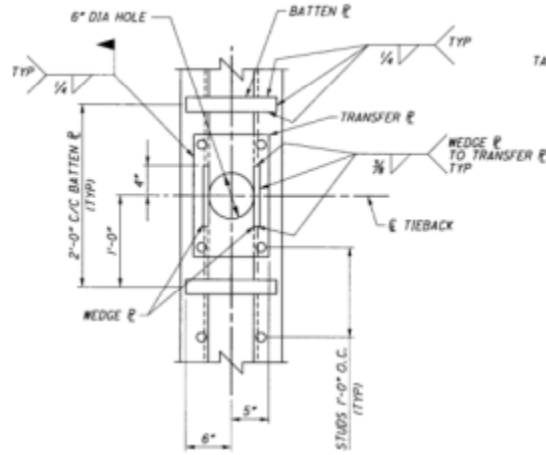
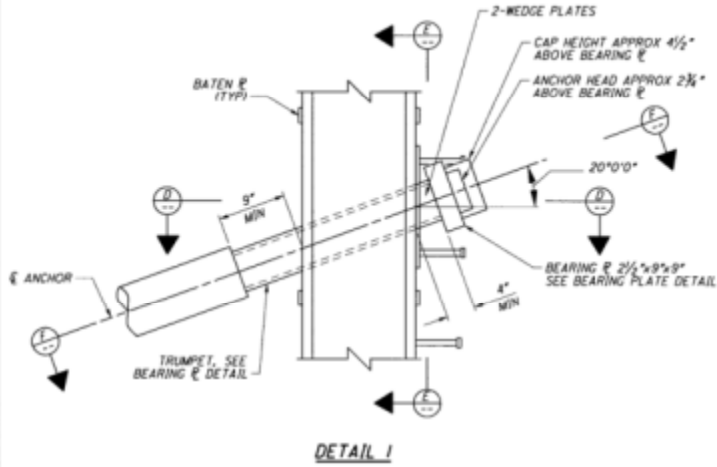

- NOTES:**
1. SEE SHEET 3 FOR GENERAL NOTES
 2. SEE SHEET 7 FOR ADDITIONAL NOTES.





























Other Completed
Remediation Work

TUS-416-13.0



TUS-416-13.0 After Repair



TUS-416-14.3



TUS-416-14.3



TUS-416-14.3 After Repair



TUS-416-14.3 After Repair



JEF-213-14.10

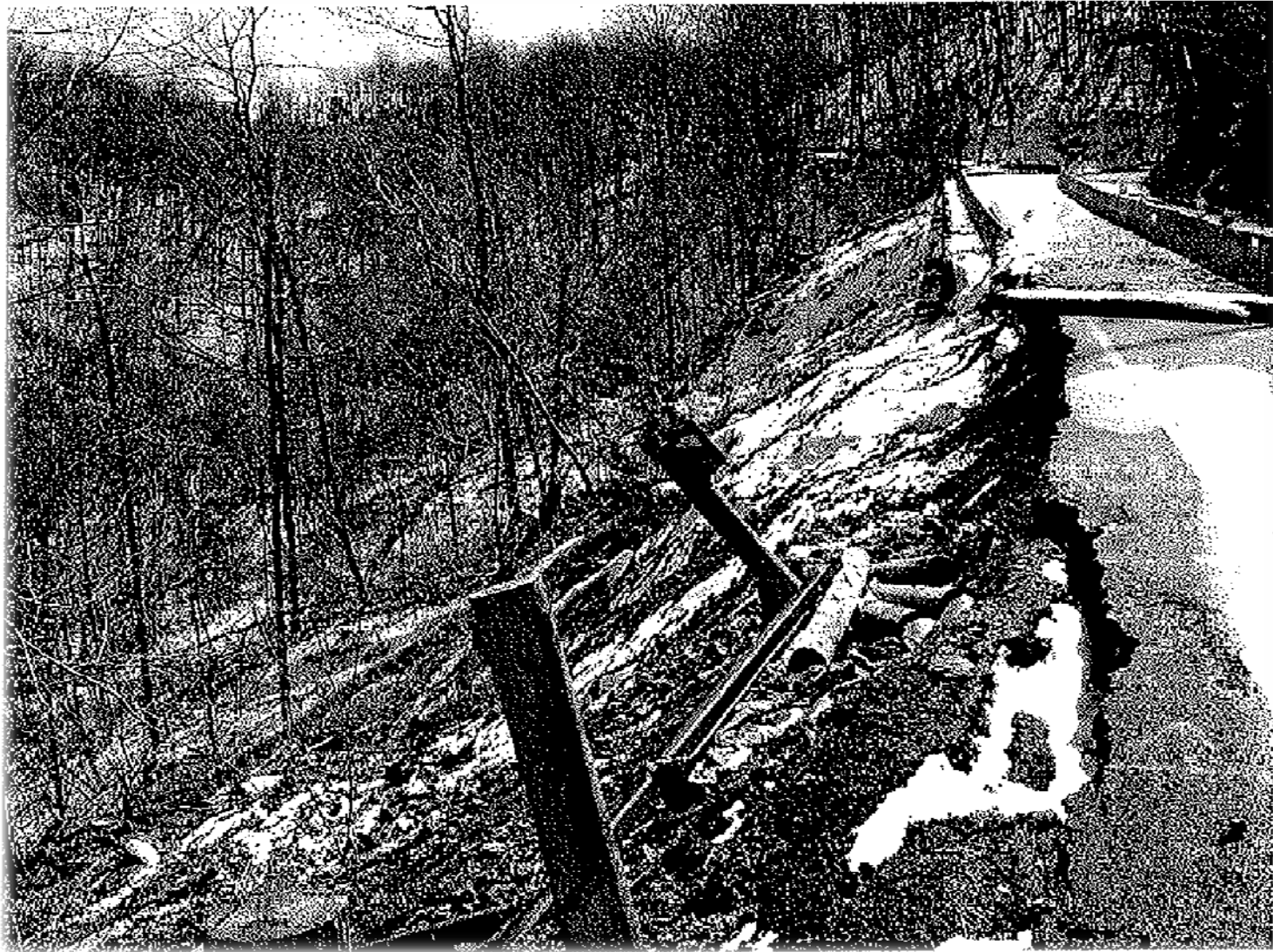

JEF-213-14.10 After Repair



TUS-212-6.7

TUS-212-6.7 After Repair



TUS-212-6.7 After Repair



Thank You
Questions?



A Special Request
for
I-70 Retaining Wall



"When Retaining Walls Fail: The Lessons Learned"

Steve Wendland, PE

Kleinfelder
Senior Principal Professional Engineer

Mr. Wendland has 25 years of experience in geotechnical engineering. He currently serves as a Senior Principal Professional Engineer in Kleinfelder's Kansas City, Kansas, office. His responsibilities include geotechnical engineering planning, analysis, and review and project management for a wide variety of projects throughout the United States. He also services as Kleinfelder's national Technical Practice Leader for Retaining Walls. In this role, Mr. Wendland coordinates engineering work, planning, risk reviews, and training of all civil, structural, and geotechnical engineers and construction professionals on projects with large retaining walls.

Mr. Wendland has completed geotechnical design and analyses for many aviation facilities, commercial buildings, power plants, industrial facilities, electric transmission lines, wastewater treatment plants, bridges, and marine structures. He has worked with the analysis of large dams, earth retaining structures, soil and rock anchors, reservoirs, solid waste landfills, and seismic analysis of foundations and earth structures. Mr. Wendland is experienced in supervision of field operations; he has been resident engineer for several foundation construction, earthwork, landfill and hydrogeologic investigation projects in varied geotechnical and geological environments. He has worked as the project manager for special inspections services for large commercial developments, government office buildings, wastewater and water treatment plants, aviation facilities, and highway and bridge projects.

Mr. Wendland has also conducted geotechnical forensic analyses of existing structures that have been impacted by expansive clay soils, compressible foundation bearing materials, and poorly constructed foundations. These forensic analyses have included a variety of failed retaining walls.

Prior to joining Kleinfelder, Mr. Wendland worked for an international engineering firm where he was the Geotechnical Supervisor. During this time, he oversaw all aspects of their Power Division Geotechnical Section, which consisted of a multi-cultural staff that handled all geotechnical aspects of more than \$1.1 billion worth of power projects per year.

Education

MS, Civil Engineering (Geotechnical), University of Texas - Austin

BS, Geological Engineering, Missouri University of Science & Technology

Registrations

Professional Engineer (P.E.) – Kansas, Missouri, Wyoming, Oklahoma

Registered Geologist (R.G.) – Kansas, Missouri

When Retaining Walls Fail: The Lessons Learned

Steve Wendland, PE, RG

Kleinfelder – Kansas City

National Technical Practice Leader for Retaining Walls

swendland@kleinfelder.com



Nebraska Section



February 17, 2012

ASCE's Mission

“Provide essential value to our members and partners, advance civil engineering, and serve the public good.”



We Will Experience Failures

For practicing civil engineers, a design will someday fail. You don't have a choice; it will happen. Even if it isn't your fault, it will cause you stress, embarrassment, legal harassment, anger, loss of money, or maybe the loss of your job.



Failures on My Projects

For me, the failures have been related to retaining walls. Everything else has been fine. Perhaps I am cursed.

Let's learn from some of these failures.



Why So Many Failing Retaining Walls?

- Water, water, water....
- Interaction between lots of people makes communication difficult
- Other causes < 10% of the time



Are MSE Walls More Problematic?

MSE = Mechanically Stabilized Earth



- They are more complex to design, construct, and inspect.
- They are more likely to be designed and built on a low-bid basis by a third-tier contractor.
- There are more firms involved = more complex communication.
- There are well established design standards (AASHTO, NCMA).

Case Histories Presented Here

- They are sanitized to protect others. I was at fault at least partially in many of them while working with my current or previous employers.
- “Fault” or “blame” is never black and white
- Other people involved probably disagree with my opinions, analysis, and memories.
- Some are obvious blunders. Some are more complex. Some may not even be a “failure”.
- I have many more case histories, but not enough time today...

What is “Failure”?

- My definition: When a retaining wall does not perform as expected.
- Not just when a wall collapses
- Who’s expectations?
- What if your expectations are different than your client’s?



Complex Communication

Who is Involved?

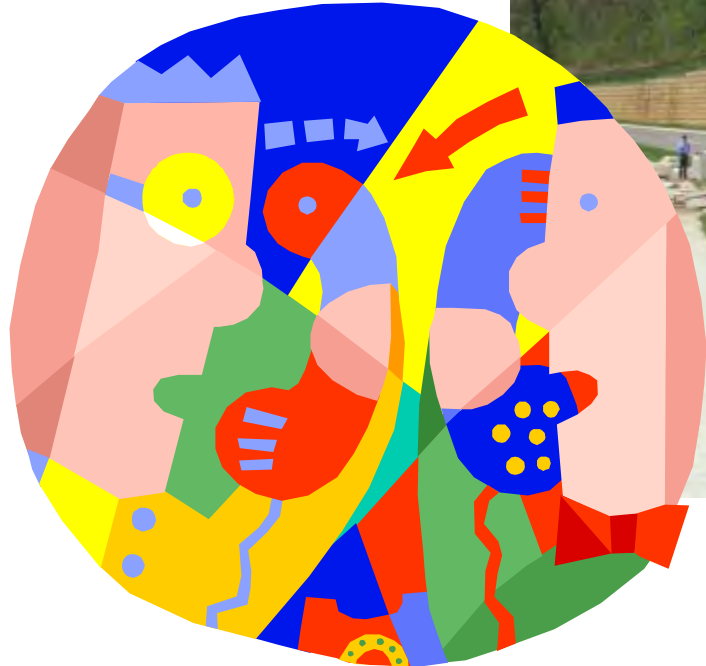

Communication among 9 to 14 Firms / Organizations

- **Civil Engineer** decides wall is needed
- **Geotechnical Engineer** determines geotechnical parameters for design and checks global stability
- **Structural Engineer** or a **Wall Design Engineer** completes design
- **Owner** and/or **Architect** will have input wall appearance and budget
- **Wall Supplier** will provide MSE wall materials or rebar and concrete
- **Surveyor** figures out where to build it
- **Landscape Architect** may control ground surface near it
- **General Contractor** will hire an **Earthwork Contractor** who may hire a **Specialty Contractor** to construct it
- **Ground Improvement Contractor** may densify foundation soils
- **Inspector** and/or **Construction Manager** monitors the construction

#1: High School Football Stadium

A Simple Cut and Fill

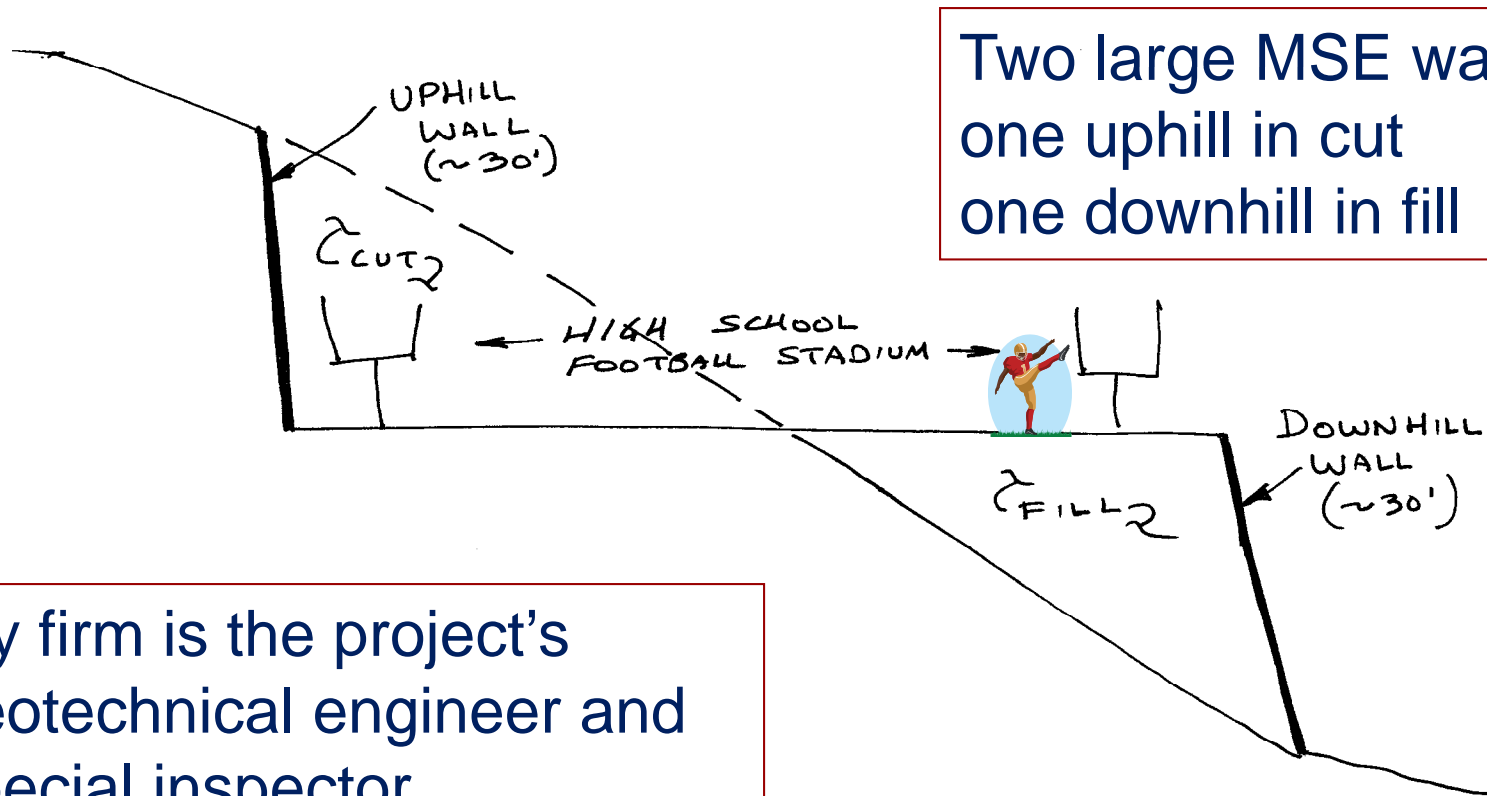

Site and Subsurface Conditions

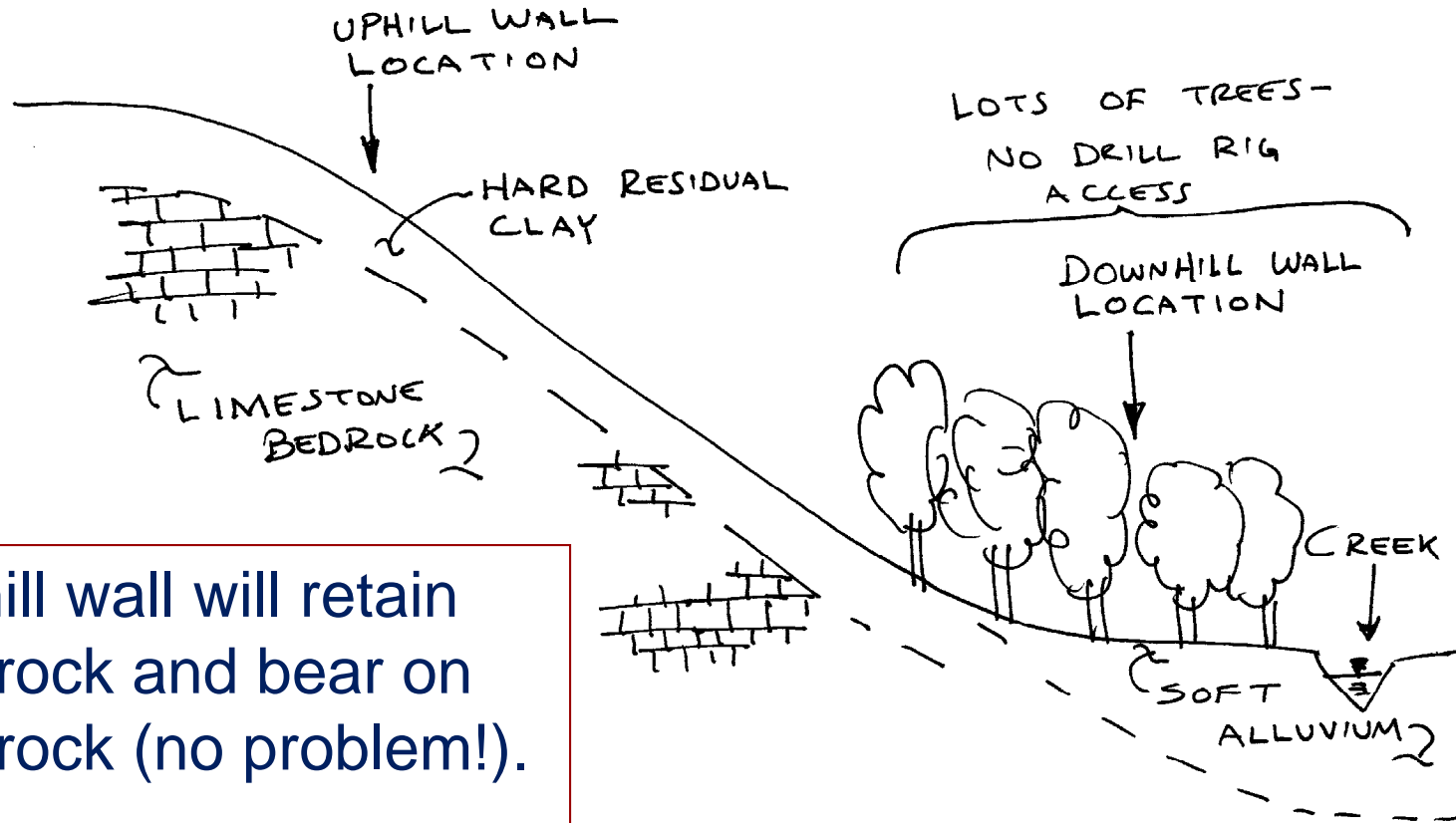

Uphill wall will retain bedrock and bear on bedrock (no problem!).

Downhill wall = ???

Downhill Wall 90% Built

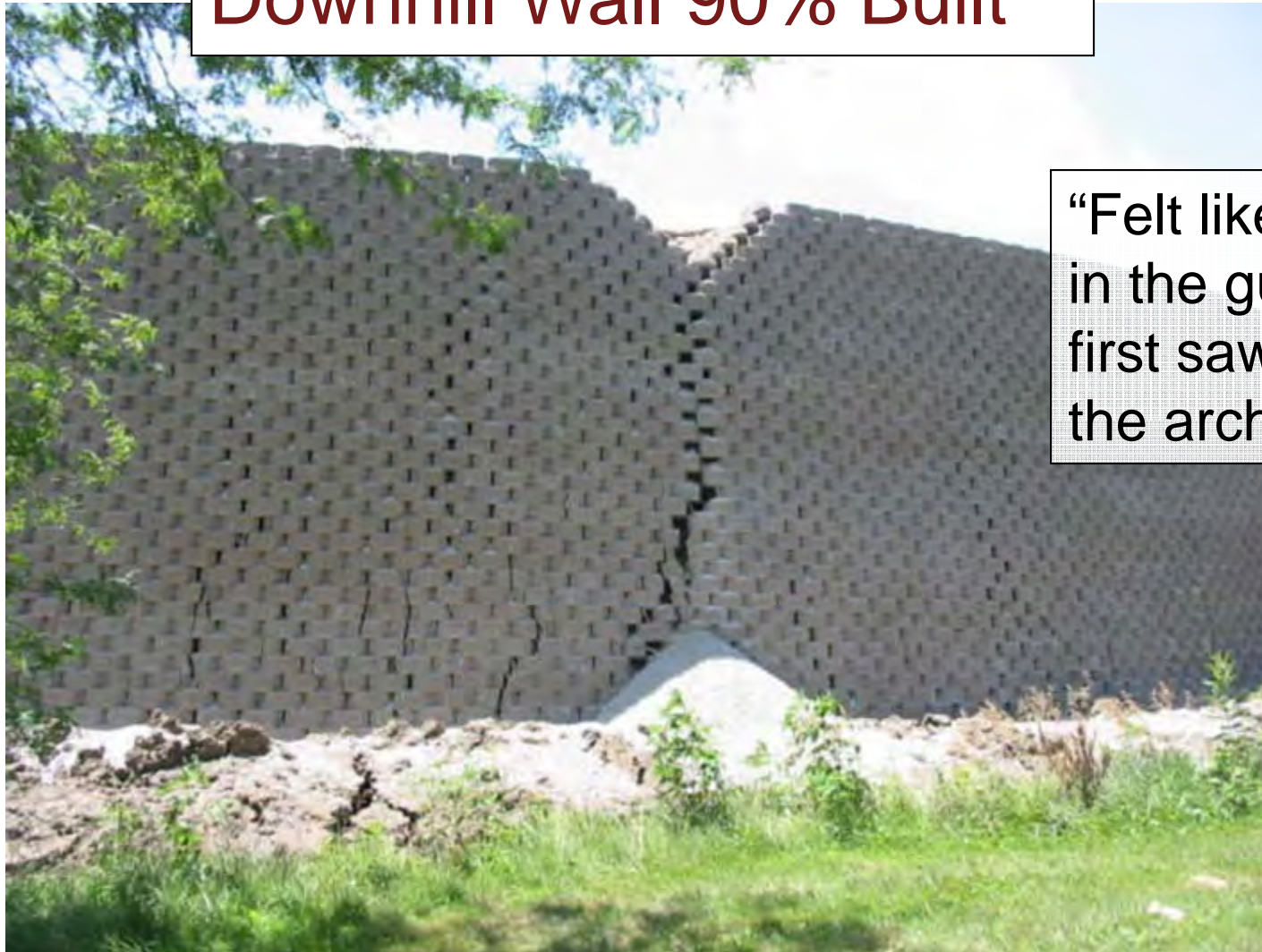

“Felt like a punch in the gut when I first saw it” says the architect



Tension cracks
behind top of wall
Don't fall in!



Bulging ground at toe of wall

Communication Failures

The wall experienced a **global stability failure**.

- Wall design engineer blundered. He used the recommendations for the uphill wall (on bedrock) to design the downhill wall (on soft soils).
- Architect did not distribute shop drawings and design calculations. Why didn't we ask for them? So, no one discovered the design errors until after the failure.
- Our field staff did not speak with our design geotechnical engineers. How did we inspect the downhill wall subgrade if we didn't have drawings?
- We did not ensure that the global stability analysis was completed prior to construction.

Miraculously, there was no litigation.

Lessons Learned

These should be common sense or standard practice:

- Always have the project's geotechnical engineer **review the wall design.**
- Inspector should **confirm** that the geotechnical review was completed.
- Geotechnical engineer should complete a **global stability analysis** or make sure it was completed by the wall design engineer
- Put **everything in writing.** “If it isn't written, it didn't happen”.

#2 - Apartment Complex

If at first you don't succeed, fail, fail again.

4 tiered, 32' tall, stacked block gravity retaining wall (a.k.a. "rockery") separating two apartment buildings

Here's what it looks like now, after it is fixed.

My firm was geotechnical engineer and special inspector.



Initial Design

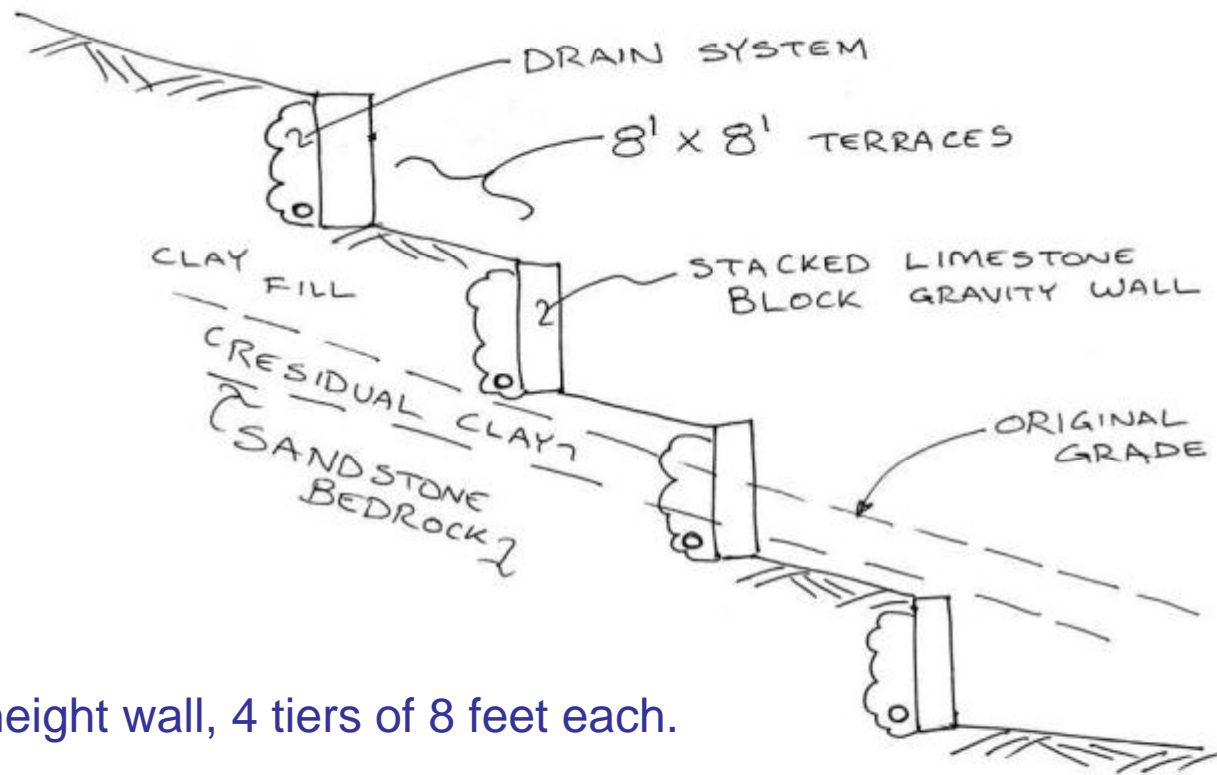

32 feet total height wall, 4 tiers of 8 feet each.

Overall slope would be 1H:1V. Lower 12 feet would be cut into sandstone bedrock.

We warned (in writing) of the risk of toppling of the walls and shallow slope failures in the upper soil-retaining portion. Such shallow failures could be repaired without endangering the buildings.

The First Time it Failed...

- No photos available.
- Only the lower tier had been built. Its construction had not been inspected.
- The contractor told us about the failure only after he fixed it.
- We sent out a letter with a strong caution about uninspected work.
- We should have walked away.

The second time it failed... during a heavy rain

3rd tier topples over, knocking over 2nd tier.
Lots of erosion behind and between blocks.

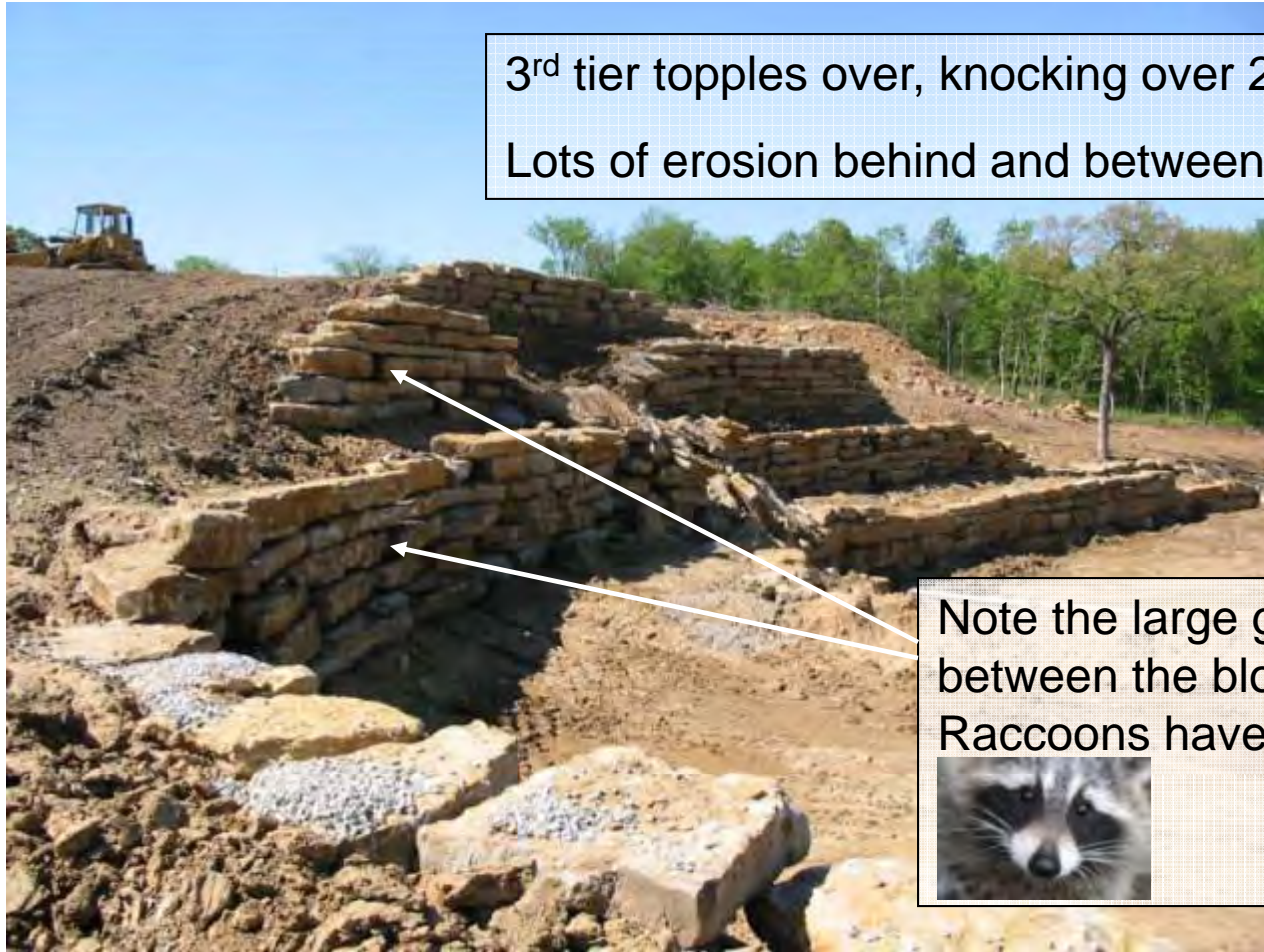

Note the large gaps
between the blocks.
Raccoons have moved in.



Wall design is significantly changed and it is rebuilt.

The third time it failed...

about 8 months later, again, during a heavy rain

Upper tiers slide
down the hill

Lower building is
partially crushed

Owner sues civil
engineer, who in turn
sues the geotechnical
engineer (us) and the
contractor



Communications Failures

The wall failed due to erosion between blocks and shallow slope failures.

- Despite advance written warning of toppling and shallow failures, owner failed to understand that risk.
- Letters (six of them!) warning of poor wall construction failed to concern owner.
- The last letter we wrote for the project failed to mention the wall's problems; so the owner thought they were solved.
- There were no specifications for the rockery. Contractor said he was "just doing what he was told". He was just making big piles of big rocks.
- After 2nd failure, there was a meeting at the site. I was too cantankerous and was asked to leave. When contractor proposed design changes, the civil engineer's representative (an inexperienced E.I.T.) said "Sounds good to me."

Lessons Learned

- Walk away from rotten projects. It is not our responsibility to rescue everything.



- Our last letter on the project did not remind the owner of the problem.
- Civil engineer had inexperienced staff (an EIT) accept design changes in the field without proper review.

#3 - High Rise Office Building

“Can you really build a wall there?”

The slope is naturally at 1.2H:1.0V and approximately 150 feet tall.

During heavy rains, it has frequent shallow slope failures.

It is covered with dense vegetation.

The developer wants to put a high-rise office building on the slope with the edge of the building 150 feet over the edge.

So, we'll need a big retaining wall on the slope to hold up the building pad.



The Constructed Wall



Immediate Concern – Global Stability

Global stability on steep, unstable hill is a major concern. The earthwork and wall construction contractors are nervous about the site. Bearing on massive limestone bedrock at the toe of the wall takes care of this concern. Also, 9 large drilled shafts with grade beams, permanent casing, and structural floor slab are within the wall backfill helping support the wall.





And Yet, the Wall Fails

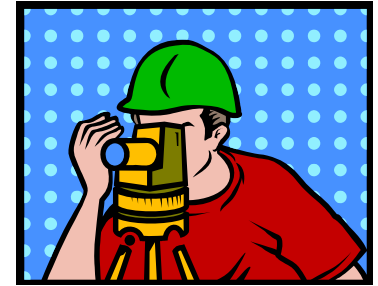

- The wall was built in the wrong location! It was off about 5 feet horizontally and 2 feet vertically.
- The construction surveyor misinterpreted a line on the drawings.
- Is this really a failure? If the owner thinks it is, then it is. They had to change the design of the patio around the edge of the building.

The Undersized Patio



Communication Failures

- There were 4 civil engineering / surveying firms working on the project. “A” did the grading plan. “B” designed the wall. “C” did construction surveying for the retaining wall contractor. “D” did construction surveying for the general contractor.
- They had different interpretations of the narrow, solid line on the grading plan that represented the wall’s location. Top of wall? Toe of wall?
- Topographic lines on grading plan were not accurate, no surprise on steep slope with dense vegetation. Various drawings have multiple disclaimers regarding who is responsible for accuracy of topography.

What does this line represent?
Top of wall?
Bottom of wall?
Wall at ground surface?

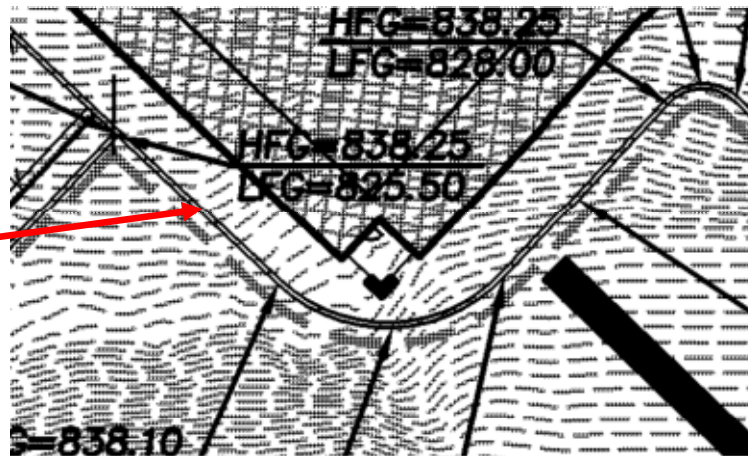

#4 - Big Box Retail Store

“Why did you ignore the manufacturer’s recommendations?”

16.5 ft tall, 800 ft long
with “big blocks”

My firm did the wall
design.

5-inch rain fall a few
weeks after completion
of construction.



24 inches of “clay” on top to limit infiltration of surface water.

Fill for reinforced zone behind the wall is “clean” sand

We used sand instead of clean gravel for drainage fill at contractor’s request to save \$\$\$



Why Did it Fail?

Heavy rain caused hydrostatic pressure which blew out the front face of the wall.

- We failed to take and distribute minutes of the conference call when the decision was made to use sand as the drainage fill. After the failure, some people had different memories of what we discussed.
- Manufacturer's written guidance on the use of sand fill immediately behind the wall was inconsistent.
- "Clay" cap was really silty loam, allowing water to soak in. Who gave the landscape architect authority to reject higher plasticity clays?

Lessons Learned

- Take the minutes for the project meetings and conference calls. If you write the history, you control the history.
- If the project deviates from the wall manufacturer's guidelines, get your client's and the contractor's acceptance in writing.
- Get to the job site as soon as you can after a failure so you see, hear, and participate in everything. If you're not there, they'll blame you!

How Much Water is Too Much?

- Can a typical wall drain system be overwhelmed?
- How much water can seep through the front face of an MSE wall?
- If there's a water line behind a wall, should the wall designer plan on it leaking?



#5 - Power Plant Water Line Excavation

A big ditch in south Florida

Typical sheet pile shoring with internal bracing. Contractors hate internal bracing – it gets in the way. “Can we please, please, please remove it for a few days? We’ll save **\$100,000** if we do.”

We are the design / build firm. We do our own geotechnical engineering. No one else to blame. The risk is all ours.

A few weeks later, the engineer who agreed to remove the braces asks, “Am I getting fired?”



What Went Wrong?

Lots and lots of rain.

Surface runoff was directed towards this area. Sheet piles dammed up the water behind the wall. Hydrostatic pressure builds up. Toe (passive resistance) loses strength due to upward seepage gradient

Walls move inward about 18", but don't collapse

Now the pipes and pumps don't fit in the excavation

It cost \$250,000 to fix it.



But what about the communication?

The Communications Succeeded, Even Though the Wall Failed

- Construction people knew the risk.
- Geotechnical engineer documented decisions and discussions in writing.
- Chief Engineer understood the decision, understood the impact of unexpected rain, and encouraged everyone involved to learn from the mistakes (“Next time, check the weather forecast and put some weep holes in the sheet piles!”).
- Geotechnical engineer was given positive encouragement by the Chief Engineer. Over the long term, such initiatives will be successful and profitable as long as safety is not sacrificed.

Lessons Learned

- Communicate the risk.
- Make sure everyone understands the risk.
- Put it in writing.
- Have good technical analyses to back up your judgment.
- Have a good boss.
- This type of risk taking works best on design / build or projects.

#6: Three Year Old Wall Starts Moving

“How long have those cracks been there?”

Completely stable for 3 years. Starts sliding horizontally at about 1 inch per month, cracks are visible. No apparent groundwater issues

Can't figure out cause

Fixed with rock anchors, and without attorneys, before it collapsed.

Consider an “as built” laser survey of any complex wall.



Summary – Water Control

- “90% of soils problems are really water problems.”
- In a failure, assume water is guilty until proven innocent.
- Where is the water coming from? How much will there be? Mother Nature will surprise you.
- How is it going to drain? Where is it going to go?
- How will the foundation be impacted by water?
- Are there any water lines, sewers, or detention basins nearby? What if they leak? Will they be damaged by typical settlement of the wall?
- How will that change day to day and over the years?

Summary - Communications



- Communicate with everyone involved during design and construction. Be proactive; don't wait for others to do it.
- Document it all in writing.
- Take prudent risks only if the project team understands and accepts it
- Communicate regularly with field technicians.

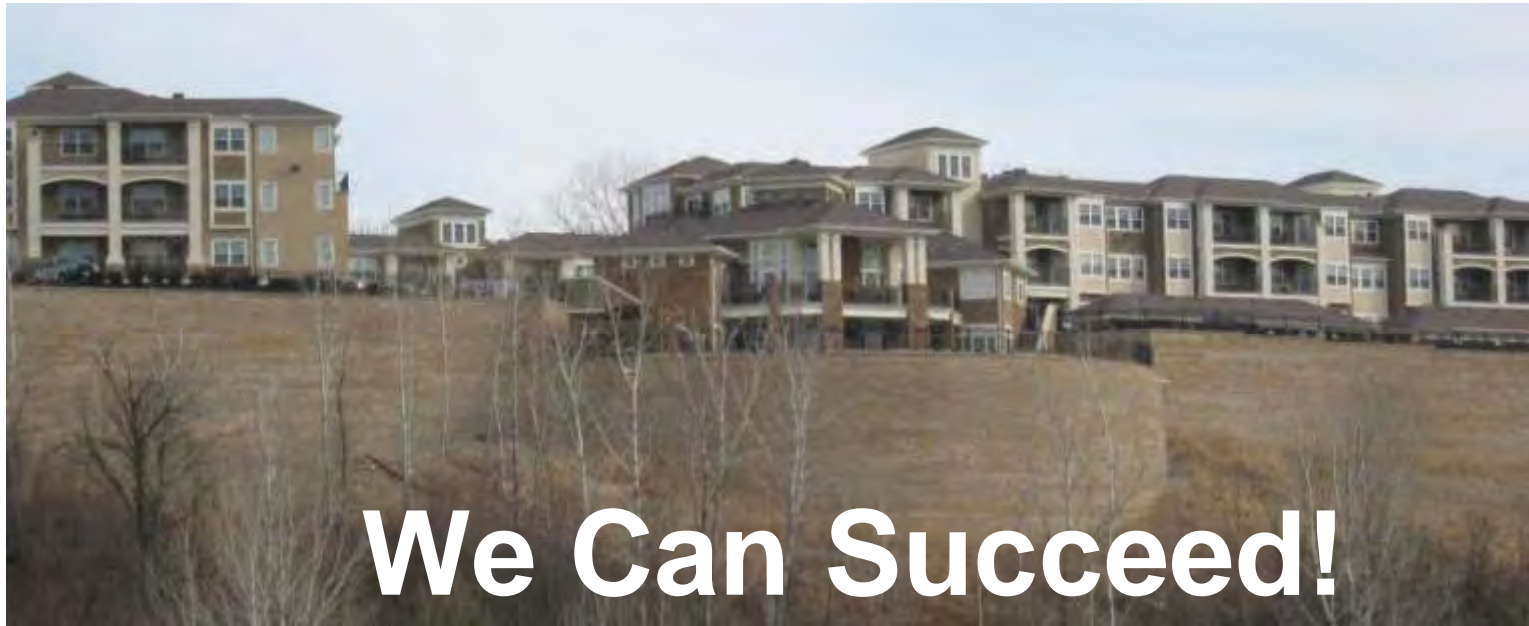

Any Questions?

swendland@kleinfelder.com

Thank you Nebraska ASCE

“Design Challenges of I-80 Soil Nail Wall”

Lok Sharma, PE

Terracon Consultants

Mr. Sharma has over 40 years of experience in investigation, analysis, design, construction and project management of a variety of projects relating to mining, tar sands development, industrial plants, water resource developments and transportation facilities.

His experience with transportation projects extends from roadway projects to airstrips and runways. Mr. Sharma has guided geotechnical efforts on many bridge construction projects. His involvement has included site investigations and design of bridge foundations, reinforced earth bridge abutments and fills, transit tunnels, large dams and spillway structures, soil nail walls, excavation supports, slope stability, grouting and geotechnical instrumentation.

Lok obtained his Master's degree from University of Albert, Canada and is a registered professional engineer in Kansas.

Ed Prost, PE

Terracon Consultants

Mr. Prost is a Principal of Terracon and the manager of geotechnical engineering at Terracon's Omaha, Nebraska office where he supervises the geotechnical engineering operations. Mr. Prost has 30 years of experience primarily in the Midwest, and in Texas involving a wide variety of projects including major oil refineries, petrochemical plants, corn and soybean processing/storage facilities, ethanol production plants, major pipelines, sewer projects, railway bridges and spurs, wind farms, high rise office towers with up to 50-foot-deep basement excavations, major bridge and highway projects for the Nebraska Department of Roads, Iowa DOT, and TXDOT, floodway improvements, dams and levees, soil retaining structures, large commercial and retail developments as well as residential subdivisions. He was the lead geotechnical engineer for recent new energy units at both the MidAmerican Energy Walter Scott Energy Center in Council Bluffs, and the Nebraska City Power Station for OPPD.

Mr. Prost has done considerable work in computer-aided analysis on geotechnical engineering and instrumentation projects, including settlement evaluation, slope stability and soil-structure interaction. He was the designated instrumentation engineer, responsible for the installation of vibrating wire strain gauges and inclinometers on a major bulkhead installation for the U.S. Navy Homeport in Corpus Christi, Texas. Mr. Prost has also directed the instrumentation installation and interpretation for several Nebraska Department of Roads bridge and embankment projects.

Ed completed his Bachelors Degree and Masters level studies at the University of Missouri-Rolla now known as the Missouri University of Science and Technology. Ed is a registered professional engineer in Texas, Nebraska, Iowa, South Dakota, and Minnesota.



***Design Challenges of I-80 Soil
Nail Wall, Omaha NE***

By

Lok M. Sharma, P.E.

and

Edward D. Prost, Jr., P.E.

Terracon

NeDOR

Project Overview

24th Street to Missouri River



**I-480/I-80/US-75
Interchange**

Rosenblatt Stadium

Henry Doorly Zoo

Kenefick Park

**Missouri River
Bridges**

Courtesy of NeDOR

Retaining Wall Locations

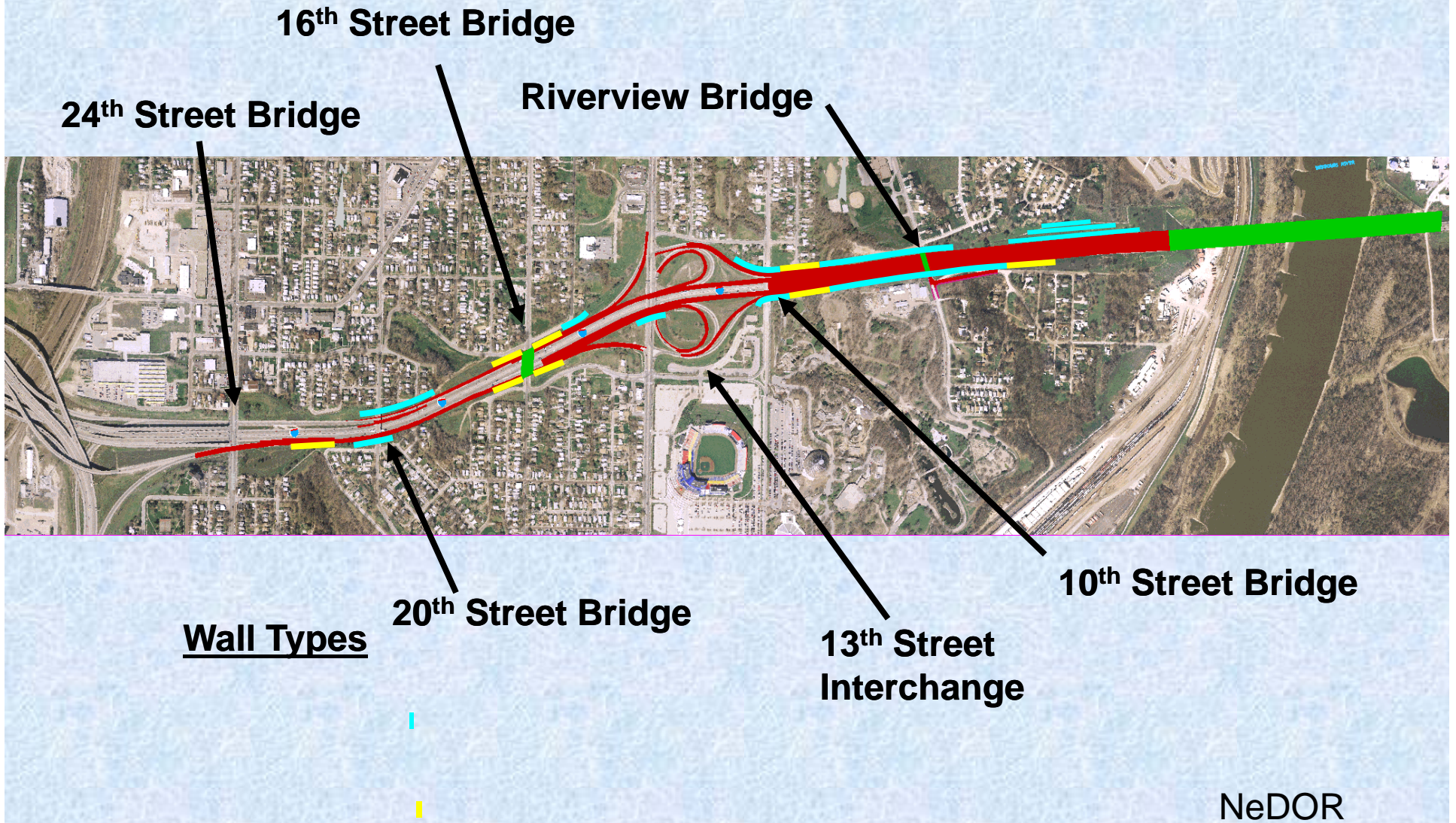



Picture credit: Brian Johnson. NDOR

Three Tiered Wall Location



NeDOR

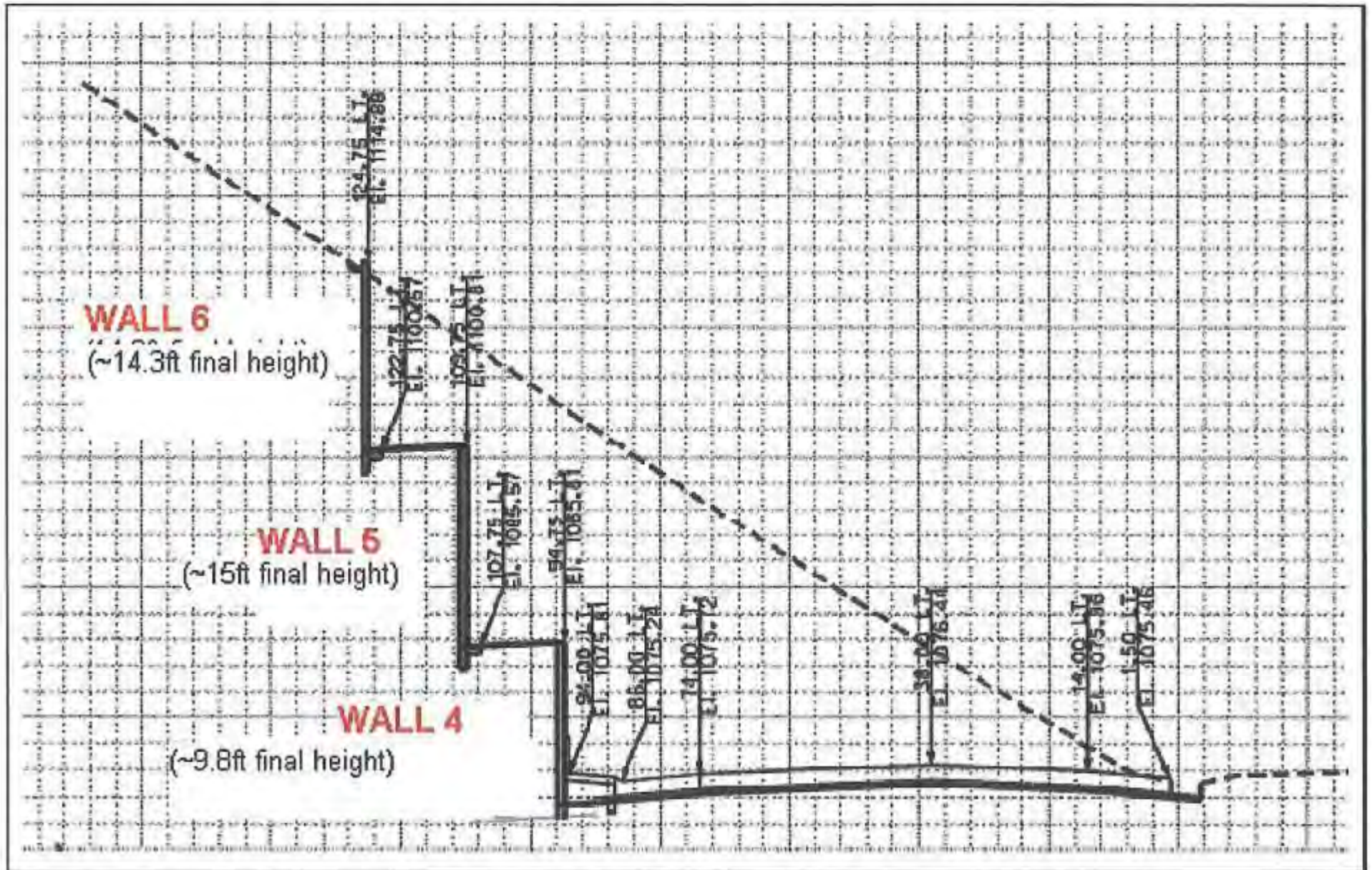

Figure 2.1 Cross Section of Three Tier Soil Nail Wall at Station 1424+00

Table 1: Soil Profile

	Borings				Remarks
	MR1	MR2	MS1	MS2	
Location	1424+00, 146 LT	1417+50, 100LT	1423+40, 20 LT	1418+80, 25LT	Highest top and lowest bottom elevations of the walls-
Surface Elevation	1120.5	1118.0	1076.0	1082.0	
Boring Depth	41	30.1	36	30.7	
Bottom of Boring Elev.	1079.5	1087.9	1040.0	1051.3	
Soil Encountered					
	El 1120.5-1079.5 Lean CLAY (CL) trace sand, very stiff (Peoria)	El 1118.0-1087.9 Lean CLAY (CL) trace sand, very stiff (Peoria)	El 1076.0-1054.5 Lean CLAY (CL) trace sand, very stiff, (Peoria)	El 1082.0 - 1066.0 Lean CLAY (CL) trace sand, very stiff, (Peoria)	Wall-4: 1095.92 - 1065.87
			EL 1054.4-1045.5 Fat CLAY (CH) very stiff (Alluvium)	El 1066.0 - 1056.0 Lean CLAY (CL) trace sand, stiff (Loveland)	Wall-5: 1112.27 - 1078.29
			El. 1045.5-1040 Poorly graded SAND (SP) (Alluvium)	El 1056-1051.3 Lean CLAY, stiff (Alluvium)	Wall-6: 1117.45 - 1095.89

Water level was not reported in any of these four borings. Except at CPT ms1 located at elevation 1076 feet at Station 1423+50, pore water pressure was not measured at other two CPTs ms1 and MR1. Pore water pressure recorded below elevation 1072 feet at CPT ms1. For the soil nail wall design, water table is considered at elevation 1070 feet.

1.2.2 Geotechnical Design Parameters

Based on the supplied data and the logs, the following design profile and soil parameters are considered in the design of Soil Nail Walls 4, 5 and 6:

Soil Type: Lean Clay

Design Water Table: Elevation 1070 feet (perched WT)

Ultimate Cohesion: 150 psf

Ultimate Friction Angle = 27 degree

Moist Unit Weight = 120 pcf

Ultimate Soil Nail Grout/Soil Bond Strength = 10 psi

1.3.1 STEEL NAIL AND REINFORCEMENTS

The design uses following data for soil nails, reinforcing bars, steel plates and studs:

Soil Nails = 75 ksi grade. epoxy coated threaded bars steel

Steel Plates and Studs = 36 ksi grade steel

Facing reinforcement bars and wire mesh = 60 ksi grade steel

1.3.2 SHOTCRETE AND REINFORCED CONCRETE

Concrete (CIP for Permanent Facing) = 4000 psi grade

Shotcrete (Temporary Facing) = 4000 psi grade

Grout (for soil nail wall) = 3000 psi grade

Bond Stiffness, K_{BOND}	5.4×10^7 psf
Bond Strength, S_{BOND}	3000 lb/ft
Grout/soil Bond Friction Angle	19 degree
Hole Diameter	8 inch
Hole Perimeter	2.10 ft

2.1.1.4 Wall Facing Parameters

Thickness	1.00 ft {8-inch thick CIP + 4-inch shotcrete}
Young's Modulus	4.5×10^8 psf
Poisson's Ratio	0.25
Compressive yield strength	4000psi = 576,000 psf
Tensile yield strength	10% of compressive = 57,600 psf

Soil Type	Lean Clay
Design Water Table	Elevation 1070 feet (perched WT)
Moist Unit Weight	115 pcf above water table 120 pcf below water table
Young's Modulus	1×10^5 psf
Poisson's Ratio	0.35
Ultimate Friction Angle	27 degree
Ultimate Cohesion	150 psf
Ultimate Tension	75 psf (Tension cut-off used)
Ultimate Soil Nail Grout/Soil Bond Strength =	10 psi

2.1.1.3 Soil Nail Parameters

Nail diameter	1-in diameter
Nail lengths	Variable
Nail strength	75 ksi yield strength steel bars
Yield strength	yield force = 58,875 # in both compression and tension
Nail Young's modulus	4.18×10^9 psf (2.9×10^7 psi)

1.4. FACTOR OF SAFETY

Table 1.1 provides the minimum Factor of Safety (based on Page D9, Circular 7) used in this analysis

Table 1.1 Required Factor of Safety

Resisting Component	Symbol	Minimum Factor of Safety	
		Static Loads	Seismic Loads
Global Stability (Long-term condition)	FS_G	1.5	1.1
Global Stability (1st Excavation Lift)	FS_G	1.2	NA
Bearing Capacity	FS_H	3.0	2.3
Sliding Stability	FS_{SL}	1.5	1.1
Pullout Resistance	FS_P	2.0	1.5
Soil Nail Tensile Strength	FS_T	1.8	1.35
Facing Flexure	FS_{FF}	1.5	1.1
Facing Punching Shear Failure	FS_{FP}	1.5	1.1
Headed-Stud Tensile Failure	FS_{HT}	2.0	1.5

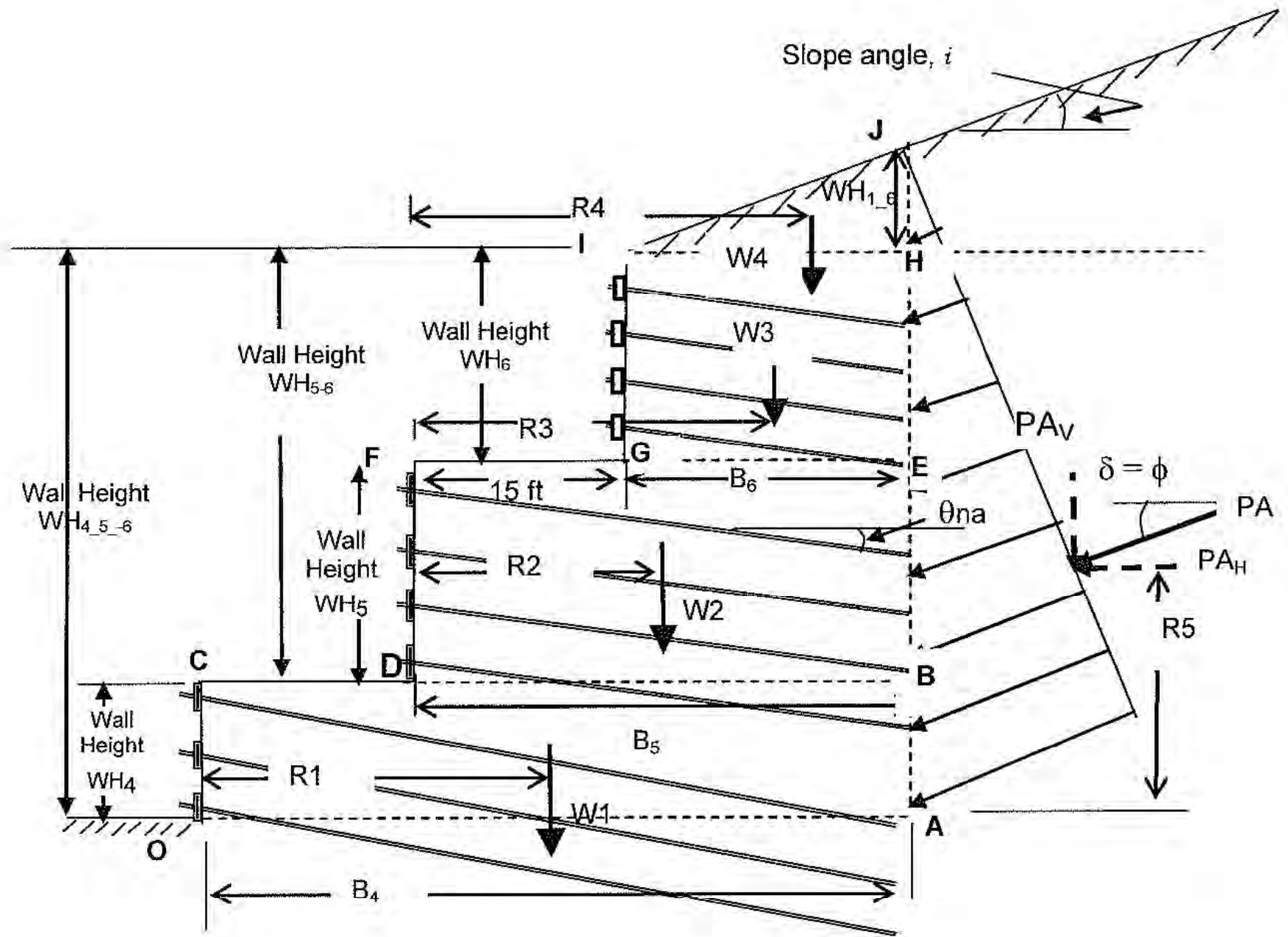

Figure 2.16. Soil Nail Wall Block - Static Analysis

Table 3.1.1: Factor of Safety for Facing Design and Required Capacities

Facing Capacity	Symbol	Static Loads		Seismic Loads	
		FS	Capacity (kips)	FS	Capacity (kips)
		Temporary Facing			
Flexure	R_{FF}	1.35	25.7	Not Applicable	
Punching Shear	R_{FP}	1.35	25.7		
Headed Stud Tension	R_{FS}	Not Applicable			
		Permanent Facing			
Flexure	R_{FF}	1.5	28.5	1.1	20.9
Punching Shear	R_{FP}	1.5	28.5	1.1	20.9
Headed Stud Tension	R_{FS}	2	38.0	1.5	28.5

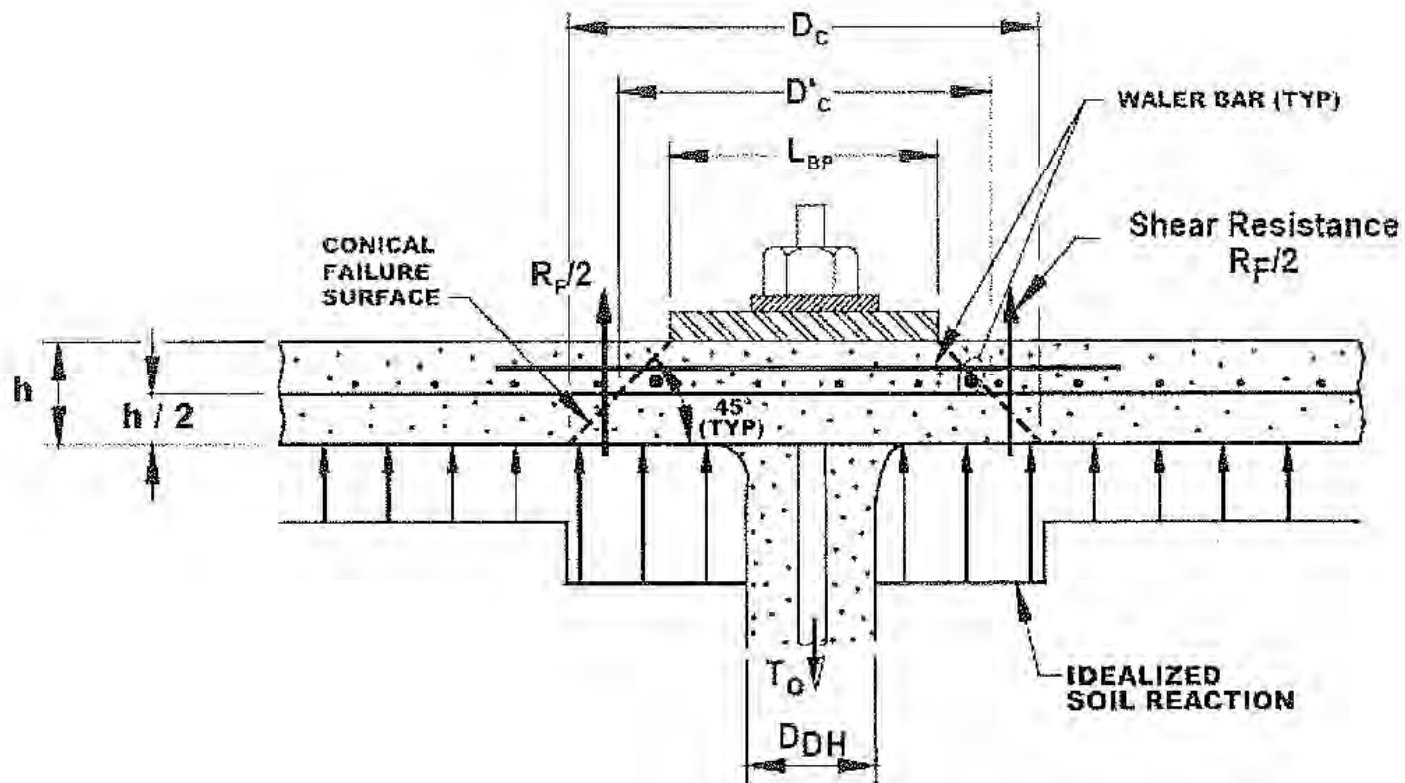
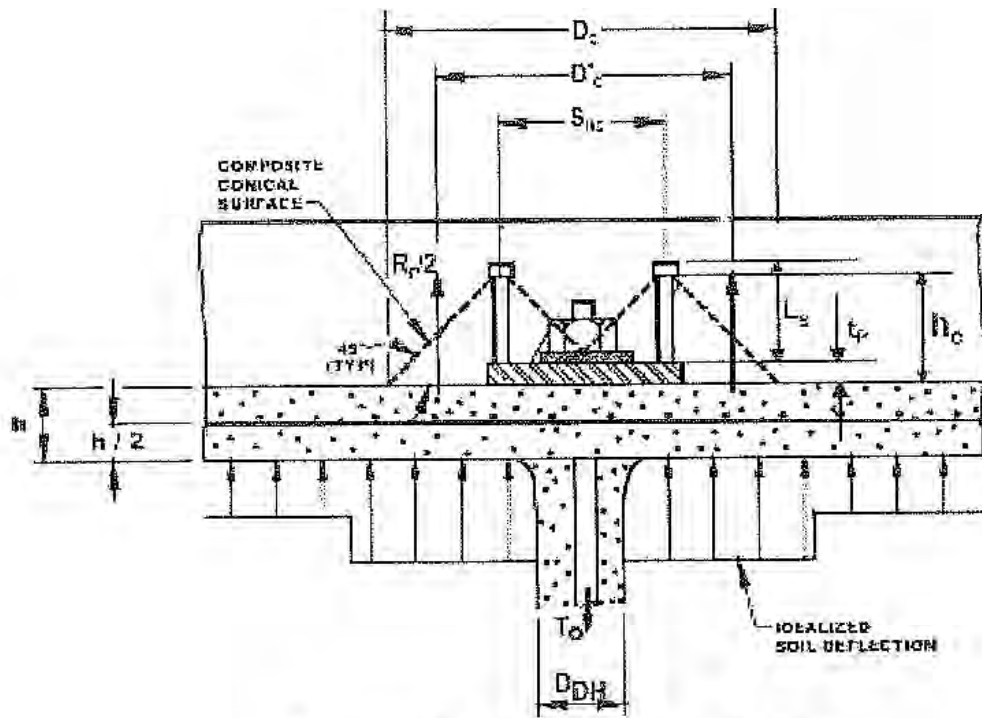
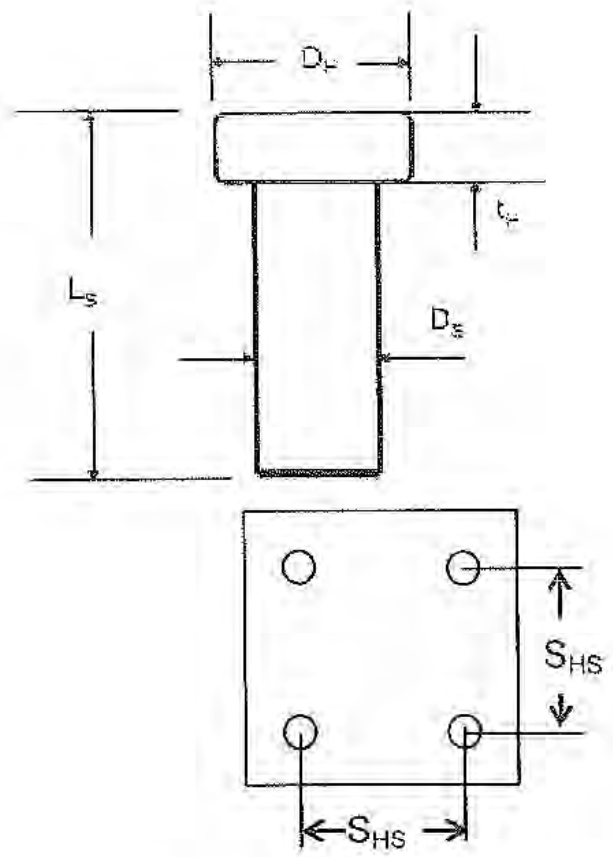

Figure 3. Shotcrete facing details
 (See Page 101 of FHWA Circular 7 for details)

Note: Because it is a permanent wall, though not show in this diagram, the plates will be studded.



(b) PERMANENT HEAD-STUBBED CONNECTION



Nail Head Details

Figure 4. CIP facing details

(See Page 101 of FHWA Circular 7 for details)

Note: There will be a 4-inch thick shotcrete facing behind the CIP facing.
The shotcrete facing is not shown in the diagram

Seismic load - an equivalent pseudo static load is considered. Based on the USGS National Seismic Hazards Map, Peak ground acceleration A1 for 10% probability of exceedence in 50 years is 0.01819g for Omaha, Nebraska.

Accounting for potential soil amplification through over 40 feet of soft clays, the normalized peak ground acceleration, (See Section 5.4.5.2, page 78 FHWA Circular 7)

$$A = S \cdot A_1 = 2.0 \cdot 0.01819g = 0.0364g$$

normalized acceleration coefficient for the wall center of gravity = A_m

$$= (1.45 - A) \cdot A = (1.45 - 0.0364g) \cdot 0.0364g = 0.05143g$$

$$\text{Design horizontal acceleration} = 0.67 \cdot A_m = 0.034g$$

$$\text{Design vertical acceleration} = 0 \text{ (See Page 4-23, FHWA SA-96-069R)}$$

Use Mononobe-Okabe Equation for to calculate seismic earthpressure coefficient K_{AE}

$$K_{AE} = \frac{(\cos(\phi_{\text{eff}} - \theta - \beta))^2}{(\cos(\theta))(\cos(\beta))^2(\cos(\delta_s + \beta + \theta))} \cdot \left[1 + \left[\sqrt{\frac{\sin((\phi_{\text{eff}} + \delta_s)) \cdot \sin(\phi_{\text{eff}} - \theta - i)}{\cos(i - \beta) \cdot \cos(\delta_s + \beta + \theta)}} \right] \right]^{-2}$$

Where, $\theta = \tan^{-1}(K_h/K_v)$, and K_{AE} = total (static + dynamic) active earth pressure coefficient

K_h and K_v are the design earthquake acceleration in horizontal and vertical directions, respectively.

K_h = half of peak earthquake ground motion at the project site.

$K_v = 0$ assumed, See Page 4-23 of the FHWA Manual

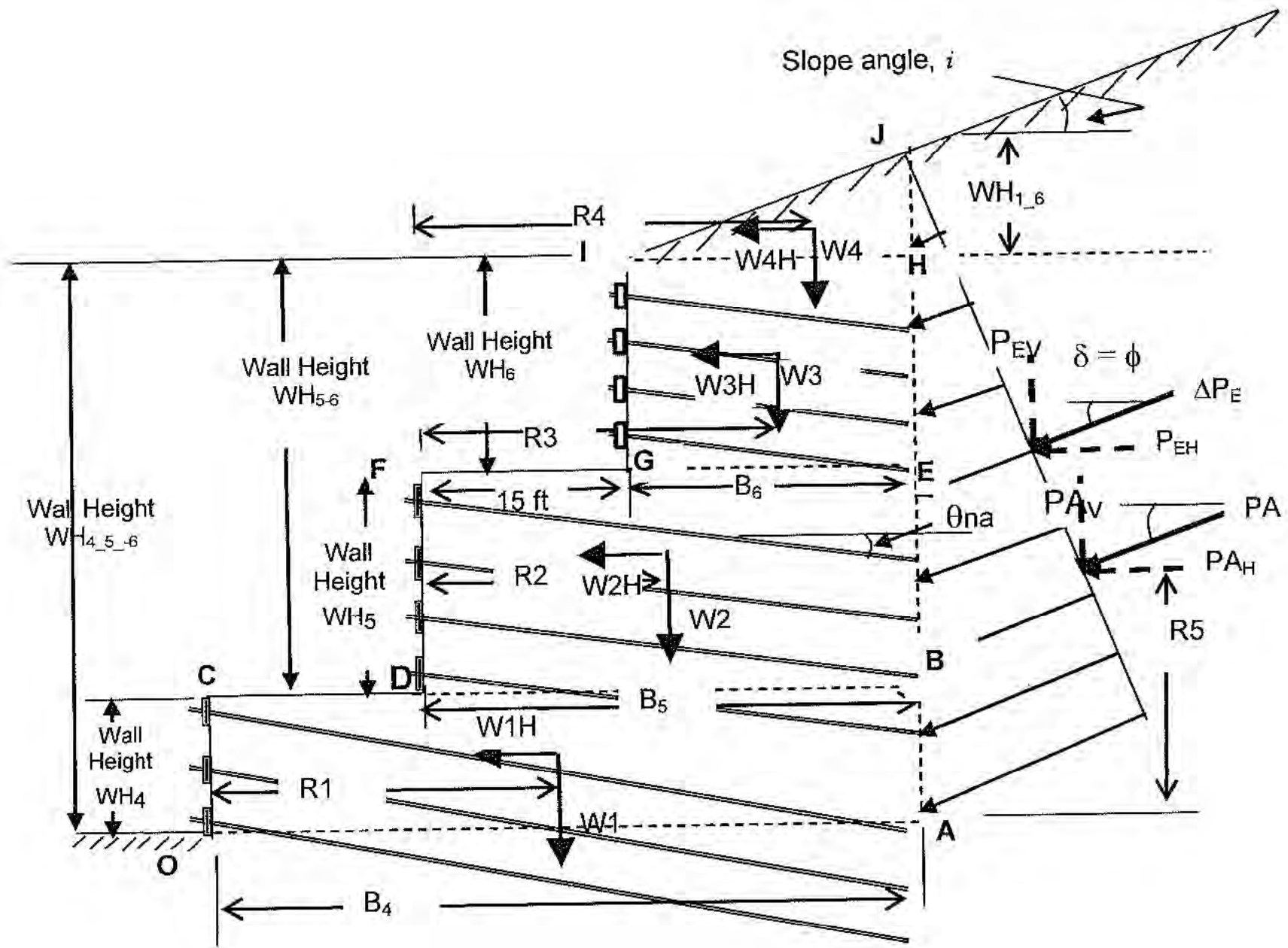

Figure 2.17 Soil Nail Wall Block - Static+Seismic Analysis

Date: 10-20-2009

SnailWin 3.10 File: Wall-4_-4rows-of-nails

Minimum Factor of Safety = 1.41

30.0 ft Behind Wall Crest

12.0 ft Below Wall Toe

H= 14.0 ft

LEGEND:

Pp= 32.6 k/ft

PS= 30.0 Kips

FY= 75.0 Ksi

Sh= 5.0 ft

Sv= 3.5 ft

GAM	PHI	COH	SIG
pcf	deg	psf	psi
1	120.0	27	150 10.0

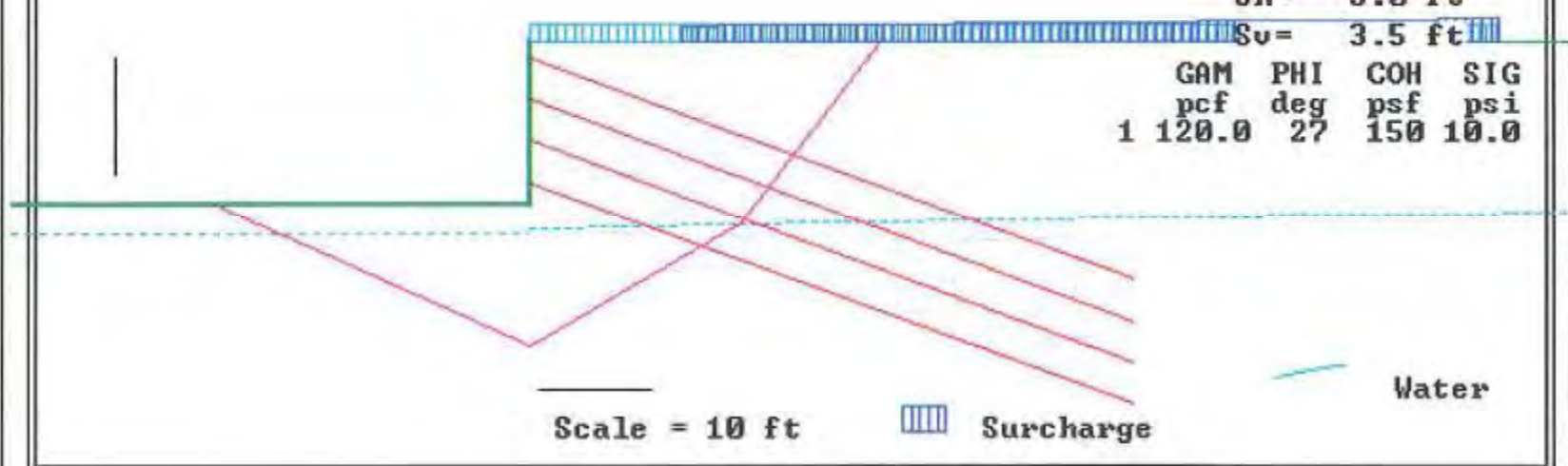

Scale = 10 ft

Surcharge

Water

JOB TITLE : Stability Analysis of the Existing Slope (FOS=1.85)

(*10^2)

FLAC (Version 6.00)

LEGEND

20-Aug-09 12:40

step 10422

-1.667E+01 <x< 3.167E+02

-8.167E+01 <y< 2.517E+02

Factor of Safety 1.85

Max. shear strain-rate

0.00E+00

1.00E-04

2.00E-04

3.00E-04

4.00E-04

5.00E-04

Contour interval= 1.00E-04

Extrap. by averaging

Grid plot

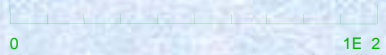

Velocity vectors

max vector = 1.720E-02

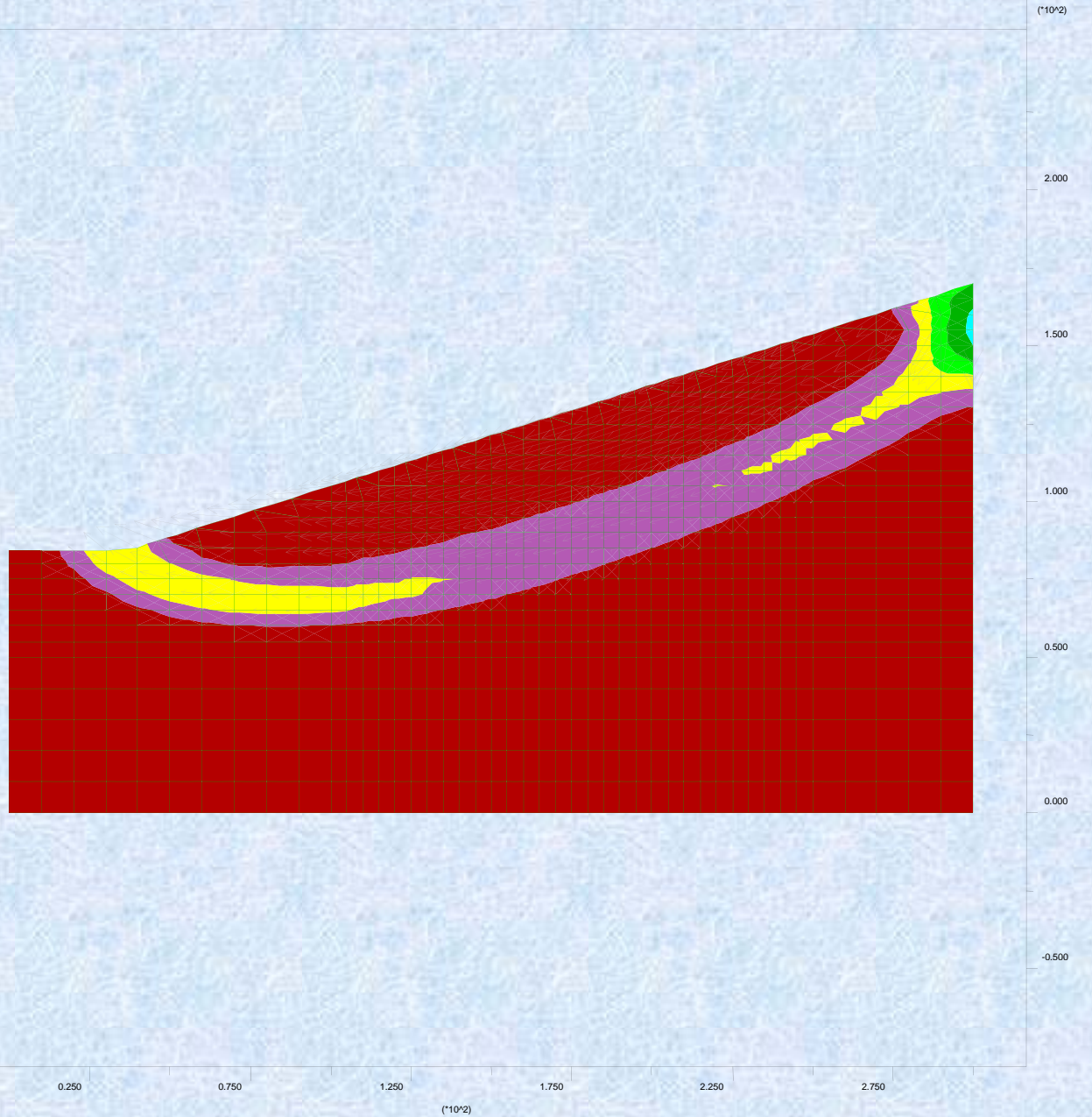
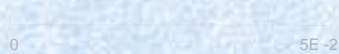

JOB TITLE : Wall (Top Tier) Stability (FOS 1.76)

(*10²)

FLAC (Version 6.00)

LEGEND

18-Aug-09 14:06

step 104992

-1.667E+01 <x< 3.167E+02

-8.167E+01 <y< 2.517E+02

Factor of Safety 1.76

Max. shear strain-rate



Contour interval= 1.00E-06

Extrap. by averaging

Grid plot

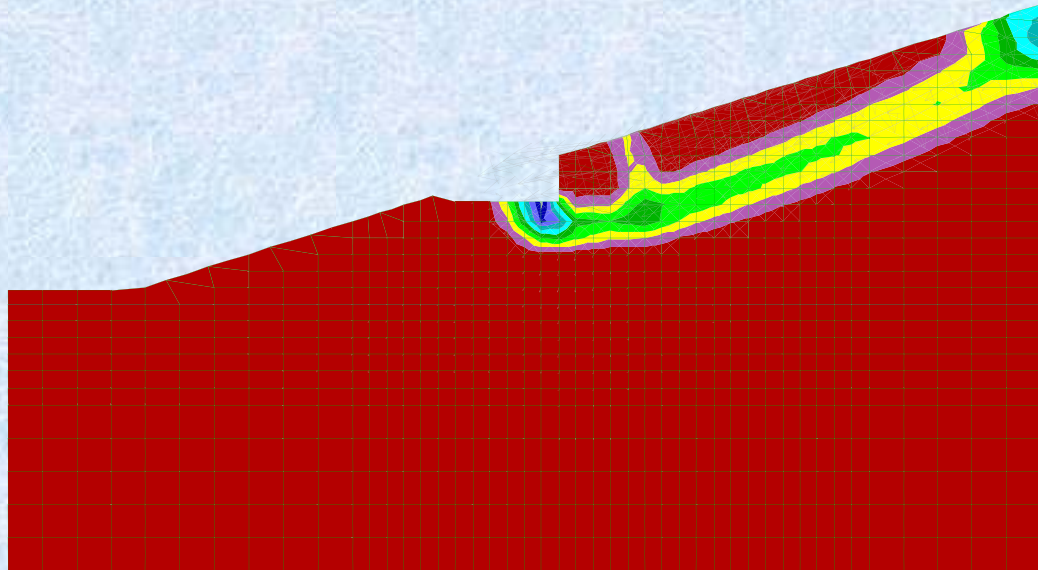
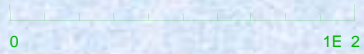

2.000

1.500

1.000

0.500

0.000

-0.500

0.250

0.750

1.250

1.750

2.250

2.750

(*10²)

JOB TITLE : Wall-5 and Wall-6 (Top and Middle Tiers) Stability (FOS 1.59)

(*10^2)

FLAC (Version 6.00)

LEGEND

18-Aug-09 16:05

step 107180

-1.667E+01 <x< 3.167E+02

-8.167E+01 <y< 2.517E+02

Factor of Safety 1.59

Max. shear strain-rate

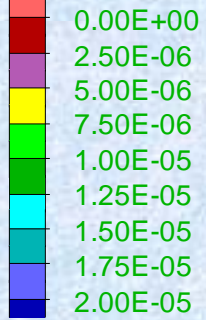

Contour interval= 2.50E-06

Extrap. by averaging

Grid plot



Cable plot

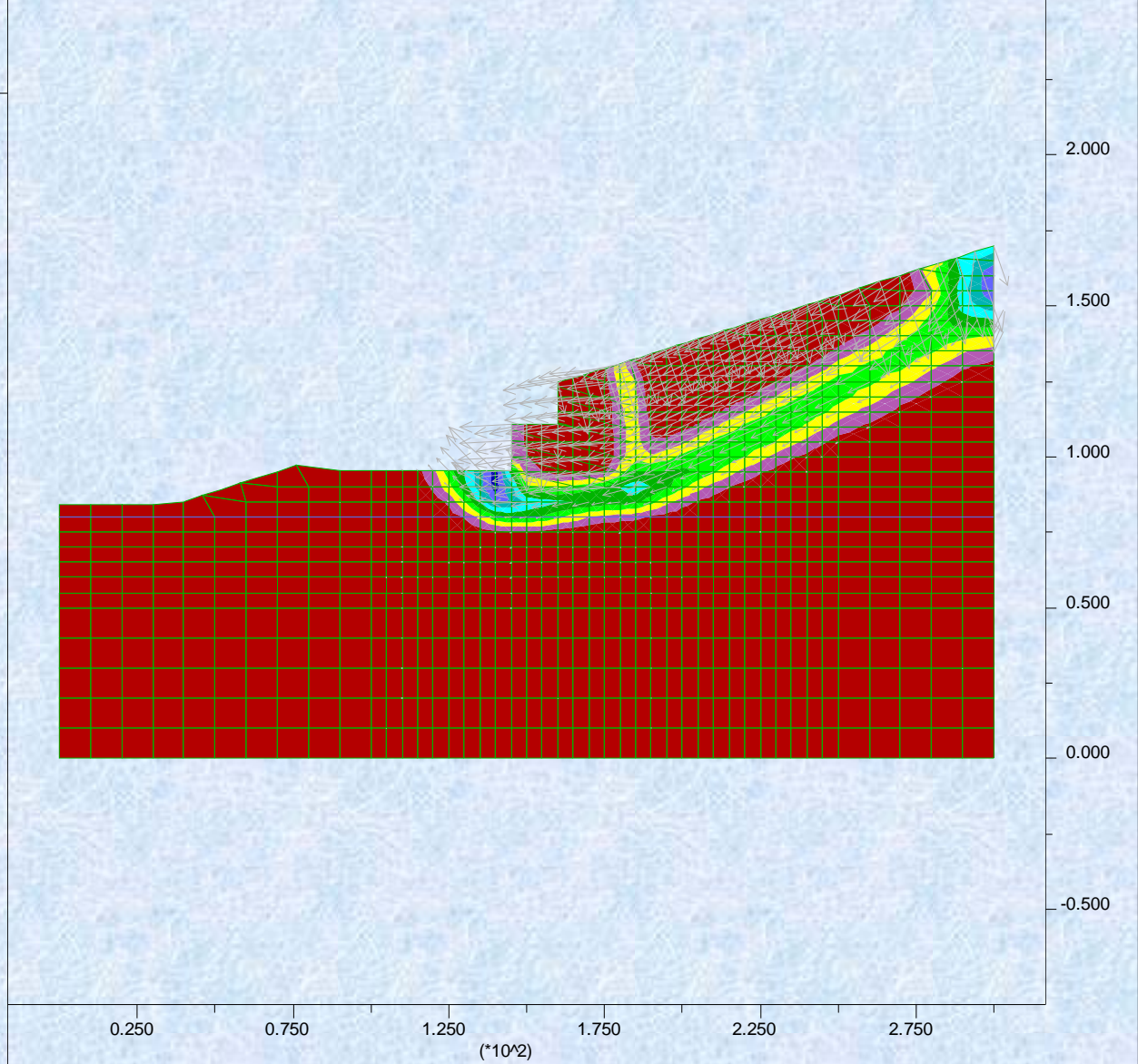

FLAC (Version 6.00)

LEGEND

18-Aug-09 17:36

step 285485

-1.667E+01 <x< 3.167E+02

-8.167E+01 <y< 2.517E+02

Factor of Safety 1.37

Max. shear strain-rate



Contour interval= 1.00E-06

Extrap. by averaging

Grid plot

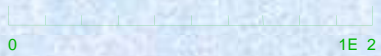

Cable plot

Water Table

Net Applied Forces

max vector = 5.141E+02

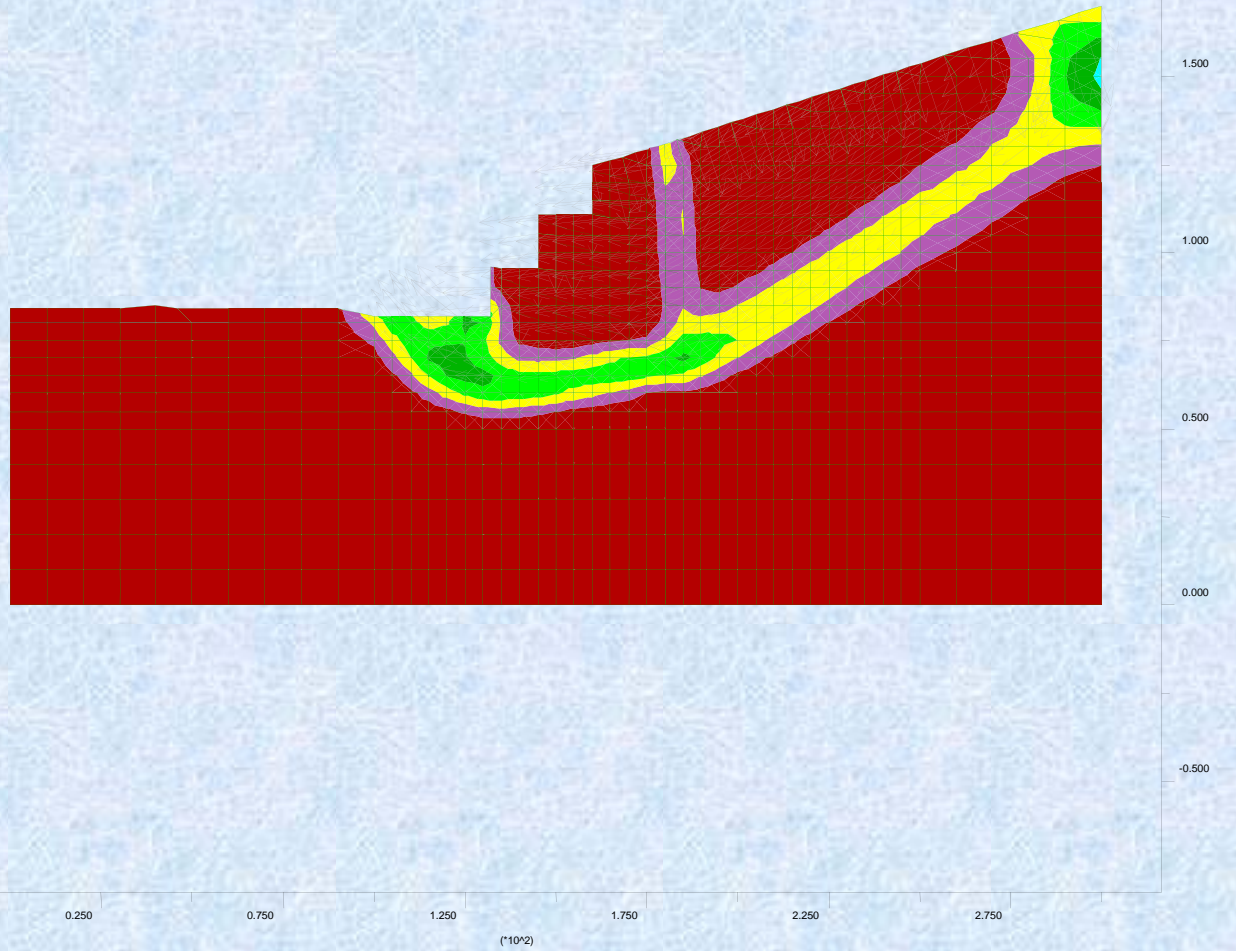

JOB TITLE : Wall-4, 5 and 6 (Top, Middle and Bottom Tiers) Long Term Stability (FOS 1.48)

(*10²)

FLAC (Version 6.00)

LEGEND

18-Aug-09 17:37

step 263801

-1.667E+01 <x< 3.167E+02

-8.167E+01 <y< 2.517E+02

Factor of Safety 1.48

Max. shear strain-rate

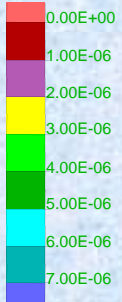

Contour interval= 1.00E-06

Extrap. by averaging

Grid plot



Cable plot

Water Table

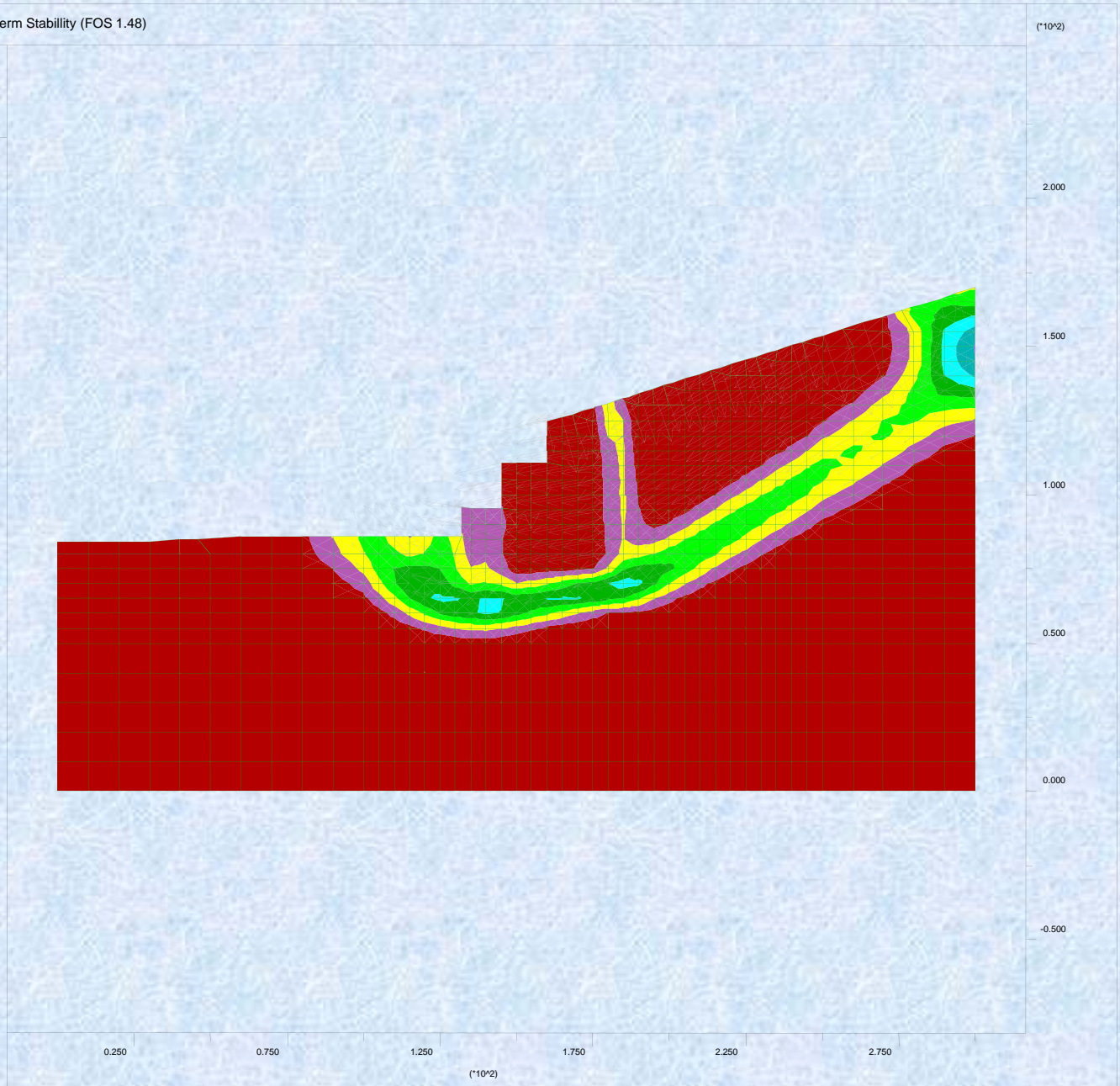

JOB TITLE : Two tier portion of Wall 4

(*10^2)

FLAC (Version 5.00)

LEGEND

29-Sep-09 7:58

step 169044

-1.556E+01 <x< 2.956E+02

-1.056E+02 <y< 2.056E+02

Factor of Safety 1.57

Max. shear strain increment

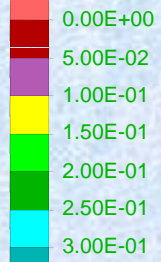

Contour interval= 5.00E-02

Boundary plot



Cable plot

Water Table

Velocity vectors

max vector = 3.595E-05

Terracon Consultants, Inc.

Lenexa, Kansas

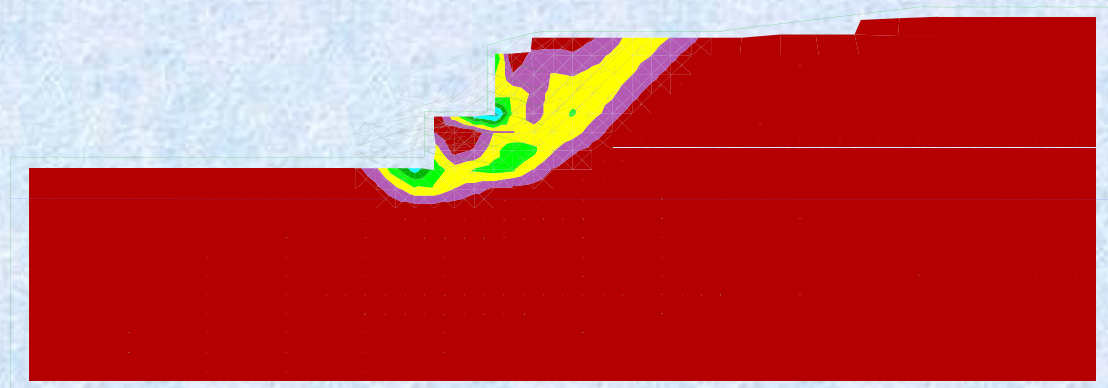

0.250

0.750

1.250

1.750

2.250

2.750

(*10^2)

1.750

1.250

0.750

0.250

-0.250

-0.750

FLAC (Version 6.00)

LEGEND

18-Aug-09 14:04

step 58166

1.197E+02 <x< 2.064E+02

4.413E+01 <y< 1.309E+02

Grid plot

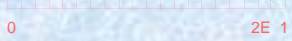

Cable plot

Liner plot

Cable Plot

 Axial Force on

Structure Max. Value

1 (Cable) -1.942E+04

2 (Cable) -1.562E+04

3 (Cable) -1.666E+04

4 (Cable) -1.325E+04

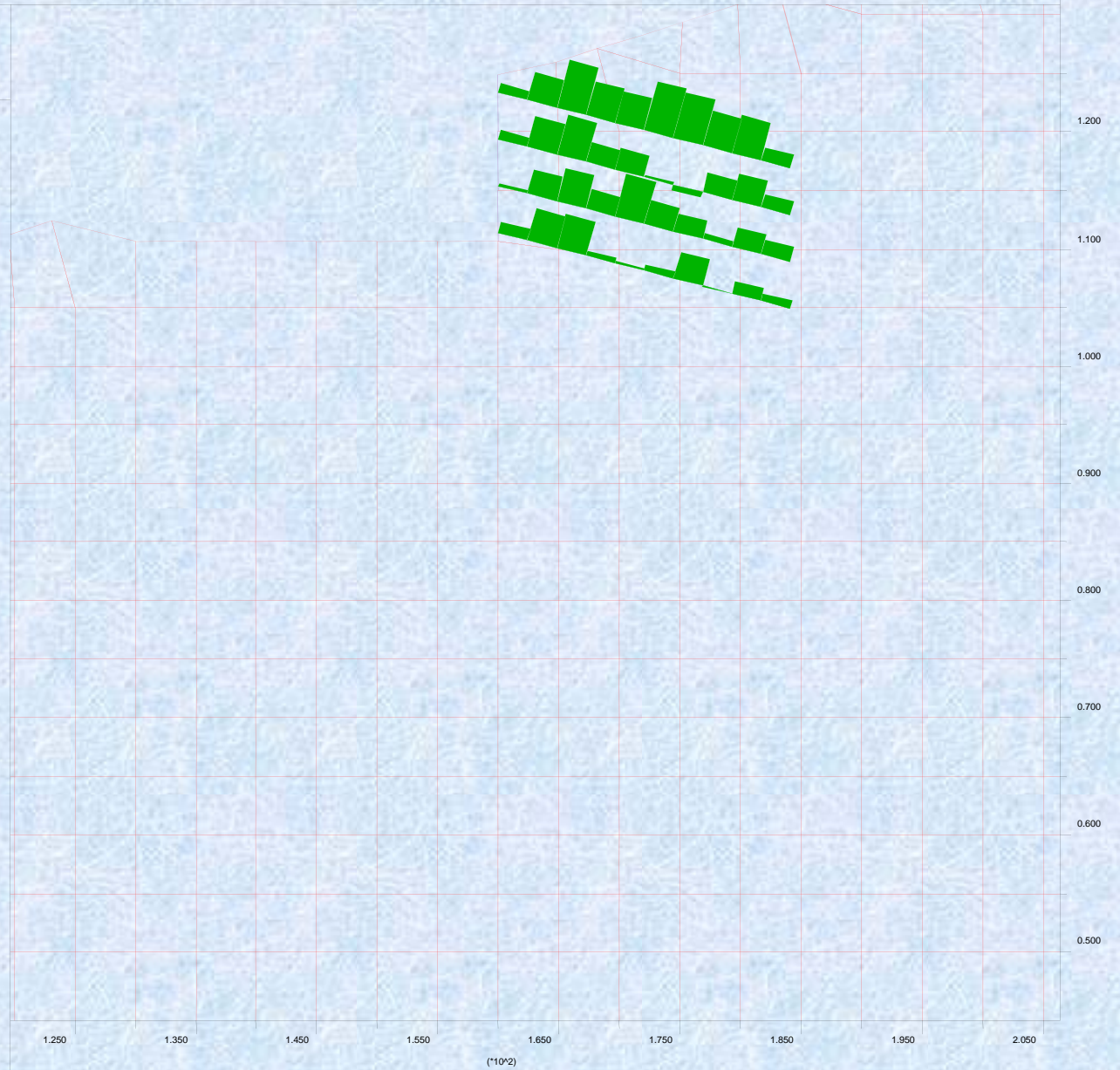

JOB TITLE : Wall-5 (Middle Tier) Cable Load

(*10²)

FLAC (Version 6.00)

LEGEND

18-Aug-09 16:02

step 84239

1.221E+02 <x< 2.040E+02

4.652E+01 <y< 1.285E+02

Grid plot



Cable plot

Liner plot

Cable Plot

■ Axial Force on

Structure Max. Value

1 (Cable) -1.812E+04

2 (Cable) -1.749E+04

3 (Cable) -1.463E+04

4 (Cable) -1.597E+04

6 (Cable) -2.625E+04

7 (Cable) -2.568E+04

8 (Cable) -3.446E+04

9 (Cable) -2.559E+04

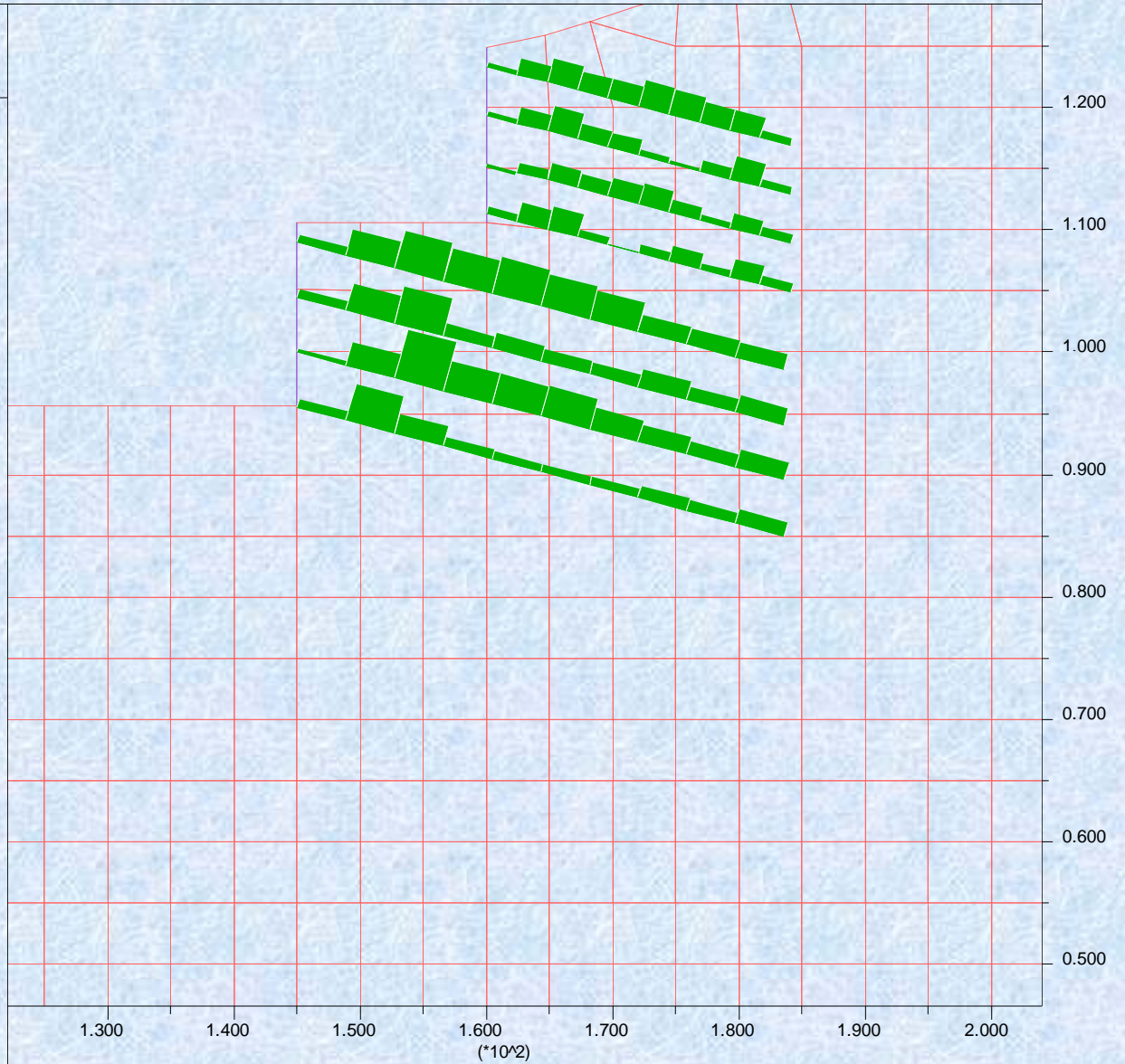

JOB TITLE : Wall-4 (Lower Tier) Cable Load

FLAC (Version 6.00)

LEGEND

18-Aug-09 16:30

step 132215

1.053E+02 <x< 2.208E+02

2.978E+01 <y< 1.452E+02

Grid plot

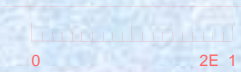

Cable plot

Liner plot

Cable Plot

 Axial Force on

Structure Max. Value

1 (Cable) -1.845E+04

2 (Cable) -1.609E+04

3 (Cable) -1.572E+04

4 (Cable) -1.735E+04

6 (Cable) -2.746E+04

7 (Cable) -2.825E+04

8 (Cable) -3.288E+04

9 (Cable) -2.636E+04

#11 (Cable) -2.663E+04

#12 (Cable) -2.407E+04

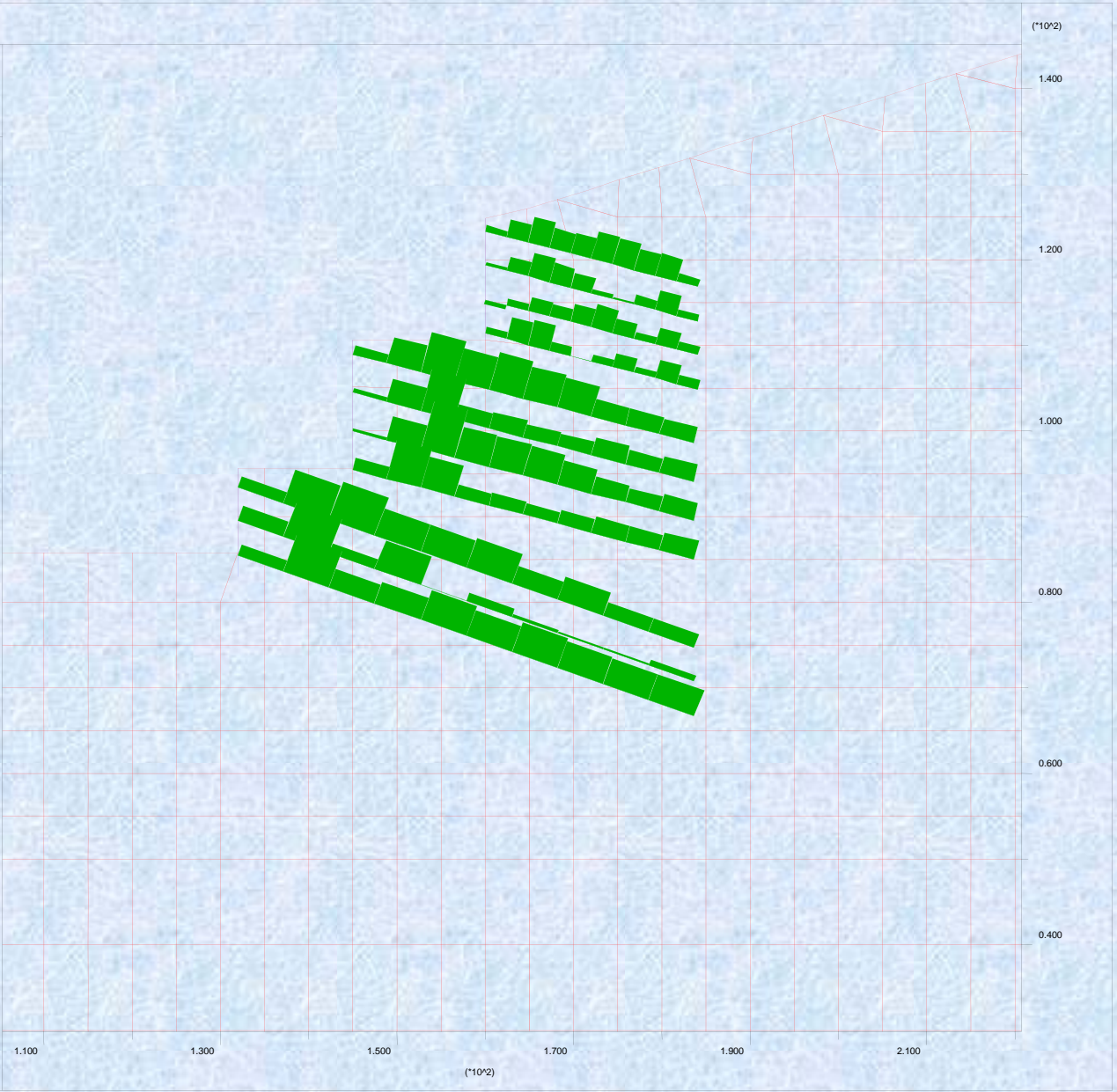

Both FLAC and SNAIL analysis provided similar values of Factor of Safety, and confirmed the following

	Top Tier (Wall 6)	Middle Tier (Wall 5)	Bottom Tier (Wall 4)
Maximum Wall Height (ft) (approximate)	14.3 (with 3H:1V back slope)	15 ft (Wall 6 above it)	9.8 ft (Wall 5 and 6 above it)
Nail Length (ft)	25	40	55
FOS from FLAC	1.76	1.59	1.48
FOS from SNAIL	1.53 (1.49)	1.68 (1.57)	1.60 (1.48)
Design Nail Length (ft)	25	40	55
Design Nail Rows and Nominal Spacing	4 rows vertical 4.75ft horizontal 5ft	3 rows vertical 4.5ft horizontal 5ft	3 rows vertical 4ft horizontal 5ft

Note:

FOS in Parenthesis in with SNAIL = FOS under seismic conditions. All other FOS are under static conditions.







10/07/2009



10/21/2009



11/09/2009



10/09/2009



10/16/2009





11/12/2009



11/16/2009





01/01/2007 12:08 AM















Thanks to
TERRACON
THE JUDY COMPANY
Ne DEPT OF ROADS

